

*Draft Environmental Impact Statement For*

935 Union Avenue  
**935 Union Avenue**

**935 Union Avenue  
Town of New Windsor  
Orange County, New York**

**Prepared by the office of:**

***M.A. Day Engineering, PC***

*3 Van Wyck Lane  
Wappingers Falls, New York 12590  
845-223-3202*

**Prepared for:**

***Banta Hospitality***

*842 Main Street  
Poughkeepsie, New York 12603  
845-474-8235*

# **Volume II**

**June 2018  
Revised March 2019**





# Appendix

## **A. SEQRA Documents**

Long Form Environmental Assessment Form  
Resolution of Positive Declaration  
Adopted Scoping Document

## **B. Reports**

McGoey, Hauser & Edsall Report of Town Landfill – September 2016  
M.A. Day Engineering Stormwater Pollution Prevention Plan April 17, 2018  
AKRF, Inc. Traffic Study  
Ecological Solutions Threatened & Endangered Species Habitat Suitability Report April 14, 2018

## **C. Exhibits**

Exhibit 1 - Existing Site Conditions Survey  
Exhibit 2 - Building Elevations  
Exhibit 3 - Site Plan  
Exhibit 4 - Landscaping Plan  
Exhibit 5 - Lighting Plan  
Exhibit 6 - Orange County Soil Survey – Sheet 31  
Exhibit 7 - Grading, Soil & Erosion Plan  
Exhibit 8 - Section thru Property and Building

## **D. Correspondence**

U.S. Department of the Interior U.S. Fish & Wildlife Service - April 14, 2018  
NYSDEC – May 3, 2018  
Mr. Todd Wiley Email – June 21, 2018

## **E. Consultant's Qualifications**

M.A. Day Engineering Firm Resume  
Marissa Tarallo, PE, PTOE Resume  
Michael Nowicki, B.S. Resume  
Stephen Whalen, R.A. Resume



## A. SEQRA Documents

- Long Form Environmental Assessment Form
- Resolution of Positive Declaration
- Adopted Scoping Document



# Long Form Environmental Assessment Form



**Full Environmental Assessment Form**  
**Part 1 - Project and Setting**

**Instructions for Completing Part 1**

**Part 1 is to be completed by the applicant or project sponsor.** Responses become part of the application for approval or funding, are subject to public review, and may be subject to further verification.

Complete Part 1 based on information currently available. If additional research or investigation would be needed to fully respond to any item, please answer as thoroughly as possible based on current information; indicate whether missing information does not exist, or is not reasonably available to the sponsor; and, when possible, generally describe work or studies which would be necessary to update or fully develop that information.

Applicants/sponsors must complete all items in Sections A & B. In Sections C, D & E, most items contain an initial question that must be answered either "Yes" or "No". If the answer to the initial question is "Yes", complete the sub-questions that follow. If the answer to the initial question is "No", proceed to the next question. Section F allows the project sponsor to identify and attach any additional information. Section G requires the name and signature of the project sponsor to verify that the information contained in Part 1 is accurate and complete.

**A. Project and Sponsor Information.**

Name of Action or Project: 935 UNION AVENUE SITE PLAN		
Project Location (describe, and attach a general location map): 935 UNION AVENUE NEW WINDSOR, NY 12553		
Brief Description of Proposed Action (include purpose or need): THE SITE IS A 2.81 ACRE PARCEL LOCATED AT 935 UNION AVE IN NEW WINDSOR, NY 12553. THE SITE CURRENTLY CONSISTS OF A 2-STORY FRAME AND BRICK BUILDING WHICH WAS FORMERLY OCCUPIED BY STEAK & STEIN. THE SITE IS SERVED BY THE NEW WINDSOR WATER DISTRICT #6 AND SEWER DISTRICT #17. THE PROPOSED ACTION WILL INCLUDE THE DEMOLITION AND REMOVAL OF THE EXISTING BRICK BUILDING THE CONTRUCTION OF A 4 STORY LIMITED SERVICE HOTEL (93 UNITS) WITH REQUISITE PARKING FACILITIES AND LANDSCAPING. THIS WILL INCLUDE A NEW ENTRANCE OFF OF UNION AVENUE (a.k.a. N.Y.S. ROUTE 300).		
Name of Applicant/Sponsor: BANTA HOSPITALITY		Telephone: 914-474-8235
		E-Mail: GBANTA@HOTMAIL.COM
Address: 842 MAIN STREET		
City/PO: POUGHKEEPSIE	State: NY	Zip Code: 12603
Project Contact (if not same as sponsor; give name and title/role): SAME AS SPONSOR		Telephone:
		E-Mail:
Address:		
City/PO:	State:	Zip Code:
Property Owner (if not same as sponsor): SAME AS SPONSOR		Telephone:
		E-Mail:
Address:		
City/PO:	State:	Zip Code:

**B. Government Approvals**

<b>B. Government Approvals, Funding, or Sponsorship.</b> ("Funding" includes grants, loans, tax relief, and any other forms of financial assistance.)		
<b>Government Entity</b>	<b>If Yes: Identify Agency and Approval(s) Required</b>	<b>Application Date (Actual or projected)</b>
a. City Council, Town Board, <input type="checkbox"/> Yes <input checked="" type="checkbox"/> No or Village Board of Trustees		
b. City, Town or Village Planning Board or Commission <input checked="" type="checkbox"/> Yes <input type="checkbox"/> No	PLANNING BOARD - SITE PLAN APPROVAL	
c. City Council, Town or Village Zoning Board of Appeals <input type="checkbox"/> Yes <input checked="" type="checkbox"/> No		
d. Other local agencies <input checked="" type="checkbox"/> Yes <input type="checkbox"/> No	BUILDING DEPARTMENT - BUILDING PERMIT	
e. County agencies <input checked="" type="checkbox"/> Yes <input type="checkbox"/> No	HEALTH DEPARTMENT - WATER & SEWER	
f. Regional agencies <input type="checkbox"/> Yes <input checked="" type="checkbox"/> No		
g. State agencies <input checked="" type="checkbox"/> Yes <input type="checkbox"/> No	NYSDEC - SPDES GP-0-15-002 NYSDOT - HIGHWAY WORK PERMIT	
h. Federal agencies <input type="checkbox"/> Yes <input checked="" type="checkbox"/> No		
i. Coastal Resources. <ul style="list-style-type: none"> <li>i. Is the project site within a Coastal Area, or the waterfront area of a Designated Inland Waterway? <input type="checkbox"/> Yes <input checked="" type="checkbox"/> No</li> <li>ii. Is the project site located in a community with an approved Local Waterfront Revitalization Program? <input type="checkbox"/> Yes <input checked="" type="checkbox"/> No</li> <li>iii. Is the project site within a Coastal Erosion Hazard Area? <input type="checkbox"/> Yes <input checked="" type="checkbox"/> No</li> </ul>		

**C. Planning and Zoning**

<b>C.1. Planning and zoning actions.</b>	
Will administrative or legislative adoption, or amendment of a plan, local law, ordinance, rule or regulation be the only approval(s) which must be granted to enable the proposed action to proceed?	<input type="checkbox"/> Yes <input checked="" type="checkbox"/> No
<ul style="list-style-type: none"> <li>• If Yes, complete sections C, F and G.</li> <li>• If No, proceed to question C.2 and complete all remaining sections and questions in Part 1</li> </ul>	
<b>C.2. Adopted land use plans.</b>	
a. Do any municipally- adopted (city, town, village or county) comprehensive land use plan(s) include the site where the proposed action would be located?	<input checked="" type="checkbox"/> Yes <input type="checkbox"/> No
If Yes, does the comprehensive plan include specific recommendations for the site where the proposed action would be located?	<input checked="" type="checkbox"/> Yes <input type="checkbox"/> No
b. Is the site of the proposed action within any local or regional special planning district (for example: Greenway Brownfield Opportunity Area (BOA); designated State or Federal heritage area; watershed management plan; or other?)	<input checked="" type="checkbox"/> Yes <input type="checkbox"/> No
If Yes, identify the plan(s):	
_____ THE SITE IS LOCATED IN THE SENIOR OVERLAY DISTRICT OF THE TOWN OF NEW WINDSOR. _____ _____ _____	
c. Is the proposed action located wholly or partially within an area listed in an adopted municipal open space plan, or an adopted municipal farmland protection plan?	<input type="checkbox"/> Yes <input checked="" type="checkbox"/> No
If Yes, identify the plan(s):	
_____ _____ _____	



**C.3. Zoning**

a. Is the site of the proposed action located in a municipality with an adopted zoning law or ordinance.  Yes  No  
 If Yes, what is the zoning classification(s) including any applicable overlay district?  
THE SITE SITS IN THE HIGHWAY COMMERCIAL DISTRICT, AND IS A PART OF THE SENIOR OVERLAY DISTRICT.

b. Is the use permitted or allowed by a special or conditional use permit?  Yes  No

c. Is a zoning change requested as part of the proposed action?  Yes  No  
 If Yes,  
 i. What is the proposed new zoning for the site? \_\_\_\_\_

**C.4. Existing community services.**

a. In what school district is the project site located? NEWBURGH ENLARGED CITY SCHOOL DISTRICT

b. What police or other public protection forces serve the project site?  
NEW WINDSOR POLICE DEPARTMENT

c. Which fire protection and emergency medical services serve the project site?  
VAILS GATE FIRE DEPARTMENT

d. What parks serve the project site?  
NEW WINDSOR RECREATION DEPARTMENT

**D. Project Details**

**D.1. Proposed and Potential Development**

a. What is the general nature of the proposed action (e.g., residential, industrial, commercial, recreational; if mixed, include all components)?  
HIGHWAY COMMERCIAL

b. a. Total acreage of the site of the proposed action? \_\_\_\_\_ 2.81 acres  
 b. Total acreage to be physically disturbed? \_\_\_\_\_ 2.81 acres  
 c. Total acreage (project site and any contiguous properties) owned or controlled by the applicant or project sponsor? \_\_\_\_\_ 2.81 acres

c. Is the proposed action an expansion of an existing project or use?  Yes  No  
 i. If Yes, what is the approximate percentage of the proposed expansion and identify the units (e.g., acres, miles, housing units, square feet)? % \_\_\_\_\_ Units: \_\_\_\_\_

d. Is the proposed action a subdivision, or does it include a subdivision?  Yes  No  
 If Yes,  
 i. Purpose or type of subdivision? (e.g., residential, industrial, commercial; if mixed, specify types)  
 \_\_\_\_\_  
 ii. Is a cluster/conservation layout proposed?  Yes  No  
 iii. Number of lots proposed? \_\_\_\_\_  
 iv. Minimum and maximum proposed lot sizes? Minimum \_\_\_\_\_ Maximum \_\_\_\_\_

e. Will proposed action be constructed in multiple phases?  Yes  No  
 i. If No, anticipated period of construction: \_\_\_\_\_ months  
 ii. If Yes:  
 • Total number of phases anticipated \_\_\_\_\_  
 • Anticipated commencement date of phase 1 (including demolition) \_\_\_\_\_ month \_\_\_\_\_ year  
 • Anticipated completion date of final phase \_\_\_\_\_ month \_\_\_\_\_ year  
 • Generally describe connections or relationships among phases, including any contingencies where progress of one phase may determine timing or duration of future phases: \_\_\_\_\_  
 \_\_\_\_\_  
 \_\_\_\_\_

f. Does the project include new residential uses?  Yes  No

If Yes, show numbers of units proposed.

	<u>One Family</u>	<u>Two Family</u>	<u>Three Family</u>	<u>Multiple Family (four or more)</u>
Initial Phase	_____	_____	_____	_____
At completion of all phases	_____	_____	_____	_____

g. Does the proposed action include new non-residential construction (including expansions)?  Yes  No

If Yes,

- i. Total number of structures \_\_\_\_\_ 1
- ii. Dimensions (in feet) of largest proposed structure: 55 FT height; 104.7 FT width; and 214 FT length
- iii. Approximate extent of building space to be heated or cooled: \_\_\_\_\_ 57,350 square feet

h. Does the proposed action include construction or other activities that will result in the impoundment of any liquids, such as creation of a water supply, reservoir, pond, lake, waste lagoon or other storage?  Yes  No

If Yes,

- i. Purpose of the impoundment: \_\_\_\_\_
- ii. If a water impoundment, the principal source of the water:  Ground water  Surface water streams  Other specify: \_\_\_\_\_
- iii. If other than water, identify the type of impounded/contained liquids and their source. \_\_\_\_\_

iv. Approximate size of the proposed impoundment. Volume: \_\_\_\_\_ million gallons; surface area: \_\_\_\_\_ acres

v. Dimensions of the proposed dam or impounding structure: \_\_\_\_\_ height; \_\_\_\_\_ length

vi. Construction method/materials for the proposed dam or impounding structure (e.g., earth fill, rock, wood, concrete): \_\_\_\_\_

## D.2. Project Operations

a. Does the proposed action include any excavation, mining, or dredging, during construction, operations, or both? (Not including general site preparation, grading or installation of utilities or foundations where all excavated materials will remain onsite)  Yes  No

If Yes:

- i. What is the purpose of the excavation or dredging? \_\_\_\_\_
- ii. How much material (including rock, earth, sediments, etc.) is proposed to be removed from the site?
  - Volume (specify tons or cubic yards): \_\_\_\_\_
  - Over what duration of time? \_\_\_\_\_
- iii. Describe nature and characteristics of materials to be excavated or dredged, and plans to use, manage or dispose of them. \_\_\_\_\_

iv. Will there be onsite dewatering or processing of excavated materials?  Yes  No  
If yes, describe. \_\_\_\_\_

v. What is the total area to be dredged or excavated? \_\_\_\_\_ acres

vi. What is the maximum area to be worked at any one time? \_\_\_\_\_ acres

vii. What would be the maximum depth of excavation or dredging? \_\_\_\_\_ feet

viii. Will the excavation require blasting?  Yes  No

ix. Summarize site reclamation goals and plan: \_\_\_\_\_  
\_\_\_\_\_  
\_\_\_\_\_

b. Would the proposed action cause or result in alteration of, increase or decrease in size of, or encroachment into any existing wetland, waterbody, shoreline, beach or adjacent area?  Yes  No

If Yes:

i. Identify the wetland or waterbody which would be affected (by name, water index number, wetland map number or geographic description): \_\_\_\_\_  
\_\_\_\_\_

ii. Describe how the proposed action would affect that waterbody or wetland, e.g. excavation, fill, placement of structures, or alteration of channels, banks and shorelines. Indicate extent of activities, alterations and additions in square feet or acres:

\_\_\_\_\_  
\_\_\_\_\_  
\_\_\_\_\_

iii. Will proposed action cause or result in disturbance to bottom sediments?  Yes  No

If Yes, describe: \_\_\_\_\_

iv. Will proposed action cause or result in the destruction or removal of aquatic vegetation?  Yes  No

If Yes:

- acres of aquatic vegetation proposed to be removed: \_\_\_\_\_
- expected acreage of aquatic vegetation remaining after project completion: \_\_\_\_\_
- purpose of proposed removal (e.g. beach clearing, invasive species control, boat access): \_\_\_\_\_
- proposed method of plant removal: \_\_\_\_\_
- if chemical/herbicide treatment will be used, specify product(s): \_\_\_\_\_

v. Describe any proposed reclamation/mitigation following disturbance: \_\_\_\_\_

c. Will the proposed action use, or create a new demand for water?  Yes  No

If Yes:

i. Total anticipated water usage/demand per day: 10,230 (110/sleeping unit x 93 Unit) gallons/day

ii. Will the proposed action obtain water from an existing public water supply?  Yes  No

If Yes:

- Name of district or service area: NEW WINDSOR WATER DEPARTMENT
- Does the existing public water supply have capacity to serve the proposal?  Yes  No
- Is the project site in the existing district?  Yes  No
- Is expansion of the district needed?  Yes  No
- Do existing lines serve the project site?  Yes  No

iii. Will line extension within an existing district be necessary to supply the project?  Yes  No

If Yes:

- Describe extensions or capacity expansions proposed to serve this project: \_\_\_\_\_
- Source(s) of supply for the district: \_\_\_\_\_

iv. Is a new water supply district or service area proposed to be formed to serve the project site?  Yes  No

If Yes:

- Applicant/sponsor for new district: \_\_\_\_\_
- Date application submitted or anticipated: \_\_\_\_\_
- Proposed source(s) of supply for new district: \_\_\_\_\_

v. If a public water supply will not be used, describe plans to provide water supply for the project: \_\_\_\_\_

vi. If water supply will be from wells (public or private), maximum pumping capacity: \_\_\_\_\_ gallons/minute.

d. Will the proposed action generate liquid wastes?  Yes  No

If Yes:

i. Total anticipated liquid waste generation per day: 10,230 gallons/day

ii. Nature of liquid wastes to be generated (e.g., sanitary wastewater, industrial; if combination, describe all components and approximate volumes or proportions of each): SANITARY WASTE WATER

iii. Will the proposed action use any existing public wastewater treatment facilities?  Yes  No

If Yes:

- Name of wastewater treatment plant to be used: \_\_\_\_\_
- Name of district: NEW WINDSOR SEWER DISTRICT 17
- Does the existing wastewater treatment plant have capacity to serve the project?  Yes  No
- Is the project site in the existing district?  Yes  No
- Is expansion of the district needed?  Yes  No

Yes  No  
 Yes  No

- Do existing sewer lines serve the project site?
- Will line extension within an existing district be necessary to serve the project?

If Yes:

- Describe extensions or capacity expansions proposed to serve this project: \_\_\_\_\_

---

iv. Will a new wastewater (sewage) treatment district be formed to serve the project site?  Yes  No

If Yes:

- Applicant/sponsor for new district: \_\_\_\_\_
- Date application submitted or anticipated: \_\_\_\_\_
- What is the receiving water for the wastewater discharge? \_\_\_\_\_

v. If public facilities will not be used, describe plans to provide wastewater treatment for the project, including specifying proposed receiving water (name and classification if surface discharge, or describe subsurface disposal plans):

\_\_\_\_\_

---

vi. Describe any plans or designs to capture, recycle or reuse liquid waste: \_\_\_\_\_

\_\_\_\_\_

---

e. Will the proposed action disturb more than one acre and create stormwater runoff, either from new point sources (i.e. ditches, pipes, swales, curbs, gutters or other concentrated flows of stormwater) or non-point source (i.e. sheet flow) during construction or post construction?  Yes  No

If Yes:

i. How much impervious surface will the project create in relation to total size of project parcel?

\_\_\_\_\_ Square feet or 1.68 acres (impervious surface)

\_\_\_\_\_ Square feet or 2.81 acres (parcel size)

ii. Describe types of new point sources. STORMWATER

---

iii. Where will the stormwater runoff be directed (i.e. on-site stormwater management facility/structures, adjacent properties, groundwater, on-site surface water or off-site surface waters)?

ON-SITE STORMWATER MANAGEMENT FACILITY/STRUCTURES

- If to surface waters, identify receiving water bodies or wetlands: N/A
- Will stormwater runoff flow to adjacent properties?  Yes  No

iv. Does proposed plan minimize impervious surfaces, use pervious materials or collect and re-use stormwater?  Yes  No

---

f. Does the proposed action include, or will it use on-site, one or more sources of air emissions, including fuel combustion, waste incineration, or other processes or operations?  Yes  No

If Yes, identify:

i. Mobile sources during project operations (e.g., heavy equipment, fleet or delivery vehicles)

\_\_\_\_\_

ii. Stationary sources during construction (e.g., power generation, structural heating, batch plant, crushers)

\_\_\_\_\_

iii. Stationary sources during operations (e.g., process emissions, large boilers, electric generation)

\_\_\_\_\_

---

g. Will any air emission sources named in D.2.f (above), require a NY State Air Registration, Air Facility Permit, or Federal Clean Air Act Title IV or Title V Permit?  Yes  No

If Yes:

i. Is the project site located in an Air quality non-attainment area? (Area routinely or periodically fails to meet ambient air quality standards for all or some parts of the year)  Yes  No

ii. In addition to emissions as calculated in the application, the project will generate:

- \_\_\_\_\_ Tons/year (short tons) of Carbon Dioxide (CO<sub>2</sub>)
- \_\_\_\_\_ Tons/year (short tons) of Nitrous Oxide (N<sub>2</sub>O)
- \_\_\_\_\_ Tons/year (short tons) of Perfluorocarbons (PFCs)
- \_\_\_\_\_ Tons/year (short tons) of Sulfur Hexafluoride (SF<sub>6</sub>)
- \_\_\_\_\_ Tons/year (short tons) of Carbon Dioxide equivalent of Hydrofluorocarbons (HFCs)
- \_\_\_\_\_ Tons/year (short tons) of Hazardous Air Pollutants (HAPs)

h. Will the proposed action generate or emit methane (including, but not limited to, sewage treatment plants, landfills, composting facilities)?  Yes  No

If Yes:

i. Estimate methane generation in tons/year (metric): \_\_\_\_\_

ii. Describe any methane capture, control or elimination measures included in project design (e.g., combustion to generate heat or electricity, flaring): \_\_\_\_\_

---

i. Will the proposed action result in the release of air pollutants from open-air operations or processes, such as quarry or landfill operations?  Yes  No

If Yes: Describe operations and nature of emissions (e.g., diesel exhaust, rock particulates/dust): \_\_\_\_\_

---

j. Will the proposed action result in a substantial increase in traffic above present levels or generate substantial new demand for transportation facilities or services?  Yes  No

If Yes:

i. When is the peak traffic expected (Check all that apply):  Morning  Evening  Weekend  
 Randomly between hours of \_\_\_\_\_ to \_\_\_\_\_.

ii. For commercial activities only, projected number of semi-trailer truck trips/day: \_\_\_\_\_

iii. Parking spaces: Existing \_\_\_\_\_ Proposed \_\_\_\_\_ Net increase/decrease \_\_\_\_\_

iv. Does the proposed action include any shared use parking?  Yes  No

v. If the proposed action includes any modification of existing roads, creation of new roads or change in existing access, describe: \_\_\_\_\_

---

vi. Are public/private transportation service(s) or facilities available within ½ mile of the proposed site?  Yes  No

vii. Will the proposed action include access to public transportation or accommodations for use of hybrid, electric or other alternative fueled vehicles?  Yes  No

viii. Will the proposed action include plans for pedestrian or bicycle accommodations for connections to existing pedestrian or bicycle routes?  Yes  No

---

k. Will the proposed action (for commercial or industrial projects only) generate new or additional demand for energy?  Yes  No

If Yes:

i. Estimate annual electricity demand during operation of the proposed action: \_\_\_\_\_  
T.B.D.

ii. Anticipated sources/suppliers of electricity for the project (e.g., on-site combustion, on-site renewable, via grid/local utility, or other):  
LOCAL UTILITY COMPANY

iii. Will the proposed action require a new, or an upgrade to, an existing substation?  Yes  No

---

l. Hours of operation. Answer all items which apply.

i. During Construction:		ii. During Operations:	
• Monday - Friday: _____	8:00am - 5:00 pm	• Monday - Friday: _____	24 HRS
• Saturday: _____	N/A	• Saturday: _____	24 HRS
• Sunday: _____	N/A	• Sunday: _____	24 HRS
• Holidays: _____	N/A	• Holidays: _____	24 HRS



m. Will the proposed action produce noise that will exceed existing ambient noise levels during construction, operation, or both?  Yes  No  
 If yes:  
 i. Provide details including sources, time of day and duration:  
 \_\_\_\_\_  
 \_\_\_\_\_

ii. Will proposed action remove existing natural barriers that could act as a noise barrier or screen?  Yes  No  
 Describe: \_\_\_\_\_  
 \_\_\_\_\_

---

n.. Will the proposed action have outdoor lighting?  Yes  No  
 If yes:  
 i. Describe source(s), location(s), height of fixture(s), direction/aim, and proximity to nearest occupied structures:  
 \_\_\_\_\_  
 Details will be provided on Lighting Plan

ii. Will proposed action remove existing natural barriers that could act as a light barrier or screen?  Yes  No  
 Describe: \_\_\_\_\_  
 \_\_\_\_\_

---

o. Does the proposed action have the potential to produce odors for more than one hour per day?  Yes  No  
 If Yes, describe possible sources, potential frequency and duration of odor emissions, and proximity to nearest occupied structures: \_\_\_\_\_  
 \_\_\_\_\_  
 \_\_\_\_\_

---

p. Will the proposed action include any bulk storage of petroleum (combined capacity of over 1,100 gallons) or chemical products 185 gallons in above ground storage or any amount in underground storage?  Yes  No  
 If Yes:  
 i. Product(s) to be stored \_\_\_\_\_  
 ii. Volume(s) \_\_\_\_\_ per unit time \_\_\_\_\_ (e.g., month, year)  
 iii. Generally describe proposed storage facilities: \_\_\_\_\_  
 \_\_\_\_\_

---

q. Will the proposed action (commercial, industrial and recreational projects only) use pesticides (i.e., herbicides, insecticides) during construction or operation?  Yes  No  
 If Yes:  
 i. Describe proposed treatment(s):  
 \_\_\_\_\_  
 \_\_\_\_\_  
 \_\_\_\_\_

ii. Will the proposed action use Integrated Pest Management Practices?  Yes  No

---

r. Will the proposed action (commercial or industrial projects only) involve or require the management or disposal of solid waste (excluding hazardous materials)?  Yes  No  
 If Yes:  
 i. Describe any solid waste(s) to be generated during construction or operation of the facility:  
 • Construction: \_\_\_\_\_ 1.0 tons per \_\_\_\_\_ WEEK (unit of time)  
 • Operation : \_\_\_\_\_ 0.875 tons per \_\_\_\_\_ WEEK (unit of time)  
 ii. Describe any proposals for on-site minimization, recycling or reuse of materials to avoid disposal as solid waste:  
 • Construction: RECYCLING WILL BE UTILIZED WHEN POSSIBLE  
 \_\_\_\_\_  
 • Operation: RECYCLING WILL BE UTILIZED WHEN POSSIBLE  
 \_\_\_\_\_

iii. Proposed disposal methods/facilities for solid waste generated on-site:  
 • Construction: APPROVED CONTRACTOR  
 \_\_\_\_\_  
 • Operation: APPROVED CONTRACTOR  
 \_\_\_\_\_  
 \_\_\_\_\_

s. Does the proposed action include construction or modification of a solid waste management facility?  Yes  No

If Yes:

i. Type of management or handling of waste proposed for the site (e.g., recycling or transfer station, composting, landfill, or other disposal activities): \_\_\_\_\_

ii. Anticipated rate of disposal/processing:

- \_\_\_\_\_ Tons/month, if transfer or other non-combustion/thermal treatment, or
- \_\_\_\_\_ Tons/hour, if combustion or thermal treatment

iii. If landfill, anticipated site life: \_\_\_\_\_ years

---

t. Will proposed action at the site involve the commercial generation, treatment, storage, or disposal of hazardous waste?  Yes  No

If Yes:

i. Name(s) of all hazardous wastes or constituents to be generated, handled or managed at facility: \_\_\_\_\_

ii. Generally describe processes or activities involving hazardous wastes or constituents: \_\_\_\_\_

iii. Specify amount to be handled or generated \_\_\_\_\_ tons/month

iv. Describe any proposals for on-site minimization, recycling or reuse of hazardous constituents: \_\_\_\_\_

v. Will any hazardous wastes be disposed at an existing offsite hazardous waste facility?  Yes  No

If Yes: provide name and location of facility: \_\_\_\_\_

If No: describe proposed management of any hazardous wastes which will not be sent to a hazardous waste facility: \_\_\_\_\_

**E. Site and Setting of Proposed Action**

**E.1. Land uses on and surrounding the project site**

a. Existing land uses.

- i. Check all uses that occur on, adjoining and near the project site.
- Urban  Industrial  Commercial  Residential (suburban)  Rural (non-farm)
- Forest  Agriculture  Aquatic  Other (specify): \_\_\_\_\_

ii. If mix of uses, generally describe: \_\_\_\_\_

b. Land uses and covertypes on the project site.

Land use or Covertypes	Current Acreage	Acreage After Project Completion	Change (Acres +/-)
• Roads, buildings, and other paved or impervious surfaces	1.46	1.68	+0.22
• Forested	0.98	0	-0.98
• Meadows, grasslands or brushlands (non-agricultural, including abandoned agricultural)	0	0	0
• Agricultural (includes active orchards, field, greenhouse etc.)	0	0	0
• Surface water features (lakes, ponds, streams, rivers, etc.)	0	0	0
• Wetlands (freshwater or tidal)	0	0	0
• Non-vegetated (bare rock, earth or fill)	0	0	0
• Other Describe: <u>LAWN/LANDSCAPED AREA</u>	0.37	1.13	+0.76

c. Is the project site presently used by members of the community for public recreation?  Yes  No  
 i. If Yes: explain: \_\_\_\_\_

---

d. Are there any facilities serving children, the elderly, people with disabilities (e.g., schools, hospitals, licensed day care centers, or group homes) within 1500 feet of the project site?  Yes  No  
 If Yes,  
 i. Identify Facilities: \_\_\_\_\_  
 \_\_\_\_\_

---

e. Does the project site contain an existing dam?  Yes  No  
 If Yes:  
 i. Dimensions of the dam and impoundment:  
 • Dam height: \_\_\_\_\_ feet  
 • Dam length: \_\_\_\_\_ feet  
 • Surface area: \_\_\_\_\_ acres  
 • Volume impounded: \_\_\_\_\_ gallons OR acre-feet  
 ii. Dam's existing hazard classification: \_\_\_\_\_  
 iii. Provide date and summarize results of last inspection: \_\_\_\_\_  
 \_\_\_\_\_

---

f. Has the project site ever been used as a municipal, commercial or industrial solid waste management facility, or does the project site adjoin property which is now, or was at one time, used as a solid waste management facility?  Yes  No  
 If Yes:  
 i. Has the facility been formally closed?  Yes  No  
 • If yes, cite sources/documentation: \_\_\_\_\_  
 ii. Describe the location of the project site relative to the boundaries of the solid waste management facility: \_\_\_\_\_  
 \_\_\_\_\_  
 iii. Describe any development constraints due to the prior solid waste activities: \_\_\_\_\_  
 \_\_\_\_\_

---

g. Have hazardous wastes been generated, treated and/or disposed of at the site, or does the project site adjoin property which is now or was at one time used to commercially treat, store and/or dispose of hazardous waste?  Yes  No  
 If Yes:  
 i. Describe waste(s) handled and waste management activities, including approximate time when activities occurred: \_\_\_\_\_  
 \_\_\_\_\_

---

h. Potential contamination history. Has there been a reported spill at the proposed project site, or have any remedial actions been conducted at or adjacent to the proposed site?  Yes  No  
 If Yes:  
 i. Is any portion of the site listed on the NYSDEC Spills Incidents database or Environmental Site Remediation database? Check all that apply:  Yes  No  
 Yes – Spills Incidents database Provide DEC ID number(s): \_\_\_\_\_  
 Yes – Environmental Site Remediation database Provide DEC ID number(s): \_\_\_\_\_  
 Neither database  
 ii. If site has been subject of RCRA corrective activities, describe control measures: \_\_\_\_\_  
 \_\_\_\_\_  
 iii. Is the project within 2000 feet of any site in the NYSDEC Environmental Site Remediation database?  Yes  No  
 If yes, provide DEC ID number(s): 336019  
 iv. If yes to (i), (ii) or (iii) above, describe current status of site(s):  
 UNKNOWN  
 \_\_\_\_\_



v. Is the project site subject to an institutional control limiting property uses?  Yes  No

- If yes, DEC site ID number: \_\_\_\_\_
- Describe the type of institutional control (e.g., deed restriction or easement): \_\_\_\_\_
- Describe any use limitations: \_\_\_\_\_
- Describe any engineering controls: \_\_\_\_\_
- Will the project affect the institutional or engineering controls in place?  Yes  No
- Explain: \_\_\_\_\_  
 \_\_\_\_\_  
 \_\_\_\_\_

**E.2. Natural Resources On or Near Project Site**

a. What is the average depth to bedrock on the project site? \_\_\_\_\_ >5 feet

b. Are there bedrock outcroppings on the project site?  Yes  No  
 If Yes, what proportion of the site is comprised of bedrock outcroppings? \_\_\_\_\_ %

c. Predominant soil type(s) present on project site:

Mardin gravelly silt loam	_____	60 %
Quarries	_____	40 %
_____	_____	_____ %

d. What is the average depth to the water table on the project site? Average: \_\_\_\_\_ feet

e. Drainage status of project site soils:  Well Drained: \_\_\_\_\_ % of site  
 Moderately Well Drained: 100 % of site  
 Poorly Drained \_\_\_\_\_ % of site

f. Approximate proportion of proposed action site with slopes:  0-10%: 80 % of site  
 10-15%: 5 % of site  
 15% or greater: 15 % of site

g. Are there any unique geologic features on the project site?  Yes  No  
 If Yes, describe: \_\_\_\_\_  
 \_\_\_\_\_

h. Surface water features.

i. Does any portion of the project site contain wetlands or other waterbodies (including streams, rivers, ponds or lakes)?  Yes  No

ii. Do any wetlands or other waterbodies adjoin the project site?  Yes  No

If Yes to either *i* or *ii*, continue. If No, skip to E.2.i.

iii. Are any of the wetlands or waterbodies within or adjoining the project site regulated by any federal, state or local agency?  Yes  No

iv. For each identified regulated wetland and waterbody on the project site, provide the following information:

- Streams: Name N/A Classification N/A
- Lakes or Ponds: Name LAKE WASHINGTON Classification RESERVOIR
- Wetlands: Name N/A Approximate Size \_\_\_\_\_
- Wetland No. (if regulated by DEC) N/A

v. Are any of the above water bodies listed in the most recent compilation of NYS water quality-impaired waterbodies?  Yes  No  
 If yes, name of impaired water body/bodies and basis for listing as impaired: \_\_\_\_\_  
 \_\_\_\_\_

i. Is the project site in a designated Floodway?  Yes  No

j. Is the project site in the 100 year Floodplain?  Yes  No

k. Is the project site in the 500 year Floodplain?  Yes  No

l. Is the project site located over, or immediately adjoining, a primary, principal or sole source aquifer?  Yes  No  
 If Yes:  
 i. Name of aquifer: \_\_\_\_\_

m. Identify the predominant wildlife species that occupy or use the project site: N/A _____ _____ _____	_____ _____ _____
n. Does the project site contain a designated significant natural community? <span style="float: right;"><input type="checkbox"/> Yes <input checked="" type="checkbox"/> No</span> If Yes:	
i. Describe the habitat/community (composition, function, and basis for designation): _____ _____	
ii. Source(s) of description or evaluation: _____	
iii. Extent of community/habitat:	
<ul style="list-style-type: none"> <li>• Currently: _____ acres</li> <li>• Following completion of project as proposed: _____ acres</li> <li>• Gain or loss (indicate + or -): _____ acres</li> </ul>	
o. Does project site contain any species of plant or animal that is listed by the federal government or NYS as endangered or threatened, or does it contain any areas identified as habitat for an endangered or threatened species? <span style="float: right;"><input checked="" type="checkbox"/> Yes <input type="checkbox"/> No</span>	
THE SITE IS LOCATED WITHIN AN AREA THAT HAS BEEN IDENTIFIED BY THE NYS DEPARTMENT OF ENVIRONMENTAL CONSERVATION AS A GENERALIZED LOCATION OF ANIMALS AND PLANTS THAT ARE ENDANGERED IN NEW YORK STATE. HOWEVER THE SITE HAS BEEN PREVIOUSLY DEVELOPED AND IS UNLIKELY TO CONTAIN A HABITAT FOR ENDANGERED OR THREATENED SPECIES.	
p. Does the project site contain any species of plant or animal that is listed by NYS as rare, or as a species of special concern? <span style="float: right;"><input type="checkbox"/> Yes <input checked="" type="checkbox"/> No</span>	
q. Is the project site or adjoining area currently used for hunting, trapping, fishing or shell fishing? <span style="float: right;"><input type="checkbox"/> Yes <input checked="" type="checkbox"/> No</span> If yes, give a brief description of how the proposed action may affect that use: _____ _____	
<b>E.3. Designated Public Resources On or Near Project Site</b>	
a. Is the project site, or any portion of it, located in a designated agricultural district certified pursuant to Agriculture and Markets Law, Article 25-AA, Section 303 and 304? <span style="float: right;"><input type="checkbox"/> Yes <input checked="" type="checkbox"/> No</span> If Yes, provide county plus district name/number: _____	
b. Are agricultural lands consisting of highly productive soils present? <span style="float: right;"><input type="checkbox"/> Yes <input checked="" type="checkbox"/> No</span> i. If Yes: acreage(s) on project site? _____ ii. Source(s) of soil rating(s): _____	
c. Does the project site contain all or part of, or is it substantially contiguous to, a registered National Natural Landmark? <span style="float: right;"><input type="checkbox"/> Yes <input checked="" type="checkbox"/> No</span> If Yes:	
i. Nature of the natural landmark: <input type="checkbox"/> Biological Community <input type="checkbox"/> Geological Feature ii. Provide brief description of landmark, including values behind designation and approximate size/extent: _____ _____ _____	
d. Is the project site located in or does it adjoin a state listed Critical Environmental Area? <span style="float: right;"><input type="checkbox"/> Yes <input checked="" type="checkbox"/> No</span> If Yes:	
i. CEA name: _____ ii. Basis for designation: _____ iii. Designating agency and date: _____	

e. Does the project site contain, or is it substantially contiguous to, a building, archaeological site, or district which is listed on, or has been nominated by the NYS Board of Historic Preservation for inclusion on, the State or National Register of Historic Places?	<input type="checkbox"/> Yes <input checked="" type="checkbox"/> No
If Yes:	
<i>i.</i> Nature of historic/archaeological resource: <input type="checkbox"/> Archaeological Site <input type="checkbox"/> Historic Building or District	
<i>ii.</i> Name: _____	
<i>iii.</i> Brief description of attributes on which listing is based: _____	
f. Is the project site, or any portion of it, located in or adjacent to an area designated as sensitive for archaeological sites on the NY State Historic Preservation Office (SHPO) archaeological site inventory?	<input type="checkbox"/> Yes <input checked="" type="checkbox"/> No
g. Have additional archaeological or historic site(s) or resources been identified on the project site?	
If Yes:	
<i>i.</i> Describe possible resource(s): _____	
<i>ii.</i> Basis for identification: _____	
h. Is the project site within five miles of any officially designated and publicly accessible federal, state, or local scenic or aesthetic resource?	<input type="checkbox"/> Yes <input checked="" type="checkbox"/> No
If Yes:	
<i>i.</i> Identify resource: _____	
<i>ii.</i> Nature of, or basis for, designation (e.g., established highway overlook, state or local park, state historic trail or scenic byway, etc.): _____	
<i>iii.</i> Distance between project and resource: _____ miles.	
i. Is the project site located within a designated river corridor under the Wild, Scenic and Recreational Rivers Program 6 NYCRR 666?	<input type="checkbox"/> Yes <input checked="" type="checkbox"/> No
If Yes:	
<i>i.</i> Identify the name of the river and its designation: _____	
<i>ii.</i> Is the activity consistent with development restrictions contained in 6NYCRR Part 666?	
<input type="checkbox"/> Yes <input type="checkbox"/> No	

**F. Additional Information**

Attach any additional information which may be needed to clarify your project.

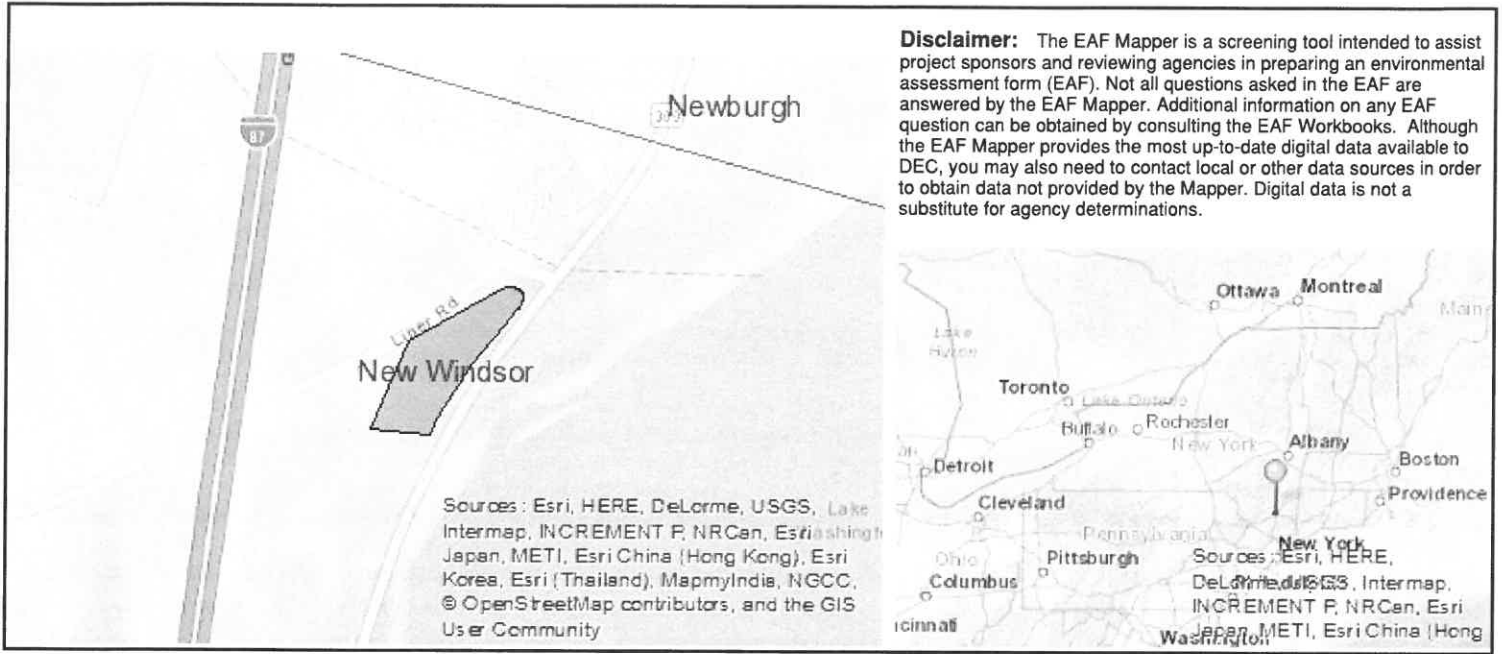
If you have identified any adverse impacts which could be associated with your proposal, please describe those impacts plus any measures which you propose to avoid or minimize them.

**G. Verification**

I certify that the information provided is true to the best of my knowledge.

Applicant/Sponsor Name \_\_\_\_\_ Date \_\_\_\_\_

Signature  \_\_\_\_\_ Title \_\_\_\_\_



B.i.i [Coastal or Waterfront Area]	No
B.i.ii [Local Waterfront Revitalization Area]	No
C.2.b. [Special Planning District]	Digital mapping data are not available or are incomplete. Refer to EAF Workbook.
E.1.h [DEC Spills or Remediation Site - Potential Contamination History]	Digital mapping data are not available or are incomplete. Refer to EAF Workbook.
E.1.h.i [DEC Spills or Remediation Site - Listed]	Digital mapping data are not available or are incomplete. Refer to EAF Workbook.
E.1.h.i [DEC Spills or Remediation Site - Environmental Site Remediation Database]	Digital mapping data are not available or are incomplete. Refer to EAF Workbook.
E.1.h.iii [Within 2,000' of DEC Remediation Site]	Yes
E.1.h.iii [Within 2,000' of DEC Remediation Site - DEC ID]	336019
E.2.g [Unique Geologic Features]	No
E.2.h.i [Surface Water Features]	No
E.2.h.ii [Surface Water Features]	Yes
E.2.h.iii [Surface Water Features]	Yes - Digital mapping information on local and federal wetlands and waterbodies is known to be incomplete. Refer to EAF Workbook.
E.2.h.v [Impaired Water Bodies]	No
E.2.i. [Floodway]	No
E.2.j. [100 Year Floodplain]	No
E.2.k. [500 Year Floodplain]	No
E.2.l. [Aquifers]	No
E.2.n. [Natural Communities]	No
E.2.o. [Endangered or Threatened Species]	Yes

E.2.p. [Rare Plants or Animals]	No
E.3.a. [Agricultural District]	No
E.3.c. [National Natural Landmark]	No
E.3.d [Critical Environmental Area]	No
E.3.e. [National Register of Historic Places]	Digital mapping data are not available or are incomplete. Refer to EAF Workbook.
E.3.f. [Archeological Sites]	No
E.3.i. [Designated River Corridor]	No

**Full Environmental Assessment Form**  
**Part 2 - Identification of Potential Project Impacts**

Agency Use Only [If applicable]

Project :   
 Date :

**Part 2 is to be completed by the lead agency.** Part 2 is designed to help the lead agency inventory all potential resources that could be affected by a proposed project or action. We recognize that the lead agency's reviewer(s) will not necessarily be environmental professionals. So, the questions are designed to walk a reviewer through the assessment process by providing a series of questions that can be answered using the information found in Part 1. To further assist the lead agency in completing Part 2, the form identifies the most relevant questions in Part 1 that will provide the information needed to answer the Part 2 question. When Part 2 is completed, the lead agency will have identified the relevant environmental areas that may be impacted by the proposed activity.

If the lead agency is a state agency **and** the action is in any Coastal Area, complete the Coastal Assessment Form before proceeding with this assessment.

**Tips for completing Part 2:**

- Review all of the information provided in Part 1.
- Review any application, maps, supporting materials and the Full EAF Workbook.
- Answer each of the 18 questions in Part 2.
- If you answer “Yes” to a numbered question, please complete all the questions that follow in that section.
- If you answer “No” to a numbered question, move on to the next numbered question.
- Check appropriate column to indicate the anticipated size of the impact.
- Proposed projects that would exceed a numeric threshold contained in a question should result in the reviewing agency checking the box “Moderate to large impact may occur.”
- The reviewer is not expected to be an expert in environmental analysis.
- If you are not sure or undecided about the size of an impact, it may help to review the sub-questions for the general question and consult the workbook.
- When answering a question consider all components of the proposed activity, that is, the “whole action”.
- Consider the possibility for long-term and cumulative impacts as well as direct impacts.
- Answer the question in a reasonable manner considering the scale and context of the project.

<b>1. Impact on Land</b> Proposed action may involve construction on, or physical alteration of, the land surface of the proposed site. (See Part 1. D.1) <i>If “Yes”, answer questions a - j. If “No”, move on to Section 2.</i>			
		<input type="checkbox"/> NO	<input checked="" type="checkbox"/> YES
	Relevant Part I Question(s)	No, or small impact may occur	Moderate to large impact may occur
a. The proposed action may involve construction on land where depth to water table is less than 3 feet.	E2d	<input checked="" type="checkbox"/>	<input type="checkbox"/>
b. The proposed action may involve construction on slopes of 15% or greater.	E2f	<input checked="" type="checkbox"/>	<input type="checkbox"/>
c. The proposed action may involve construction on land where bedrock is exposed, or generally within 5 feet of existing ground surface.	E2a	<input checked="" type="checkbox"/>	<input type="checkbox"/>
d. The proposed action may involve the excavation and removal of more than 1,000 tons of natural material.	D2a	<input checked="" type="checkbox"/>	<input type="checkbox"/>
e. The proposed action may involve construction that continues for more than one year or in multiple phases.	D1e	<input checked="" type="checkbox"/>	<input type="checkbox"/>
f. The proposed action may result in increased erosion, whether from physical disturbance or vegetation removal (including from treatment by herbicides).	D2e, D2q	<input checked="" type="checkbox"/>	<input type="checkbox"/>
g. The proposed action is, or may be, located within a Coastal Erosion hazard area.	B1i	<input checked="" type="checkbox"/>	<input type="checkbox"/>
h. Other impacts: <u>N/A</u>		<input type="checkbox"/>	<input type="checkbox"/>



**2. Impact on Geological Features**

The proposed action may result in the modification or destruction of, or inhibit access to, any unique or unusual land forms on the site (e.g., cliffs, dunes, minerals, fossils, caves). (See Part 1. E.2.g)

NO

YES

*If "Yes", answer questions a - c. If "No", move on to Section 3.*

	Relevant Part I Question(s)	No, or small impact may occur	Moderate to large impact may occur
a. Identify the specific land form(s) attached: _____ _____	E2g	<input type="checkbox"/>	<input type="checkbox"/>
b. The proposed action may affect or is adjacent to a geological feature listed as a registered National Natural Landmark. Specific feature: _____	E3c	<input type="checkbox"/>	<input type="checkbox"/>
c. Other impacts: _____ _____		<input type="checkbox"/>	<input type="checkbox"/>

**3. Impacts on Surface Water**

The proposed action may affect one or more wetlands or other surface water bodies (e.g., streams, rivers, ponds or lakes). (See Part 1. D.2, E.2.h)

NO

YES

*If "Yes", answer questions a - l. If "No", move on to Section 4.*

	Relevant Part I Question(s)	No, or small impact may occur	Moderate to large impact may occur
a. The proposed action may create a new water body.	D2b, D1h	<input type="checkbox"/>	<input type="checkbox"/>
b. The proposed action may result in an increase or decrease of over 10% or more than a 10 acre increase or decrease in the surface area of any body of water.	D2b	<input type="checkbox"/>	<input type="checkbox"/>
c. The proposed action may involve dredging more than 100 cubic yards of material from a wetland or water body.	D2a	<input type="checkbox"/>	<input type="checkbox"/>
d. The proposed action may involve construction within or adjoining a freshwater or tidal wetland, or in the bed or banks of any other water body.	E2h	<input type="checkbox"/>	<input type="checkbox"/>
e. The proposed action may create turbidity in a waterbody, either from upland erosion, runoff or by disturbing bottom sediments.	D2a, D2h	<input type="checkbox"/>	<input type="checkbox"/>
f. The proposed action may include construction of one or more intake(s) for withdrawal of water from surface water.	D2c	<input type="checkbox"/>	<input type="checkbox"/>
g. The proposed action may include construction of one or more outfall(s) for discharge of wastewater to surface water(s).	D2d	<input type="checkbox"/>	<input type="checkbox"/>
h. The proposed action may cause soil erosion, or otherwise create a source of stormwater discharge that may lead to siltation or other degradation of receiving water bodies.	D2e	<input type="checkbox"/>	<input type="checkbox"/>
i. The proposed action may affect the water quality of any water bodies within or downstream of the site of the proposed action.	E2h	<input type="checkbox"/>	<input type="checkbox"/>
j. The proposed action may involve the application of pesticides or herbicides in or around any water body.	D2q, E2h	<input type="checkbox"/>	<input type="checkbox"/>
k. The proposed action may require the construction of new, or expansion of existing, wastewater treatment facilities.	D1a, D2d	<input type="checkbox"/>	<input type="checkbox"/>

I. Other impacts: _____ _____		<input type="checkbox"/>	<input type="checkbox"/>
----------------------------------	--	--------------------------	--------------------------

**4. Impact on groundwater**  
 The proposed action may result in new or additional use of ground water, or may have the potential to introduce contaminants to ground water or an aquifer.  NO  YES  
 (See Part 1. D.2.a, D.2.c, D.2.d, D.2.p, D.2.q, D.2.t)  
 If "Yes", answer questions a - h. If "No", move on to Section 5.

	Relevant Part I Question(s)	No, or small impact may occur	Moderate to large impact may occur
a. The proposed action may require new water supply wells, or create additional demand on supplies from existing water supply wells.	D2c	<input type="checkbox"/>	<input type="checkbox"/>
b. Water supply demand from the proposed action may exceed safe and sustainable withdrawal capacity rate of the local supply or aquifer. Cite Source: _____	D2c	<input type="checkbox"/>	<input type="checkbox"/>
c. The proposed action may allow or result in residential uses in areas without water and sewer services.	D1a, D2c	<input type="checkbox"/>	<input type="checkbox"/>
d. The proposed action may include or require wastewater discharged to groundwater.	D2d, E2l	<input type="checkbox"/>	<input type="checkbox"/>
e. The proposed action may result in the construction of water supply wells in locations where groundwater is, or is suspected to be, contaminated.	D2c, E1f, E1g, E1h	<input type="checkbox"/>	<input type="checkbox"/>
f. The proposed action may require the bulk storage of petroleum or chemical products over ground water or an aquifer.	D2p, E2l	<input type="checkbox"/>	<input type="checkbox"/>
g. The proposed action may involve the commercial application of pesticides within 100 feet of potable drinking water or irrigation sources.	E2h, D2q, E2l, D2c	<input type="checkbox"/>	<input type="checkbox"/>
h. Other impacts: _____ _____		<input type="checkbox"/>	<input type="checkbox"/>

**5. Impact on Flooding**  
 The proposed action may result in development on lands subject to flooding.  NO  YES  
 (See Part 1. E.2)  
 If "Yes", answer questions a - g. If "No", move on to Section 6.

	Relevant Part I Question(s)	No, or small impact may occur	Moderate to large impact may occur
a. The proposed action may result in development in a designated floodway.	E2i	<input type="checkbox"/>	<input type="checkbox"/>
b. The proposed action may result in development within a 100 year floodplain.	E2j	<input type="checkbox"/>	<input type="checkbox"/>
c. The proposed action may result in development within a 500 year floodplain.	E2k	<input type="checkbox"/>	<input type="checkbox"/>
d. The proposed action may result in, or require, modification of existing drainage patterns.	D2b, D2e	<input type="checkbox"/>	<input type="checkbox"/>
e. The proposed action may change flood water flows that contribute to flooding.	D2b, E2i, E2j, E2k	<input type="checkbox"/>	<input type="checkbox"/>
f. If there is a dam located on the site of the proposed action, is the dam in need of repair, or upgrade?	E1e	<input type="checkbox"/>	<input type="checkbox"/>



g. Other impacts: _____ _____		<input type="checkbox"/>	<input type="checkbox"/>
----------------------------------	--	--------------------------	--------------------------

**6. Impacts on Air**  
 The proposed action may include a state regulated air emission source.  NO  YES  
 (See Part 1. D.2.f., D.2.h, D.2.g)  
 If "Yes", answer questions a - f. If "No", move on to Section 7.

	Relevant Part I Question(s)	No, or small impact may occur	Moderate to large impact may occur
a. If the proposed action requires federal or state air emission permits, the action may also emit one or more greenhouse gases at or above the following levels: i. More than 1000 tons/year of carbon dioxide (CO <sub>2</sub> ) ii. More than 3.5 tons/year of nitrous oxide (N <sub>2</sub> O) iii. More than 1000 tons/year of carbon equivalent of perfluorocarbons (PFCs) iv. More than .045 tons/year of sulfur hexafluoride (SF <sub>6</sub> ) v. More than 1000 tons/year of carbon dioxide equivalent of hydrochloroflouorocarbons (HFCs) emissions vi. 43 tons/year or more of methane	D2g D2g D2g D2g D2g D2h	<input type="checkbox"/> <input type="checkbox"/> <input type="checkbox"/> <input type="checkbox"/> <input type="checkbox"/> <input type="checkbox"/>	<input type="checkbox"/> <input type="checkbox"/> <input type="checkbox"/> <input type="checkbox"/> <input type="checkbox"/> <input type="checkbox"/>
b. The proposed action may generate 10 tons/year or more of any one designated hazardous air pollutant, or 25 tons/year or more of any combination of such hazardous air pollutants.	D2g	<input type="checkbox"/>	<input type="checkbox"/>
c. The proposed action may require a state air registration, or may produce an emissions rate of total contaminants that may exceed 5 lbs. per hour, or may include a heat source capable of producing more than 10 million BTU's per hour.	D2f, D2g	<input type="checkbox"/>	<input type="checkbox"/>
d. The proposed action may reach 50% of any of the thresholds in "a" through "c", above.	D2g	<input type="checkbox"/>	<input type="checkbox"/>
e. The proposed action may result in the combustion or thermal treatment of more than 1 ton of refuse per hour.	D2s	<input type="checkbox"/>	<input type="checkbox"/>
f. Other impacts: _____ _____		<input type="checkbox"/>	<input type="checkbox"/>

**7. Impact on Plants and Animals**  
 The proposed action may result in a loss of flora or fauna. (See Part 1. E.2. m.-q.)  NO  YES  
 If "Yes", answer questions a - j. If "No", move on to Section 8.

	Relevant Part I Question(s)	No, or small impact may occur	Moderate to large impact may occur
a. The proposed action may cause reduction in population or loss of individuals of any threatened or endangered species, as listed by New York State or the Federal government, that use the site, or are found on, over, or near the site.	E2o	<input type="checkbox"/>	<input type="checkbox"/>
b. The proposed action may result in a reduction or degradation of any habitat used by any rare, threatened or endangered species, as listed by New York State or the federal government.	E2o	<input type="checkbox"/>	<input type="checkbox"/>
c. The proposed action may cause reduction in population, or loss of individuals, of any species of special concern or conservation need, as listed by New York State or the Federal government, that use the site, or are found on, over, or near the site.	E2p	<input type="checkbox"/>	<input type="checkbox"/>
d. The proposed action may result in a reduction or degradation of any habitat used by any species of special concern and conservation need, as listed by New York State or the Federal government.	E2p	<input type="checkbox"/>	<input type="checkbox"/>

e. The proposed action may diminish the capacity of a registered National Natural Landmark to support the biological community it was established to protect.	E3c	<input type="checkbox"/>	<input type="checkbox"/>
f. The proposed action may result in the removal of, or ground disturbance in, any portion of a designated significant natural community. Source: _____	E2n	<input type="checkbox"/>	<input type="checkbox"/>
g. The proposed action may substantially interfere with nesting/breeding, foraging, or over-wintering habitat for the predominant species that occupy or use the project site.	E2m	<input type="checkbox"/>	<input type="checkbox"/>
h. The proposed action requires the conversion of more than 10 acres of forest, grassland or any other regionally or locally important habitat. Habitat type & information source: _____	E1b	<input type="checkbox"/>	<input type="checkbox"/>
i. Proposed action (commercial, industrial or recreational projects, only) involves use of herbicides or pesticides.	D2q	<input type="checkbox"/>	<input type="checkbox"/>
j. Other impacts: _____		<input type="checkbox"/>	<input type="checkbox"/>

<b>8. Impact on Agricultural Resources</b>			
The proposed action may impact agricultural resources. (See Part 1. E.3.a. and b.)		<input checked="" type="checkbox"/> NO	<input type="checkbox"/> YES
<i>If "Yes", answer questions a - h. If "No", move on to Section 9.</i>			
	<b>Relevant Part I Question(s)</b>	<b>No, or small impact may occur</b>	<b>Moderate to large impact may occur</b>
a. The proposed action may impact soil classified within soil group 1 through 4 of the NYS Land Classification System.	E2c, E3b	<input type="checkbox"/>	<input type="checkbox"/>
b. The proposed action may sever, cross or otherwise limit access to agricultural land (includes cropland, hayfields, pasture, vineyard, orchard, etc).	E1a, E1b	<input type="checkbox"/>	<input type="checkbox"/>
c. The proposed action may result in the excavation or compaction of the soil profile of active agricultural land.	E3b	<input type="checkbox"/>	<input type="checkbox"/>
d. The proposed action may irreversibly convert agricultural land to non-agricultural uses, either more than 2.5 acres if located in an Agricultural District, or more than 10 acres if not within an Agricultural District.	E1b, E3a	<input type="checkbox"/>	<input type="checkbox"/>
e. The proposed action may disrupt or prevent installation of an agricultural land management system.	E1 a, E1b	<input type="checkbox"/>	<input type="checkbox"/>
f. The proposed action may result, directly or indirectly, in increased development potential or pressure on farmland.	C2c, C3, D2c, D2d	<input type="checkbox"/>	<input type="checkbox"/>
g. The proposed project is not consistent with the adopted municipal Farmland Protection Plan.	C2c	<input type="checkbox"/>	<input type="checkbox"/>
h. Other impacts: _____		<input type="checkbox"/>	<input type="checkbox"/>

**9. Impact on Aesthetic Resources**  
 The land use of the proposed action are obviously different from, or are in sharp contrast to, current land use patterns between the proposed project and a scenic or aesthetic resource. (Part 1. E.1.a, E.1.b, E.3.h.)  
*If "Yes", answer questions a - g. If "No", go to Section 10.*

NO       YES

	Relevant Part I Question(s)	No, or small impact may occur	Moderate to large impact may occur
a. Proposed action may be visible from any officially designated federal, state, or local scenic or aesthetic resource.	E3h	<input type="checkbox"/>	<input type="checkbox"/>
b. The proposed action may result in the obstruction, elimination or significant screening of one or more officially designated scenic views.	E3h, C2b	<input type="checkbox"/>	<input type="checkbox"/>
c. The proposed action may be visible from publicly accessible vantage points: i. Seasonally (e.g., screened by summer foliage, but visible during other seasons) ii. Year round	E3h	<input type="checkbox"/> <input type="checkbox"/>	<input type="checkbox"/> <input type="checkbox"/>
d. The situation or activity in which viewers are engaged while viewing the proposed action is: i. Routine travel by residents, including travel to and from work ii. Recreational or tourism based activities	E3h E2q, E1c	<input type="checkbox"/> <input type="checkbox"/>	<input type="checkbox"/> <input type="checkbox"/>
e. The proposed action may cause a diminishment of the public enjoyment and appreciation of the designated aesthetic resource.	E3h	<input type="checkbox"/>	<input type="checkbox"/>
f. There are similar projects visible within the following distance of the proposed project: 0-1/2 mile 1/2 -3 mile 3-5 mile 5+ mile	D1a, E1a, D1f, D1g	<input type="checkbox"/>	<input type="checkbox"/>
g. Other impacts: _____ _____		<input type="checkbox"/>	<input type="checkbox"/>

**10. Impact on Historic and Archeological Resources**  
 The proposed action may occur in or adjacent to a historic or archaeological resource. (Part 1. E.3.e, f. and g.)  
*If "Yes", answer questions a - e. If "No", go to Section 11.*

NO       YES

	Relevant Part I Question(s)	No, or small impact may occur	Moderate to large impact may occur
a. The proposed action may occur wholly or partially within, or substantially contiguous to, any buildings, archaeological site or district which is listed on or has been nominated by the NYS Board of Historic Preservation for inclusion on the State or National Register of Historic Places.	E3e	<input type="checkbox"/>	<input type="checkbox"/>
b. The proposed action may occur wholly or partially within, or substantially contiguous to, an area designated as sensitive for archaeological sites on the NY State Historic Preservation Office (SHPO) archaeological site inventory.	E3f	<input type="checkbox"/>	<input type="checkbox"/>
c. The proposed action may occur wholly or partially within, or substantially contiguous to, an archaeological site not included on the NY SHPO inventory. Source: _____	E3g	<input type="checkbox"/>	<input type="checkbox"/>

d. Other impacts: _____ _____		<input type="checkbox"/>	<input type="checkbox"/>
e. If any of the above (a-d) are answered "Moderate to large impact may occur", continue with the following questions to help support conclusions in Part 3:			
i. The proposed action may result in the destruction or alteration of all or part of the site or property.	E3e, E3g, E3f	<input type="checkbox"/>	<input type="checkbox"/>
ii. The proposed action may result in the alteration of the property's setting or integrity.	E3e, E3f, E3g, E1a, E1b	<input type="checkbox"/>	<input type="checkbox"/>
iii. The proposed action may result in the introduction of visual elements which are out of character with the site or property, or may alter its setting.	E3e, E3f, E3g, E3h, C2, C3	<input type="checkbox"/>	<input type="checkbox"/>

<b>11. Impact on Open Space and Recreation</b> The proposed action may result in a loss of recreational opportunities or a reduction of an open space resource as designated in any adopted municipal open space plan. <span style="float: right;"><input checked="" type="checkbox"/> NO <input type="checkbox"/> YES</span> (See Part 1. C.2.c, E.1.c., E.2.q.) <i>If "Yes", answer questions a - e. If "No", go to Section 12.</i>			
	<b>Relevant Part I Question(s)</b>	<b>No, or small impact may occur</b>	<b>Moderate to large impact may occur</b>
a. The proposed action may result in an impairment of natural functions, or "ecosystem services", provided by an undeveloped area, including but not limited to stormwater storage, nutrient cycling, wildlife habitat.	D2e, E1b E2h, E2m, E2o, E2n, E2p	<input type="checkbox"/>	<input type="checkbox"/>
b. The proposed action may result in the loss of a current or future recreational resource.	C2a, E1c, C2c, E2q	<input type="checkbox"/>	<input type="checkbox"/>
c. The proposed action may eliminate open space or recreational resource in an area with few such resources.	C2a, C2c E1c, E2q	<input type="checkbox"/>	<input type="checkbox"/>
d. The proposed action may result in loss of an area now used informally by the community as an open space resource.	C2c, E1c	<input type="checkbox"/>	<input type="checkbox"/>
e. Other impacts: _____ _____		<input type="checkbox"/>	<input type="checkbox"/>

<b>12. Impact on Critical Environmental Areas</b> The proposed action may be located within or adjacent to a critical environmental area (CEA). (See Part 1. E.3.d) <span style="float: right;"><input checked="" type="checkbox"/> NO <input type="checkbox"/> YES</span> <i>If "Yes", answer questions a - c. If "No", go to Section 13.</i>			
	<b>Relevant Part I Question(s)</b>	<b>No, or small impact may occur</b>	<b>Moderate to large impact may occur</b>
a. The proposed action may result in a reduction in the quantity of the resource or characteristic which was the basis for designation of the CEA.	E3d	<input type="checkbox"/>	<input type="checkbox"/>
b. The proposed action may result in a reduction in the quality of the resource or characteristic which was the basis for designation of the CEA.	E3d	<input type="checkbox"/>	<input type="checkbox"/>
c. Other impacts: _____ _____		<input type="checkbox"/>	<input type="checkbox"/>

**13. Impact on Transportation**  
 The proposed action may result in a change to existing transportation systems.  NO  YES  
 (See Part 1. D.2.j)  
*If "Yes", answer questions a - f. If "No", go to Section 14.*

	Relevant Part I Question(s)	No, or small impact may occur	Moderate to large impact may occur
a. Projected traffic increase may exceed capacity of existing road network.	D2j	<input type="checkbox"/>	<input type="checkbox"/>
b. The proposed action may result in the construction of paved parking area for 500 or more vehicles.	D2j	<input type="checkbox"/>	<input type="checkbox"/>
c. The proposed action will degrade existing transit access.	D2j	<input type="checkbox"/>	<input type="checkbox"/>
d. The proposed action will degrade existing pedestrian or bicycle accommodations.	D2j	<input type="checkbox"/>	<input type="checkbox"/>
e. The proposed action may alter the present pattern of movement of people or goods.	D2j	<input type="checkbox"/>	<input type="checkbox"/>
f. Other impacts: _____ _____		<input type="checkbox"/>	<input type="checkbox"/>

**14. Impact on Energy**  
 The proposed action may cause an increase in the use of any form of energy.  NO  YES  
 (See Part 1. D.2.k)  
*If "Yes", answer questions a - e. If "No", go to Section 15.*

	Relevant Part I Question(s)	No, or small impact may occur	Moderate to large impact may occur
a. The proposed action will require a new, or an upgrade to an existing, substation.	D2k	<input checked="" type="checkbox"/>	<input type="checkbox"/>
b. The proposed action will require the creation or extension of an energy transmission or supply system to serve more than 50 single or two-family residences or to serve a commercial or industrial use.	D1f, D1q, D2k	<input checked="" type="checkbox"/>	<input type="checkbox"/>
c. The proposed action may utilize more than 2,500 MWhrs per year of electricity.	D2k	<input checked="" type="checkbox"/>	<input type="checkbox"/>
d. The proposed action may involve heating and/or cooling of more than 100,000 square feet of building area when completed.	D1g	<input checked="" type="checkbox"/>	<input type="checkbox"/>
e. Other Impacts: _____ _____		<input type="checkbox"/>	<input type="checkbox"/>

**15. Impact on Noise, Odor, and Light**  
 The proposed action may result in an increase in noise, odors, or outdoor lighting.  NO  YES  
 (See Part 1. D.2.m., n., and o.)  
*If "Yes", answer questions a - f. If "No", go to Section 16.*

	Relevant Part I Question(s)	No, or small impact may occur	Moderate to large impact may occur
a. The proposed action may produce sound above noise levels established by local regulation.	D2m	<input type="checkbox"/>	<input type="checkbox"/>
b. The proposed action may result in blasting within 1,500 feet of any residence, hospital, school, licensed day care center, or nursing home.	D2m, E1d	<input type="checkbox"/>	<input type="checkbox"/>
c. The proposed action may result in routine odors for more than one hour per day.	D2o	<input type="checkbox"/>	<input type="checkbox"/>

d. The proposed action may result in light shining onto adjoining properties.	D2n	<input type="checkbox"/>	<input type="checkbox"/>
e. The proposed action may result in lighting creating sky-glow brighter than existing area conditions.	D2n, E1a	<input type="checkbox"/>	<input type="checkbox"/>
f. Other impacts: _____ _____		<input type="checkbox"/>	<input type="checkbox"/>

**16. Impact on Human Health**

The proposed action may have an impact on human health from exposure to new or existing sources of contaminants. (See Part 1.D.2.q., E.1. d. f. g. and h.)  
*If "Yes", answer questions a - m. If "No", go to Section 17.*

NO

YES

	Relevant Part I Question(s)	No, or small impact may occur	Moderate to large impact may occur
a. The proposed action is located within 1500 feet of a school, hospital, licensed day care center, group home, nursing home or retirement community.	E1d	<input type="checkbox"/>	<input type="checkbox"/>
b. The site of the proposed action is currently undergoing remediation.	E1g, E1h	<input type="checkbox"/>	<input type="checkbox"/>
c. There is a completed emergency spill remediation, or a completed environmental site remediation on, or adjacent to, the site of the proposed action.	E1g, E1h	<input type="checkbox"/>	<input type="checkbox"/>
d. The site of the action is subject to an institutional control limiting the use of the property (e.g., easement or deed restriction).	E1g, E1h	<input type="checkbox"/>	<input type="checkbox"/>
e. The proposed action may affect institutional control measures that were put in place to ensure that the site remains protective of the environment and human health.	E1g, E1h	<input type="checkbox"/>	<input type="checkbox"/>
f. The proposed action has adequate control measures in place to ensure that future generation, treatment and/or disposal of hazardous wastes will be protective of the environment and human health.	D2t	<input type="checkbox"/>	<input type="checkbox"/>
g. The proposed action involves construction or modification of a solid waste management facility.	D2q, E1f	<input type="checkbox"/>	<input type="checkbox"/>
h. The proposed action may result in the unearthing of solid or hazardous waste.	D2q, E1f	<input type="checkbox"/>	<input type="checkbox"/>
i. The proposed action may result in an increase in the rate of disposal, or processing, of solid waste.	D2r, D2s	<input type="checkbox"/>	<input type="checkbox"/>
j. The proposed action may result in excavation or other disturbance within 2000 feet of a site used for the disposal of solid or hazardous waste.	E1f, E1g E1h	<input type="checkbox"/>	<input type="checkbox"/>
k. The proposed action may result in the migration of explosive gases from a landfill site to adjacent off site structures.	E1f, E1g	<input type="checkbox"/>	<input type="checkbox"/>
l. The proposed action may result in the release of contaminated leachate from the project site.	D2s, E1f, D2r	<input type="checkbox"/>	<input type="checkbox"/>
m. Other impacts: _____ _____			



**17. Consistency with Community Plans**

The proposed action is not consistent with adopted land use plans.  
(See Part 1. C.1, C.2. and C.3.)

NO

YES

*If "Yes", answer questions a - h. If "No", go to Section 18.*

	Relevant Part I Question(s)	No, or small impact may occur	Moderate to large impact may occur
a. The proposed action's land use components may be different from, or in sharp contrast to, current surrounding land use pattern(s).	C2, C3, D1a E1a, E1b	<input type="checkbox"/>	<input type="checkbox"/>
b. The proposed action will cause the permanent population of the city, town or village in which the project is located to grow by more than 5%.	C2	<input type="checkbox"/>	<input type="checkbox"/>
c. The proposed action is inconsistent with local land use plans or zoning regulations.	C2, C2, C3	<input type="checkbox"/>	<input type="checkbox"/>
d. The proposed action is inconsistent with any County plans, or other regional land use plans.	C2, C2	<input type="checkbox"/>	<input type="checkbox"/>
e. The proposed action may cause a change in the density of development that is not supported by existing infrastructure or is distant from existing infrastructure.	C3, D1c, D1d, D1f, D1d, E1b	<input type="checkbox"/>	<input type="checkbox"/>
f. The proposed action is located in an area characterized by low density development that will require new or expanded public infrastructure.	C4, D2c, D2d D2j	<input type="checkbox"/>	<input type="checkbox"/>
g. The proposed action may induce secondary development impacts (e.g., residential or commercial development not included in the proposed action)	C2a	<input type="checkbox"/>	<input type="checkbox"/>
h. Other: _____ _____		<input type="checkbox"/>	<input type="checkbox"/>

**18. Consistency with Community Character**

The proposed project is inconsistent with the existing community character.  
(See Part 1. C.2, C.3, D.2, E.3)

NO

YES

*If "Yes", answer questions a - g. If "No", proceed to Part 3.*

	Relevant Part I Question(s)	No, or small impact may occur	Moderate to large impact may occur
a. The proposed action may replace or eliminate existing facilities, structures, or areas of historic importance to the community.	E3e, E3f, E3g	<input type="checkbox"/>	<input type="checkbox"/>
b. The proposed action may create a demand for additional community services (e.g. schools, police and fire)	C4	<input type="checkbox"/>	<input type="checkbox"/>
c. The proposed action may displace affordable or low-income housing in an area where there is a shortage of such housing.	C2, C3, D1f D1g, E1a	<input type="checkbox"/>	<input type="checkbox"/>
d. The proposed action may interfere with the use or enjoyment of officially recognized or designated public resources.	C2, E3	<input type="checkbox"/>	<input type="checkbox"/>
e. The proposed action is inconsistent with the predominant architectural scale and character.	C2, C3	<input type="checkbox"/>	<input type="checkbox"/>
f. Proposed action is inconsistent with the character of the existing natural landscape.	C2, C3 E1a, E1b E2g, E2h	<input type="checkbox"/>	<input type="checkbox"/>
g. Other impacts: _____ _____		<input type="checkbox"/>	<input type="checkbox"/>





# Resolution of Positive Declaration



**RESOLUTION ISSUING POSTIVE DECLARATION AND REQUIRING  
PREPARATION OF DRAFT ENVIRONMENTAL IMPACT STATEMENT**

*Banta 935 Union Avenue Site Plan*  
PB #17-04  
SBL 4-1-12.11

**WHEREAS**, an application was made to the Planning Board of the Town of New Windsor for site plan approval by Banta Hospitality, Inc. (the “applicant”) for a project described as the “Banta 935 Union Avenue Site Plan”; and

**WHEREAS**, the subject site consists of +/- 2.81 acres of land located at 935 Union Avenue (N.Y.S. Route 300) in the Town of New Windsor, consisting of one tax parcel identified on the tax map as Section 4, Block 1, Lot 12.11 (SBL 4-1-12.11); and

**WHEREAS**, the applicant proposes to develop one (1) 4-story hotel comprising 93 guestrooms on the 2.81 +/- acre site located on one parcel in the Town of New Windsor. The Proposed Action will also include the installation of appurtenant utilities and parking facilities. The site is located in the Highway Commercial Zoning District; and

**WHEREAS**, the applicant has submitted a fully executed Full Environmental Assessment Form (“EAF”) pursuant to the New York State Environmental Quality Review Act (“SEQRA”); and

**WHEREAS**, this is an Unlisted Action pursuant to SEQRA; and

**WHEREAS**, the Planning Board is conducting a Coordinated SEQRA review for this project; and

**WHEREAS**, the Planning Board declared its intent to become the Lead Agency with respect to the Proposed Action and on April 26, 2017, circulated a Notice of Intent to be Lead Agency to other involved and interested agencies; and

**WHEREAS**, on July 12, 2017, having received no objection to the proposed Lead Agency designation within thirty (30) days after circulation of the Notice of Intent, the Planning Board designated itself as Lead Agency for environmental review of the Proposed Action; and

**WHEREAS**, potential environmental impacts associated with the Proposed Action are as identified in the EAF submitted by the Applicant; such impacts which may be reasonably expected to result from the Proposed Action, have been compared to the criteria for determining significance identified in 6 N.Y.C.R.R. §617.7(c)(1) and in accordance with 6 N.Y.C.R.R. §617.7(c)(2) and (3); and

**WHEREAS**, the Planning Board finds that the Proposed Action may result in one or more significant impacts on the environment, including the Proposed Action’s potential impact on drainage and storm water discharges in an area of heightened sensitivity given water quality concerns in the nearby Washington Lake, a potable reservoir; increased erosion due to physical

disturbance and vegetation removal at the site which is located within in the Town of New Windsor's Watershed Protection Overlay District; traffic and the capacity of the existing road network; water (potable and fire-fighting) resources; and sewer resources. An Environmental Impact Statement ("EIS") will be prepared to address the Proposed Action's potential impacts.

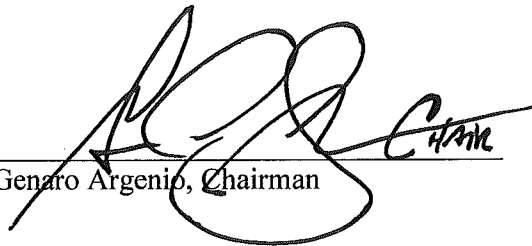
**NOW THEREFORE**, the Planning Board directs the following:

1. The Proposed Action is hereby designated an Unlisted Action pursuant to SEQRA;
2. The Planning Board hereby determines that the Proposed Action may result in one or more potentially significant environmental impacts and hereby adopts and issues the Positive Declaration – Notice of Intent to Prepare a Draft Environmental Impact Statement for the reasons set forth therein;
3. The attached Notice of Intent to Prepare a Draft Environmental Impact Statement and Lead Agency Determination of Significance shall be circulated and filed in accordance with the requirements of 6 N.Y.C.R.R. §617.12;
4. The applicant is directed to draft and submit a proposed scope for a Draft Environmental Impact Statement in accordance with the requirements of 6 N.Y.C.R.R. §617.8 and 6 N.Y.C.R.R. §617.9; and
5. At the conclusion of the scoping process and acceptance of a final scoping document by the Planning Board, the applicant is hereby directed to prepare a Draft EIS for the Project.

Upon motion made by Member David Sherman, seconded by Member Howard Brown, on July 12, 2017, the foregoing resolution was adopted as follows:

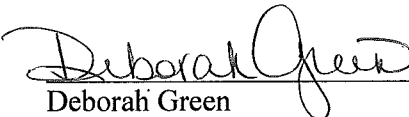
Member, Daniel Gallagher	<input checked="" type="radio"/> Aye	<input type="radio"/> Nay	<input type="radio"/> Abstain	<input type="radio"/> Absent
Member, Howard Brown	<input checked="" type="radio"/> Aye	<input type="radio"/> Nay	<input type="radio"/> Abstain	<input type="radio"/> Absent
Member, Harry Ferguson	<input checked="" type="radio"/> Aye	<input type="radio"/> Nay	<input type="radio"/> Abstain	<input type="radio"/> Absent
Member, David Sherman	<input checked="" type="radio"/> Aye	<input type="radio"/> Nay	<input type="radio"/> Abstain	<input type="radio"/> Absent
Chairman, Genaro Argenio	<input checked="" type="radio"/> Aye	<input type="radio"/> Nay	<input type="radio"/> Abstain	<input type="radio"/> Absent

Dated: July 25, 2017  
New Windsor, New York



Genaro Argenio, Chairman

Filed in the Office of the Town Clerk on this 26<sup>th</sup> day of July, 2017.



Deborah Green  
Town Clerk



# Adopted Scoping Document





# **FINAL Scoping Document**

**for the Proposed**

## **935 Union Avenue Site Plan Application**

**Located at**

**935 Union Avenue  
Town of New Windsor  
Orange County, New York  
NWPB No. 17-04**

**September 5, 2017**

The Planning Board of the Town of New Windsor, having been confirmed as Lead Agency, having determined that the project is a Type 1 action, and having made a Positive Declaration on July 12, 2017 has issued this document to guide the preparation of a Draft Environmental Impact Statement.

**Lead Agency and Contact Person:**

Genaro Argenio, Planning Board Chairman  
New Windsor Planning Board  
555 Union Avenue  
New Windsor, New York 12553  
(845) 563-4618

**Project Sponsor:**

Banta Hospitality  
842 Main Street  
Poughkeepsie, New York 12603  
(914) 474 8235

**Prepared By:**

M.A. Day Engineering, PC  
3 Van Wyck Lane  
Suite 2  
Wappingers Falls, New York 12590  
(845) 223-3202

Date Submitted: \_\_\_\_\_

Date Adopted: November 8, 2017

## **Description of Action:**

The subject property is a 2.18-acre parcel located at 935 Union Avenue (a.k.a. Route 300) in the Town of New Windsor, Orange County, New York. The Proposed Action involves the removal of an existing 5,575 square foot, wood-frame & masonry building on the subject parcel which has served as a restaurant for a number of years and constructing a four-story limited-service hotel with 93 rooms and requisite parking on the site. The site will be landscaped with proper lighting and a re-aligned entrance onto Union Avenue.

## **Areas of Identified Environmental Concern:**

During the Planning Board meeting of July 12, 2017, at the initial phase of SEQRA, the Planning Board, as the Lead Agency reviewed Part 1 of the Long Environmental Assessment Form submitted by the Project Sponsor. The Planning Board raised the following areas of potential environmental concern:

- Impacts that the Proposed Action may have on drainage and storm water discharges.
- Impacts that the Proposed Action may have on erosion due to physical disturbance and removal of vegetation on the site which is in the Town of New Windsor Watershed Protection Overlay District, including Washington Lake, a City of Newburgh water reservoir.
- Impacts that the Proposed Action may have on traffic on NYS Route 300 and capacity of the existing road network.
- Impacts that the Proposed Action may have on existing domestic water and fire-fighting resources.
- Impacts the Proposed Action may have on sanitary sewer resources.

## **Required Approvals:**

The following is an anticipated list of approvals and permits that will be required along with the involved agencies.

### **A. Town of New Windsor Planning Board:**

1. Approval of Site Plan.

### **B. Town of New Windsor**

1. **Water and Sewer Department**
  - a) Water and Sewer Utilities
2. **Building Department**
  - a) Building Permits

### **C. Orange County**

1. Health Department
  - (a) Water service.

**D. NYSDOT:**

1. Highway Work Permit.

**E. NYSDEC:**

1. General SPDES GP-0-15-002 permit.

The following is an anticipated list of interested agencies that will included in the DEIS circulation.

- A. Town of New Windsor Town Board
- B. Town of New Windsor Highway Department
- C. Federal Aviation Administration
- D. Port Authority of NY and NJ
- E. NYS Office of Parks, Recreation and Historic Preservation
- F. New York State Health Department
- G. Orange County Department of Planning
- H. Orange County Department of Public Works
- I. City of Newburgh \* hard copy of SWPPP will also be forwarded as a courtesy referral
- J. Town of Newburgh
- K. New Windsor Historian
- L. Vails Gate Fire Department
- M. New Windsor Ambulance Corps.

**General Guidelines:**

The Draft Environmental Impact Statement (“DEIS”) shall address all items outlined in this Scoping Document in accordance with the format outlined in the Scoping Document.

The DEIS document shall be written in the third person. The conclusions and opinions offered in the DEIS Document should be identified as those of the “Project Sponsor” or “Applicant”.

Appropriate figures, tables, maps and diagrams shall be accompany all narrative discussions included in the DEIS Document. Whenever more appropriate, a graphic format will be used to describe subject matter.

The DEIS Document shall be reviewed to ensure consistency between the various sections of the DEIS Document. The DEIS shall be written so as to cross-reference information whenever possible to eliminate repeating information throughout the document. Impacts should be explained in language that the layperson can readily understand. Technical studies and discussions should be summarized. If technical reports are required to be included in the DEIS Document, they will be included in the appendices of the DEIS Document.

All discussions of mitigation measures should consider all those measures mentioned in the Scoping Document. As deemed necessary by the lead agency, mitigation measures shall be incorporated into the Proposed Action.

The intent of the DEIS is to convey general and technical information for the Proposed Action and potential environmental impacts that may be caused by the Proposed Action to the Lead Agency, Involved Agencies, Interested Agencies and the general public interested in the project. The author of the DEIS Document should keep in mind the intent of the Document and the audience. Each section in the Document shall include enough information to ensure that most readers will understand and be able to make decisions based on the information provided.

The DEIS Document will become, upon acceptance by the Lead Agency, a document that will support objective findings on approvals requested as part of the application. The Author shall avoid subjective statements with respect to potential impacts. The DEIS Document should only include objective statements and conclusions based upon technical documents, reports, analyses, etc.

Reduced scale plans shall be printed on 11"x17" sheets and will be included in the appendices of the DEIS Document. Interested Agencies shall be provided with an electronic version using Adobe Portable Document (PDF) format on a CD. They will be informed where they may inspect a full size paper copy of the DEIS Document. Interested Agencies will also be informed as to how they can request and obtain a printed copy of the DEIS Document. The entire DEIS Document shall be provided, in PDF format, for posting on the Town of New Windsor's website, once it has been deemed "complete" by the Lead Agency.

## **Scope of the Environmental Impact Statement:**

The Following Pages describe the content and format of the Document.

### **I. Cover Sheet**

#### **A. The DEIS shall start with a cover sheet and opening pages to include:**

1. Identifying the document as a Draft Environmental Impact Statement,
2. Name and location of the project,
3. Date submitted to the Lead Agency,
4. Date of acceptance of the DEIS (to be filled in when known).
5. Date of public hearing and date by which comments are due (to be filled in when known).
6. Name, address, telephone number and contact person of the lead agency.
8. Name, address, telephone number and contact person of the project sponsor/applicant.
9. Name, address, telephone number and contact person of the preparer of the DEIS.

10. Following the cover sheet, a list of all interested and involved agencies and parties.

**B. Consultants:**

The DEIS shall include a list of the consultants who worked on the DEIS and the name, address and area of responsibility of each consultant. The consultants' professional qualifications shall be placed in an appendix to the DEIS or included with each professional's report. The Planning Board reserves the right to approve or reject each consultant.

## **II. Table of Contents**

The DEIS shall include a Table of Contents - The table should include all subsections, map, figures, tables, appendices and volumes with appropriate page numbers.

## **III. Executive Summary**

The Executive Summary shall be a summary of the information found in the body of the document. Information only found in the body of the document will be included in the Executive Summary. All figures, tables and drawings will only be referenced in the Executive Summary. They will not be recreated in the executive summary.

## **IV. Project Description**

**A. Site Location and Description of the Proposed Project.**

1. Narrative description and graphical representation of project location,
2. Description of the existing use of the site,
3. Tax map designation,
4. Abutting streets,
5. Existing utilities and infrastructure,
6. Surrounding land uses, including the proposed use for adjacent parcel
7. Existing zoning categories,
8. Rights of Way,
9. Easements,
10. Legal agreements that will affect the use and development of the site, including access over adjoining/adjacent properties.

**B. Description of Proposed Action:**

1. A narrative and graphical representation about the Proposed Action addressing the proposed site, the proposed use, the general layout, site access, parking requirements and layout, internal circulation and amenities,
2. Architectural Renderings and elevations of the proposed buildings with a description of the materials,
3. Proposed landscaping plans will be discussed and referenced,

4. A discussion of the proposed impervious surfaces shall be discussed.
5. Utility usage (water, sewer, etc.)

**C. Project Purpose, Need and Benefits:**

1. This section will include a discussion of the objective of the project sponsor for the project,
2. Compliance with the Town's Comprehensive Plan will be discussed,
3. Positive fiscal, employment and economic benefits.

**D. Construction and Operation:**

1. This section will address the anticipated construction timeline and the anticipated operational hours during the construction of the project.

**E. Required Permits & Approvals – Involved & Interested Agencies**

1. Involved Agencies and required approvals: A complete list of involved agencies, including name and address, and all permits or approvals required.
2. Interested Parties: A complete list of all agencies, persons or groups who have expressed an interest in reviewing and commenting upon the DEIS.

## **V. Existing Conditions, Anticipated Impacts, and Mitigation**

**A. Land Use, Zoning & Public Policy:**

**1. Existing Conditions:**

- a) Provide a discussion and a graphic depicting the current Land Use & Zoning within ½ mile of the Project Site.

**2. Potential Impacts:**

- a) Provide a discussion about the project relationship with the current Orange County and Town of New Windsor Comprehensive plan and the project relationship with current surrounding land uses including sensitive areas such as the City of Newburgh reservoir, Stewart International Airport and the New York State Thruway.

**3. Proposed Mitigation:**

- a) Proposed mitigation measures for identified adverse environmental impacts will be outlined.

**B. Geology, Soils and Topography:**

**1. Existing Conditions:**

- a) Subsurface: Provide a discussion about the composition and thickness of subsurface material, depth to bedrock and rock

outcrops utilizing site data and information provided in the Orange County Soils Survey. Results of any on site soil borings or subsurface investigations to better describe subsurface conditions.

**2. Potential Impacts:**

- a) Provide a discussion about the site grading requirements,
- b) Land disturbance and potential impacts from site grading with respect to soil erosion, slope stabilization and rock removal.
- c) Increased impervious surface,
- d) Need for blasting.

**3. Proposed Mitigation**

- a) General outline of grading plan, specific plan and details will be provided with the Site Plan and construction plans.
- b) General outline for preparation of a Stormwater Pollution Prevention Plan, construction sequence plans, concept and principles for control of erosion and sedimentation, temporary sediment basins and first flush basins and other appropriate BMPs.
  - (1) Follow “New York Guidelines for Urban Erosion and Sediment Control”
  - (2) Specifically provide soil erosion plan to protect areas of steep slope.
- c) Siltation fencing and diversion swales, if applicable.
- d) Dispose of construction and demolition debris in a licensed site.
- e) Use topsoil stockpiled during construction for restoration and landscaping.
- f) Minimize disturbance of non-construction areas.
- g) Avoid construction on steep slopes.
- h) Temporary access control.
- i) Compliance with Federal, State and Local blasting regulations.

**C. Groundwater:**

**1. Existing Conditions:**

- a) A discussion shall be provided of the adjacent Silver Stream Road Landfill and any known areas of groundwater contamination.

**2. Potential Impacts:**

- a) A discussion shall be provided addressing any potential impacts to the groundwater due the Proposed Action.
- b) A discussion shall be provided addressing the potential impacts on existing groundwater plumes or treatment areas in the area of the Proposed Action.

- c) Cumulative impacts associated with the construction of the Proposed Action and the proposed Windsor Hospitality Site Plan Amendments will be identified and discussed.

**3. Proposed Mitigation:**

- a) Describe proposed and potential mitigation measures for the identified environmental impacts.
- b) Identify unavoidable adverse environmental impacts.
- c) Cumulative impacts associated with the construction of this project and Windsor Hospitality Site Plan Amendments will be identified and discussed.

**D. Infrastructure and Utilities:**

**1. Existing Conditions:**

- a) A discussion shall be provided of all existing utilities that service the site including, water, sanitary sewer, gas and electric.

**2. Potential Impacts:**

- a) Describe the proposed sewer collection facilities that will be utilized for the Proposed Action.
- b) A discussion of the anticipated average daily domestic water and sewage demands for the Proposed Action.
- c) Provide a discussion of the adequacy of the existing water supply and sewer collection system.
- d) Provide an assessment of the existing water supply pressure for fire-fighting purposes.
- e) Provide a discussion of the adequacy of electric and gas service to supply the Proposed Action.
- f) Cumulative impacts associated with the construction of the Proposed Action and the proposed Windsor Hospitality Site Plan Amendments will be identified and discussed.

**3. Proposed Mitigation:**

- a) Describe proposed and potential mitigation measures for the identified environmental impacts.

**E. Stormwater Management**

**1. Existing Conditions:**

- a) Provide location and description of existing drainage patterns.
- b) Discuss permit requirements.
- c) Discuss on-site pre-development stormwater flow rates.
- d) The drainage analysis shall be made using SCS TR-55 methodology.



## **2. Potential Impacts:**

- a) Discuss on-site post-development stormwater flow rates in comparison to pre-development stormwater flow rates.
- b) Address compliance with NYSDEC regulations for stormwater per the NYSDEC Stormwater Management Design Manual.
- c) Discuss potential impacts to City of Newburgh potable water supply.
- d) Cumulative impacts associated with the construction of the Proposed Action and the proposed Windsor Hospitality Site Plan Amendments will be identified and discussed.

## **3. Proposed Mitigation:**

- a) Provide a discussion of proposed mitigation measures for the stormwater such as:
  - (1) Follow suggestions contained in the EPA Phase II regulations.
    - (a) Temporary sediment basins.
    - (b) Erosion control measures required by NYSDEC.
    - (c) Stormwater collection system including detention or retention basins
    - (d) Preparation of a Storm water Pollution Prevention Plan.
    - (e) Avoid direct discharge to surface water bodies.
  - (2) Potential for stormwater treatment for water quality.

## **F. Traffic and Roadways:**

### **1. Existing Conditions:**

- a) A traffic impact study (TIS) shall be prepared which will evaluate the potential traffic impacts in the area of the Proposed Action which may be caused by the Proposed Action.
- b) The TIS will discuss existing traffic conditions in the area of the Proposed Action.
- c) Turning movements volumes shall be counted at 15-minute intervals during typical peak travel times including:
  - (1) Weekday AM
  - (2) Weekday PM
  - (3) Saturday Midday
- d) This information will be provided for the following intersections:
  - (1) The intersection of Union Avenue (a.k.a. NYS Route 300) and Little Britain Road (a.k.a. NYS Route 207),
  - (2) The driveway for the site project onto Union Avenue.
  - (3) The driveway for the proposed Windsor Hospitality Hotel Site,

- (4) The intersection with Union Avenue and Liner Road.
- e) The peak hour traffic volumes shall be determined for each period.
  - f) An inventory of existing roads including lane widths, number of lanes, channelization, traffic control devices, traffic light sequencing and other conditions which control traffic flow in the area of the Propose Action.
  - g) The intersections that are the subject of study shall be analyzed using methodologies contained in the *Highway Capacity Manual (2010)* published by the Transportation Research Board. The levels-of-service shall be included in the analyses of each intersection studied.
  - h) A “no-build” scenario shall be included as part of the TIS which will address the traffic conditions at some point in the future assuming that the Proposed Action is not developed. The analysis will also include consideration of traffic conditions if the restaurant already existing on-site was fully operational.
  - i) Future conditions for traffic shall be projected in the TIS based on a historic background growth factor and proposed projects in the region that may affect traffic in the area of the Proposed Action (cumulative impact analysis).
  - j) Motor vehicle accident history will be discussed in the TIS and in the DEIS Document.

## **2. Potential Impacts**

- a) Compute the projected levels-of-service for the intersections under study using a growth rate based on historic data in background traffic, the impact from known proposed developments and the Proposed Action using trip generation rates for the proposed use.
- b) The TIS will address increase in traffic volumes, decreases in LOS, Describe the cumulative and additive impacts with recent, planned and potential development including impacts derived by recent improvements in the local roadways.
- c) Cumulative impacts associated with the construction of the Proposed Action and the proposed Windsor Hospitality Site Plan Amendments will be identified and discussed.

## **3. Proposed Mitigation:**

- a) Describe any proposed traffic improvements which may be warranted due to the implementation of the Prosed Action.
- b) Analyze the “Build” scenario with the proposed mitigations in place and provide a discussion of the analysis. Construction work phasing, intended locations of construction access, traffic impacts from construction vehicles and materials

staging/construction worker parking will also be discussed and analyzed.

## **G. Community Services:**

### **1. Existing Conditions:**

- a) Describe the existing community service facilities that will serve the Proposed Action.

### **2. Potential Impacts:**

- a) Describe the potential impacts that may be anticipated due to the development of the Proposed Action.
- b) Cumulative impacts associated with the construction of the Proposed Action and the proposed Windsor Hospitality Site Plan Amendments will be identified and discussed.

### **3. Proposed Mitigation:**

- a) Describe proposed mitigation measures for the identified adverse impacts.

## **H. Fiscal Analysis:**

### **1. Existing Conditions:**

- a) Describe the existing taxes generated by the project site.

### **2. Potential Impacts:**

- a) Provide an analysis of the projected tax revenues for the Proposed Action.
- b) Provide a summary of costs to the community using a proportional valuation fiscal impact method.
- c) Cumulative impacts associated with the construction of the Proposed Action and the proposed Windsor Hospitality Site Plan Amendments will be identified and discussed.

### **3. Proposed Mitigation:**

- a) Describe the proposed mitigation for any identified adverse impact.

## **I. Visual Character:**

### **1. Existing Conditions:**

- a) Describe the existing project site using photographs taken from Union Avenue.
- b) Present viewshed photographs from any recreational areas that may be visually impacted by the Proposed Action.

**2. Potential Impacts:**

- a) Architectural Renderings shall be included in the document that depict proposed colors and materials to be used on the proposed building.
- b) Provide a landscaping plan in the DEIS Document which depicts the proposed landscaping materials and quantities that will be planted as part of the Proposed Action.
- c) Provide cross-sections through the project site depicting the proposed buildings and landscaping

**3. Proposed Mitigation:**

- a) Describe the proposed mitigation for any identified adverse impact.

**J. Flora and Fauna:**

**1. Existing Conditions:**

- a) Contact the NYSDEC to determine potential protected or endangered species or habitat that may exist on the project site.
- b) Describe the existing conditions at the project site using photographs, if applicable.

**2. Potential Impacts:**

- a) Describe any potential impacts to endangered or protected species that may exist on the site.

**3. Proposed Mitigation:**

- a) Describe the proposed mitigation for any identified adverse impact.

## **VI. Construction Impacts**

This section shall provide a discussion of the construction schedule for the Proposed Action. The hours of daily activity will be discussed along with the anticipated work days. Any environmental impacts that are related to the construction phase of the project will be discussed in this section. A discussion will be included about blasting, if applicable. Cumulative impacts associated with the construction of the Proposed Action and the proposed Windsor Hospitality Site Plan Amendments will be identified and discussed. Construction work phasing, intended locations of construction access, traffic impacts from construction vehicles and materials staging/construction worker parking will also be discussed and analyzed.

## **VII. Project Alternatives**

### **A. No Build Alternative:**

A discussion will be included about the “no-build” scenario depicting the site to remain in its existing condition

### **B. Other Alternatives:**

A discussion will be included which addresses the development of the site using other permitted uses in the HC zone which are identified as part of the preparation of the DEIS Document, including a operating the existing restaurant on the site or any other permitted uses that may only require one accessway from Union Avenue.

## **VIII. Other Environmental Impacts**

### **A. Unavoidable Adverse Impacts.**

### **B. Irreversible and Irretrievable Commitment of Resources.**

### **C. Growth-Inducing, Cumulative, and Secondary Impacts.**

### **D. Effects of Energy Use and Conservation.**

## **IX. Appendices**

### **A. SEQRA Documentation**

### **B. SWPPP and supporting data**

### **C. Correspondence.**

### **D. Consultant Qualifications.**



## **B. Reports**

- McGoey, Hauser & Edsall Report of Town Landfill – September 2016
- M.A. Day Engineering - Stormwater Pollution Prevention Plan – April 17, 2018
- AKRF, Inc. Traffic Study
- Ecological Solutions – Threatened & Endangered Species Habitat Suitability Report – April 14, 2018





McGoey, Hauser & Edsall Report of Town  
Landfill – September 2016





Enclosure 2  
**NEW YORK STATE DEPARTMENT OF ENVIRONMENTAL CONSERVATION**  
 Site Management Periodic Review Report Notice  
 Institutional and Engineering Controls Certification Form



	Site Details	Box 1
Site No. 336019		
<b>Site Name New Windsor Town Landfill</b>		
Site Address: Silver Stream Road	Zip Code: 12550	
City/Town: New Windsor		
County: Orange		
Site Acreage: 14.0		
Reporting Period: June 01, 2013 to June 01, 2016		
		YES NO
1. Is the information above correct?		<input checked="" type="checkbox"/> <input type="checkbox"/>
If NO, include handwritten above or on a separate sheet.		
2. Has some or all of the site property been sold, subdivided, merged, or undergone a tax map amendment during this Reporting Period?		<input type="checkbox"/> <input checked="" type="checkbox"/>
3. Has there been any change of use at the site during this Reporting Period (see 6NYCRR 375-1.11(d))?		<input type="checkbox"/> <input checked="" type="checkbox"/>
4. Have any federal, state, and/or local permits (e.g., building, discharge) been issued for or at the property during this Reporting Period?		<input type="checkbox"/> <input checked="" type="checkbox"/>
<b>If you answered YES to questions 2 thru 4, include documentation or evidence that documentation has been previously submitted with this certification form.</b>		
5. Is the site currently undergoing development?		<input type="checkbox"/> <input checked="" type="checkbox"/>

		Box 2
		YES NO
6. Is the current site use consistent with the use(s) listed below? Closed Landfill		<input checked="" type="checkbox"/> <input type="checkbox"/>
7. Are all ICs/ECs in place and functioning as designed?		<input checked="" type="checkbox"/> <input type="checkbox"/>

**IF THE ANSWER TO EITHER QUESTION 6 OR 7 IS NO, sign and date below and DO NOT COMPLETE THE REST OF THIS FORM. Otherwise continue.**

**A Corrective Measures Work Plan must be submitted along with this form to address these issues.**

George A. Green  
 Signature of Owner, Remedial Party or Designated Representative

8/31/16  
 Date

**Description of Institutional Controls**ParcelOwnerInstitutional Control

3-1-2

Town of New Windsor

Ground Water Use Restriction  
Landuse Restriction  
O&M Plan

A Deed Restriction was filed on September 22, 2010 which prohibits groundwater use and land use (industrial use).

**Description of Engineering Controls**ParcelEngineering Control

3-1-2

Cover System  
Fencing/Access Control

The landfill has a Part 360 cap in place, and the entire site is fenced to restrict access.

**Periodic Review Report (PRR) Certification Statements**

1. I certify by checking "YES" below that:

a) the Periodic Review report and all attachments were prepared under the direction of, and reviewed by, the party making the certification;

b) to the best of my knowledge and belief, the work and conclusions described in this certification are in accordance with the requirements of the site remedial program, and generally accepted engineering practices; and the information presented is accurate and complete.

YES NO

2. If this site has an IC/EC Plan (or equivalent as required in the Decision Document), for each Institutional or Engineering control listed in Boxes 3 and/or 4, I certify by checking "YES" below that all of the following statements are true:

(a) the Institutional Control and/or Engineering Control(s) employed at this site is unchanged since the date that the Control was put in-place, or was last approved by the Department;

(b) nothing has occurred that would impair the ability of such Control, to protect public health and the environment;

(c) access to the site will continue to be provided to the Department, to evaluate the remedy, including access to evaluate the continued maintenance of this Control;

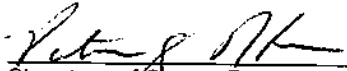
(d) nothing has occurred that would constitute a violation or failure to comply with the Site Management Plan for this Control; and

(e) if a financial assurance mechanism is required by the oversight document for the site, the mechanism remains valid and sufficient for its intended purpose established in the document.

YES NO

**IF THE ANSWER TO QUESTION 2 IS NO, sign and date below and  
DO NOT COMPLETE THE REST OF THIS FORM. Otherwise continue.**

**A Corrective Measures Work Plan must be submitted along with this form to address these issues.**

  
Signature of Owner, Remedial Party or Designated Representative

MH&E

31 August 2016

Date

IC CERTIFICATIONS  
SITE NO. 336019

Box 6

**SITE OWNER OR DESIGNATED REPRESENTATIVE SIGNATURE**

I certify that all information and statements in Boxes 1, 2, and 3 are true. I understand that a false statement made herein is punishable as a Class "A" misdemeanor, pursuant to Section 210.45 of the Penal Law.

I George A. Green at 555 Union Avenue New Windsor, NY 12553  
print name print business address

am certifying as Town Supervisor (Owner or Remedial Party)

for the Site named in the Site Details Section of this form.

George A. Green  
Signature of Owner, Remedial Party, or Designated Representative  
Rendering Certification

8/31/16  
Date

IC/EC CERTIFICATIONS

Box 7

Qualified Environmental Professional Signature

I certify that all information in Boxes 4 and 5 are true. I understand that a false statement made herein is punishable as a Class "A" misdemeanor, pursuant to Section 210.45 of the Penal Law.

I Mark J. Edsall at 33 Airport Center Drive New Windsor, NY 12553  
print name print business address

am certifying as a Qualified Environmental Professional for the Town of New Windsor  
(Owner or Remedial Party)

  
Signature of Qualified Environmental Professional, for  
the Owner or Remedial Party, Rendering Certification



8/31/16  
Date







McGÓEY, HAUSER and EDSALL  
CONSULTING ENGINEERS D.P.C.

MARK J. EDSALL, P.E., P.P. (NY, NJ & PA)  
MICHAEL W. WEEKS, P.E. (NY, NJ & PA)  
MICHAEL J. LAMOREAUX, P.E. (NY, NJ, PA, VT & VA)  
MATTHEW J. SICKLER, P.E. (NY & PA)  
PATRICK J. HINES

Main Office  
33 Airport Center Drive  
Suite 202  
New Windsor, New York 12553

(845) 567-3100  
fax: (845) 567-3232  
e-mail: mheny@mhepc.com

Principal Emeritus:  
RICHARD D. McGOEY, P.E. (NY & PA)  
WILLIAM J. HAUSER, P.E. (NY, NJ & PA)

## TOWN OF NEW WINDSOR LANDFILL

### PERIODIC REVIEW REPORT

Site # 336019

Orange County, New York

**CLIENT:**

Town of New Windsor  
555 Union Avenue  
New Windsor, NY 12553

**PREPARED BY:**

McGoey, Hauser and Edsall  
Consulting Engineers, D.P.C.  
33 Airport Center, Suite 202  
New Windsor, NY 12553

Addition to this Document is a  
Violation of Section 7209(2)  
of the New York State Education Law.

DATE: 1 September 2016  
JOB #: 94-116



## **TABLE OF CONTENTS**

	<b><u>PAGE</u></b>
I. EXECUTIVE SUMMARY .....	1
II. SITE OVERVIEW .....	1
III. EVALUATE REMEDY PERFORMANCE EFFECTIVENESS & PROTECTIVENESS .....	2
IV. IC/EC PLAN COMPLIANCE .....	5
V. CONCLUSION AND RECOMMENDATIONS .....	7

## **ATTACHMENTS**

ATTACHMENT 1: SITE LOCATION MAP

ATTACHMENT 2: SITE SPECIFIC MAP

ATTACHMENT 3: NEW WINDSOR LANDFILL 2<sup>ND</sup> QUARTER REPORT

ATTACHMENT 4: GRAPHS FOR DRINKING WATER STANDARDS

ATTACHMENT 5: 3 YEARS OF QUARTERLY REPORTS



## I. EXECUTIVE SUMMARY

The Town of New Windsor Landfill site is located in the Town of New Windsor, Orange County, New York and is identified as Section 3, Block 1, Lot 2 on the Town of New Windsor Tax Maps. The site is a 14.7+/- acre parcel of property bounded by the Air National Guard Property to the north a privately owned parcel, to the South Interstate 87 to the east and a vacant parcel of property privately owned to the west.

The Town of New Windsor Landfill was operated by the Town from approximately 1962 till 1978 reportedly accepting both municipal and industrial waste. Available information indicates this site received up to 3,000 drums of paint sludge and 6,000 drums from a drum recycling company. Other local industries reputedly used the site to dispose of industrial materials. The Phase I investigation was undertaken in 1983. A Phase II study was completed by a New York State DEC contractor in 1985. The remedial investigation was initiated by the Town of New Windsor in 1990, and a Landfill closure plan and construction activity proceeded during 1993 resulting in the closure of the landfill. The site has been reclassified from a 2A classification to a 4 classification by the NYSDEC. Operation and monitoring of the site have been undertaken since completion of the landfill cap. Ongoing operation and maintenance is undertaken by the Town of New Windsor and contract personnel. The current engineering and institutional controls at the landfill site are functioning as designed with no proposed changes. No non compliance activities and no significant issues have been identified during this monitoring period. Based on the ongoing activities on the site no additional monitoring of the landfill site is required.

## II. SITE OVERVIEW

The landfill site is located just north of the intersection of NYS Route 207 and the NYS Thruway overpass. The landfill site is located at the terminus of Silver Stream Road. Silver Stream Road is a Town owned and maintained roadway which ends at the landfill access gate. The site is completely fenced to restrict access. The site is located on a 14.7+/- acre parcel of property. **Attachment 1** to this report contains a location map and of the site in relation to the Town of New Windsor. **Attachment 2** to this map contains the site specific map identifying various features. As identified in the Executive Summary the site was operated as a municipal landfill from approximately 1962 through 1978 accepting both municipal and industrial waste from the Town of New Windsor and surrounding areas. Initial investigations of the landfill identified a quantity of drummed waste from various industrial users in the vicinity of the Town of New Windsor. During the landfill capping program approximately 16,000 cubic yards of waste material was excavated from the Air National Guard property north of the landfill site and incorporated into the final grading prior to capping of the landfill.

The landfill was capped with a low density polyethylene membrane as well as a drainage layer, a gas venting layer and a 2 foot clay cap over the low density membrane. A gas vent system was incorporated in to the original design which continues to function allowing any potential gas build up below the cap to vent thru the gas venting system. Flame arresters are incorporated into the gas vent system.

A leachate collection system has been operating at the site collecting leachate from the northern and western portions of the cap, discharging via gravity to an onsite leachate collection pump station. The pump station discharges leachate to the Town of New Windsor Sanitary Sewer Collection System for treatment at the town owned sewage treatment facility. Ongoing monitoring of the leachate has occurred since 1993. The site has operated in compliance with discharge permits issued by the Town of New Windsor sewage treatment plant during this monitoring period.

Institutional controls have been implemented via a declaration of covenants and restrictions filed in the Orange County Clerk's office. No users of ground water are located within the vicinity of the Town of New Windsor landfill. Any nearby residence of businesses are served by the Town of New Windsor's municipal water system. No residences are located within 750 feet of any boundary of the landfill site.

### III. EVALUATE REMEDY PERFORMANCE EFFECTIVENESS AND PROTECTIVENESS

The Town of New Windsor currently monitors groundwater and surface water at the landfill site. The Town of New Windsor utilizes the services of a contract laboratory for sample collection, analysis and reporting. These sample data packages are submitted to the Town's consulting engineer for evaluation and record keeping. The site management plan requires monitoring of 14 groundwater monitoring wells and 2 surface water samples. The groundwater monitoring wells are monitored quarterly or annually based on the site management plan, most recently modified in 2010. Monitoring wells 6D, 6S, 9S and 11S are monitored quarterly for part 360 baseline with VOC's. The remaining monitoring wells 1D, 1S, 3D, 3S, 4D, 4S, 7D, 8D, 10D and 10S are monitored annually for part 360 baseline with VOC's. Surface water samples 1 and 2 are monitored annually for part 360 baseline with VOC's.

The leachate discharged from the landfill site is sampled quarterly based on a pre treatment permit issued by the Town of New Windsor's contract operator. Town of New Windsor contract personnel monitor the functioning of the leachate collection pump station daily. Gas vent monitoring is performed during sample events by the contract laboratory on a quarterly basis.

Town Highway Department personnel review the site periodically, including periodic mowing of the landfill cap to prevent woody vegetation from growing. Currently the landfill cap is mowed twice annually to maintain the landfill cap as a grass field. Security at the landfill site is provided by a 6 foot fence completely surrounding the perimeter of the landfill cap. The fence is secured by locks owned by the Town of New Windsor and the publicly owned utility company who must read the electric meter on a periodic basis.

**Attachment 3** to this report contains the Town of New Windsor Landfill 2016 2<sup>nd</sup> Quarter Report. This report identifies compliance with the monitoring requirements of the groundwater and surface water monitoring locations consistent with the site management plan. **Attachment 3** identifies 5 years worth of data for the monitoring wells which are sampled annually and 2 years worth of data for those which are sampled quarterly.

Many of the monitoring wells on the site exceed drinking water standards for iron, manganese and sodium. The iron and manganese exceedences can be attributed to local groundwater conditions which often exceed drinking water standards for these parameters.

The following will provide a brief review of each of the monitoring wells and any issues associated with the groundwater quality in the monitoring wells.

MW-1S: This shallow monitoring well is located near the entrance to the landfill. This monitoring well typically exceeds drinking water standards for sodium, iron and color. Recent levels of these parameters are on an upward trend, however it is noted that the most recent sample for 2<sup>nd</sup> quarter 2016 had a turbidity of 4,000 NTU's. This high turbidity causes levels of the iron and sodium to be elevated. It is noted that chloride levels are slightly increased for the 2<sup>nd</sup> quarter 2016. Chloride levels at the New Windsor landfill site are associated with ice control activities on the adjoining NYS Thruway corridor. No VOC's have been recorded in this shallow monitoring well.

MW-1D: Exhibits high levels of sodium, manganese and iron. These levels can be attributed to parent bedrock geology. This deep up gradient monitoring well remains consistent with levels of the 3 parameters identified. It is noted that no VOC's have been recorded in the monitoring well during the 5 year period identified on the spreadsheet.

MW-3D: This well has exceedences for drinking water standards for iron, manganese and sodium. These levels are lower than those which are experienced in other monitoring wells on the site. In 2013 an exceedance for chromium, and in 2014 and exceedance for the drinking water parameter for color were also noted. Manganese levels are varied in this monitoring well to below drinking water standards to a high of 470 ug/l. Sodium levels in this monitoring well are approximately double the drinking water standard. All other parameters are below drinking water standards for groundwater. No VOC's have been recorded for the last 5 years for this monitoring well.

MW-3S: This well is located on the northerly most portion of the landfill site on the boundary of the Air National Guard property. This monitoring well is installed at approximately the same depth and strata as MW9-S located south of this well on Air National Guard property.

MW-4D: This deep monitoring well located along the easterly portion of the site north of the landfill cap, typically meets drinking water standards for all parameters with the exception of iron. During the 2016 2<sup>nd</sup> quarter event the monitoring well met drinking water standards for all parameters sampled for. No volatile organic compounds have been identified in this monitoring well.

MW-4S: This well typically exceeds drinking water standards for sodium, manganese, iron, color and chloride. Issues regarding exceedences for chloride have to do with the proximity of this monitoring well to the NYS Thruway corridor. Shallow monitoring wells along the eastern portion of the site are impacted by ice control activities on the NYS Thruway. This monitoring well experienced exceedences for drinking

water standards for lead in 2011 and 2014. 2015 sample identifies compliance with the drinking water standard for lead.

MW-6D: This is an up gradient deep monitoring well. Levels of sodium are typically twice the drinking water standard in this monitoring well. Levels of sodium are consistent throughout the two years of data presented in the charts. An occasional high pH reading and levels of iron have been recorded. No volatile organic compounds have been recorded in this monitoring well.

MW-6S: This monitoring well experiences elevated levels of sodium. Levels of sodium are consistent in the monitoring well ranging from a low of 126,000 to a high of 1,030,000 ug/L. This monitoring well periodically exceeds the drinking water standard for iron, chromium and color. Chloride levels in this monitoring well also are high associated with the proximity to the NYS Thruway. Turbidity during the 2016 2<sup>nd</sup> quarter monitoring event was excessive at 4,000 ntu's. No volatile organic compounds have been identified in this monitoring well.

MW-7D: This deep monitoring well is located off site east of the NYS Thruway. This monitoring well typically exhibits slight exceedance for the drinking water standard for sodium and an occasional exceedance for iron has been noted. This well has not exhibited volatile organic compounds in the 5 years data presented.

MW-8D: This monitoring well is located on the western portion of the site in the vicinity of the leachate collection pump station. This deep monitoring well exhibits elevated levels of iron which appear on a slight downward trend. This deep monitoring well does not exhibit elevated levels of a sodium or manganese associated with other deep monitoring wells in the proximity of the landfill. No VOC's have been recorded.

MW-9S: This monitoring well is installed off site north of the landfill site on Air National Guard property which previously contained fill material which was removed during landfill cap process. Approximately 16,000 cubic yards of material was excavated from the Air National Guard property and incorporated under the final grades prior to capping. This monitoring well typically exhibits exceedances for iron, manganese and sodium. This monitoring well exceeds the drinking water standard for Boron consistently with ranges from approximately 120-200 ug/l. Monitoring well 9S is the only monitoring well on the landfill site which exhibits any recorded VOC's. Levels of VOC's have been reduced over the 2 years of data presented. Currently acetone has been identified in this monitoring well. It is believed this acetone level is a lab contaminant and not associated with the landfill site itself. No acetone has previously been identified in the 2 years data presented. The VOC levels encountered at this monitoring well are slightly above drinking water standard for cumulative VOC's in ground water. MW9-S having been constructed within an area which previously contained fill is impacted by the location of the monitoring well. Levels of VOC's recorded have been on a reducing trend over time.



MW-10D: This monitoring well is located along the western central portion of the landfill site. Monitoring well 10-D experiences slightly elevated levels of iron during some monitoring events. This monitoring well being a deep, upgradient monitoring well exhibits no impacts associated with the landfill site. No VOC's have been identified for the 5 year period presented.

MW-10S: This monitoring well is located in close proximity to 10-D. This monitoring well is an upgradient shallow monitoring well. The well exhibits slightly elevated levels of manganese and elevated levels of iron associated with surrounding bedrock geology. No volatile organic compounds are identified during this monitoring.

MW-11S: This monitoring well is located upgradient of the landfill site, west of the access drive. This monitoring well exhibits elevated levels of iron and manganese as well as sodium, similar to other monitoring wells. These parameters can be attributed to area bedrock and the high levels of turbidity experienced during sampling of this monitoring well. Elevated levels of turbidity indicated that sediment is incorporated into the samples which will cause elevated levels of the three (3) parameters identified. This monitoring well has had excursions for lead in the past which are associated with elevated levels of turbidity in the samples. No VOC's have been encountered in this monitoring well during the monitoring period.

Surface Water Sample SW1: SW1 is located north of the capped landfill site at the Air Guard/Town of New Windsor property line at a former sediment pond facility utilized during construction of the landfill cap. Surface water sample #1 has identified elevated levels of iron, manganese and sodium similar to shallow monitoring wells throughout the site. Surface water sample #1 has exhibited slightly elevated levels of acetone during the 2<sup>nd</sup> quarter 2016 and 3<sup>rd</sup> quarter 2014 monitoring events. It is not believed this parameter is discharging from the New Windsor landfill site.

Surface Water Sample SW2: SW2 is located at a culvert on the west side of the NYS Thruway approximately 1,400 feet north of the landfill site. This surface water sample exhibits elevated levels of iron, manganese and sodium. No VOC's have been recorded in this monitoring well since 2009. Since 2009 this site has been dry, however 4 years of data, 2013, 2014, 2015 and 2016 are currently presented.

**Attachment 4** to this report contains graphical information pertaining to any exceedances of drinking water standards for the parameters sampled. This graphical information is tracked for identifying trends in any parameter considered significant.

#### IV. IC/EC PLAN COMPLIANCE

- A. Institutional Controls: Institutional controls have been implemented by the Town of New Windsor to restrict utilization of ground water and land use on the project site. Institutional controls have remained in effect and no ground water users are located within the vicinity of the

landfill site. The Town of New Windsor currently does not have plans to utilize the landfill site. The site is currently in a fenced, vacant field condition.

**B. Engineering Controls:**

1) Fenced Security: The landfill site is fenced with a 6 foot high fence with access control via locked gates. Locks are restricted and only the following personnel are permitted to enter the site:

- Camo Pollution Control: Contract operators for leachate pump station.
- EnviroTest: Contract laboratory.
- MH&E: Town Engineers.
- Central Hudson Gas & Electric: for meter reading activities.
- Town Highway Dept./Recreation Dept. Personnel

The security fencing remains in place and functioning as designed.

2) Leachate Pump Station: A leachate pump station has been constructed on the site which collects leachate from the northern and westerly portions of the landfill site. Daily monitoring of the leachate pump station is performed by Camo Pollution Control, the Town's Sanitary Sewer operator. Quarterly samples in compliance with a pre-treatment permit are obtained and submitted to the Town of New Windsor Sewage Treatment Plant for compliance with the industrial pre-treatment program. **Attachment 5** to this report contains 3 years of quarterly reports identifying compliance with the Town of New Windsor's pre-treatment permit. No excursions of the pre-treatment permit have been identified during the monitoring.

3) Gas Vent Monitoring System: The landfill site has been equipped with a gas vent monitoring system. These gas vents are periodically monitored by the contract laboratory and Town personnel to assure ongoing function of the gas venting system. No issues with the gas venting system have been identified during this monitoring period.

4) Landfill Cap: The landfill cap consists of a 6 inch topsoil layer, a 24 inch barrier protective layer, a drainage layer (8 ounce geo textile geo net, 8 ounce geo textile membrane), a geo textile low permeability barrier, 18 inches of cover, a gas collection layer, (8 ounce geo textile geo net, 8 ounce geo textile) and soil cover over waste. This landfill cap serves to protect the waste mass from intrusion of surface water while allowing any gas to discharge via the gas vents installed at the site. The landfill cap is maintained in a grassed field condition thru periodic mowing by Town forces.

All IC/EC requirements of the initial landfill closure continue to function as designed. Protective measures incorporated into the design including security, engineering controls and long term operation and maintenance continue at the project site to assure functioning of the landfill remediation. No changes to the institutional and engineering controls are required.

## **V. OPERATION AND MAINTENANCE**

The landfill site is subject to periodic mowing in order to maintain the project site as a grassed lawn condition. Town of New Windsor Highway Department personnel perform periodic mowing at least twice annually in order to maintain the site in the grassed lawn condition and prevent the growth of woody vegetation on the landfill cap. The town has completed this twice annual mowing since closure of the landfill in the early 1990's. No change to the maintenance schedule is anticipated.

**Pump Station Operation and Maintenance:** Town of New Windsor contract operators, Camo Pollution Control field evaluate the pump station on a once daily basis. Camo staff access the controls, record pump run time and generally inspect the pump station operation daily. Daily monitoring reports are recorded and maintained at the Sewage Treatment Plant for the on site pump station. Quarterly sampling of the leachate is performed in compliance with the Town of New Windsor's pre-treatment discharge permit. No exceedances for any parameter have been identified during this monitoring period.

Town of New Windsor Highway personnel in conjunction with the Town Engineer's office periodically field review the landfill site with regard to general operation and maintenance of the site. Field review of conditions at the landfill site drainage structures, gas vent monitoring, security fencing, locks, etc. are undertaken in compliance with the site management plan. No deficiencies on the site have been noted during the monitoring period. Continued periodic inspections will be undertaken during the upcoming monitoring period.

Based on a review of the operation and maintenance of the landfill site no changes to the O & M plan have been identified. Continued operation and maintenance of the landfill in its current state will assure that the site operates as designed. The site has been in a relatively static condition for several decades. Ongoing monitoring and maintenance of the site will continue based on the current site management plan.

## **VI. CONCLUSION AND RECOMMENDATIONS**

Based on the long term operation and maintenance of the Town of New Windsor landfill site no changes to site management plan have been recommended. Continued operation and maintenance of the facility at the current level and intensity will maintain the function of all engineered controls. A review of the groundwater and surface water monitoring identifies no significant changes or impacts from the project site. It is noted that only one monitoring well exhibits VOC's during many years of monitoring. Based on a review of the data we would recommend that monitoring well 6D, 6S and 11S have the sampling changed from quarterly to annually consistent with other monitoring wells on the site.

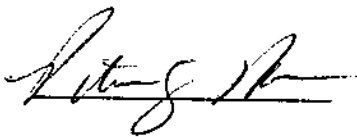
Monitoring well 9S is recommended to be continued quarterly sampled with VOC's in order to identify any trends in this monitoring well.

The institutional and engineering controls established at the New Windsor landfill site since the early 1990's are effectively mitigating the impacts associated with the former Class 2A landfill. No additional IC or EC controls are required.

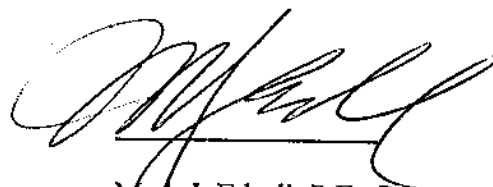
We continue to recommend the submission of periodic review reports on a 3 year basis as currently required. No changes to the 3 year period are recommended.

Respectfully submitted,

**McGoey, Hauser and Edsall**  
**Consulting Engineers, D.P.C.**



Patrick J. Hines  
Principal



Mark J. Edsall, P.E., P.P.  
Principal/C.E.O.

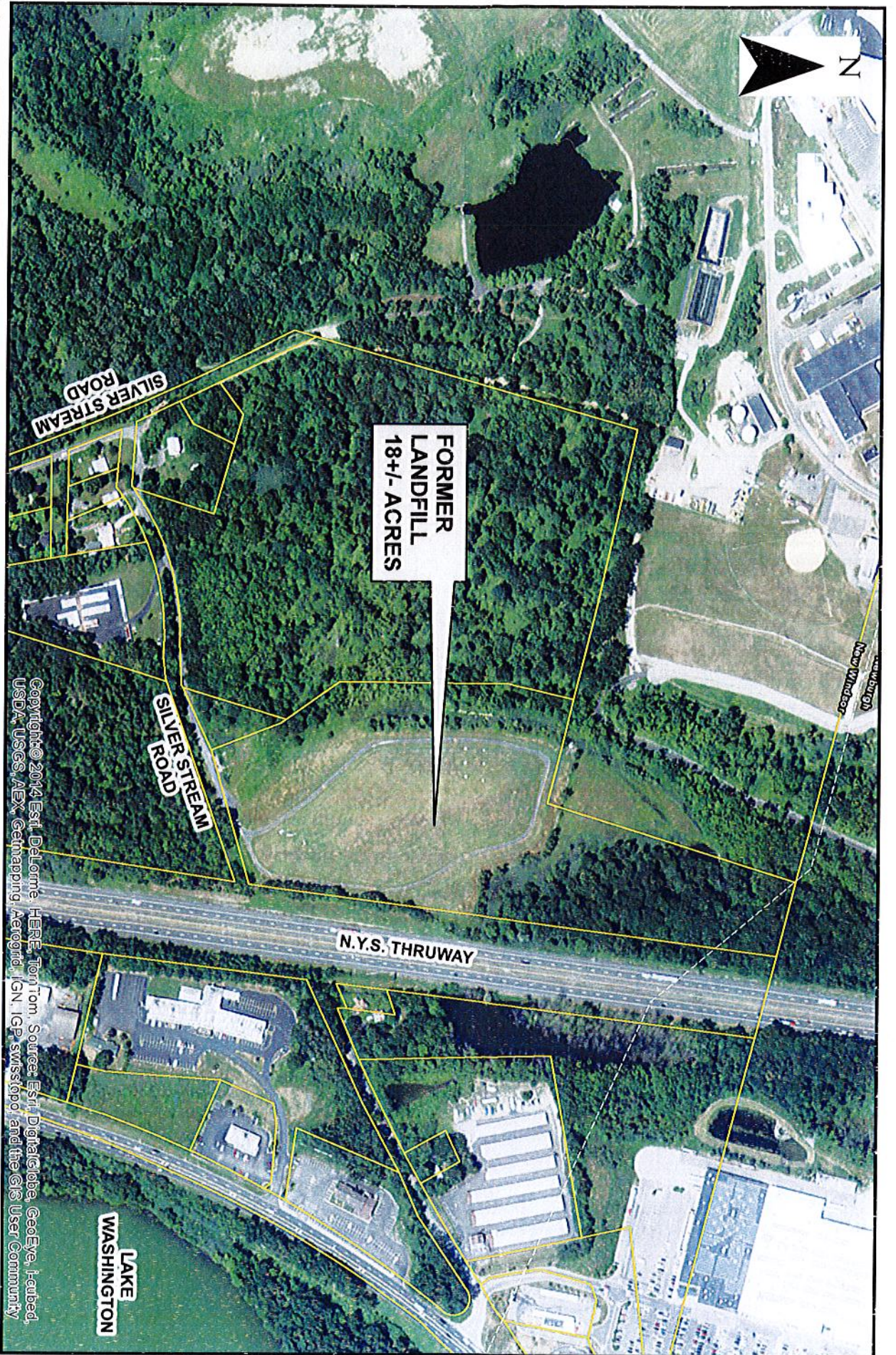
# **ATTACHMENTS**



# **ATTACHMENT 1**







FORMER  
LANDFILL  
18+/- ACRES

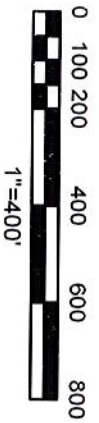
SILVER STREAM  
ROAD

SILVER STREAM  
ROAD

N.Y.S. THRUWAY

LAKE  
WASHINGTON

Copyright © 2014 Esri, Delorme, HERE, TomTom, SourceFirst, DeLorme, GeoEye, iSat, Swire, USDA, USGS, AEX, Geomatics, Aergrid, IGN, IGP, swisstopo, and the GIS User Community



**TOWN OF NEW WINDSOR**  
**FORMER LANDFILL SITE**

PREPARED BY



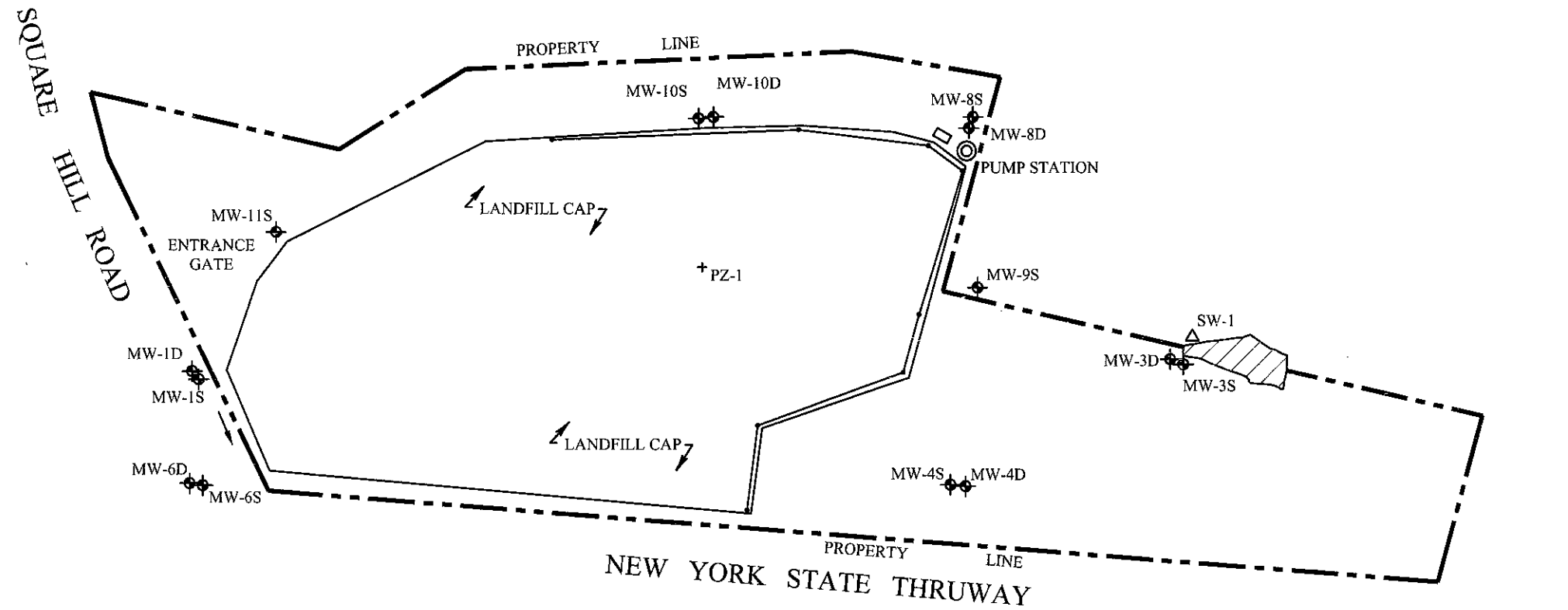
5-14-2015



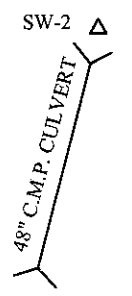


# **ATTACHMENT 2**



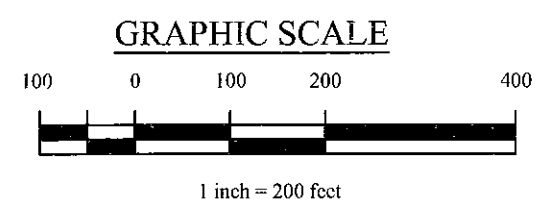


WELL	ELEVATION TOP OF WELL CASING (FEET)	DEPTH (FEET)
MW-1S	358.44	21.5
MW-1D	358.78	30.0
MW-3S	335.97	14.5
MW-3D	338.29	28.0
MW-4S	337.71	14.0
MW-4D	338.30	38.0
MW-6S	357.20	23.5
MW-6D	358.01	93.0
MW-7D	351.23	95.0
MW-8S	340.20	15.0
MW-8D	339.15	45.0
MW-9S	339.29	14.5
MW-10S	339.80	15.0
MW-10D	339.16	60.0
MW-11S	359.64	15.0
PZ-1	352.43	21.5
LCMH-2	344.89	12.42
LCMH-4A	341.88	8.85



**SITE PLAN**  
SCALE: 1" = 200'

- LEGEND:**
- ◆ MW- MONITORING WELL
  - + PZ- PIEZOMETER
  - △ SW- SURFACE WATER SAMPLE LOCATION



Unauthorized addition or alteration of this plan is a violation of Section 7209(2) of the New York State Education Law.

**MHEP** **McGOEY, HAUSER and EDSALL**  
**CONSULTING ENGINEERS, D.P.C.**  
 33 Airport Center Drive, New Windsor, New York 12553 (845) 587-3100  
 111 Wheatfield Drive, Suite 1, Miford, Pennsylvania 19337 (570) 296-2785

Plan for:  
**TOWN OF NEW WINDSOR LANDFILL**  
 Town of New Windsor, Orange County, New York

Revision	Date	Description

Design: P.J.H.	<b>SITE PLAN</b>	Sheet: <b>SP-1</b>
Drawn: D.J.S.		
Checked: M.J.E.		
Scale: AS NOTED		
Date: 24 May 2016		
Job No: 94-116		Of: file: SITE PLAN



# **ATTACHMENT 3**





**NEW WINDSOR  
LANDFILL  
2016 – 2nd QUARTER**



In accordance with the approved Work Plan:

MW 8S – Bent casing, cannot be sampled

SW1, SW2 –Part 360 Baseline with VOCs - sampled annually

6D, 6S, 9S, 11S – Part 360 Baseline with VOCs sample quarterly

1D, 1S, 3D, 3S, 4D, 4S, 7D, 8D, 10D, 10S – Part 360 Baseline with VOCs sample annually

## **New Windsor Landfill**

### **Summary Results - Exceedances**

#### **2016 –2nd Quarter**

MW-1D - Color, Iron, Manganese, Sodium

MW-1S – Chloride, Color, Iron, Sodium

MW-3D – Iron, Manganese, Sodium

MW-3S – Color, Iron, Manganese, Sodium

MW-4D – N/A

MW-4S – Chloride, Color, Iron, Manganese, Sodium, Acetone

MW-6D – Sodium

MW-6S – Chloride, Chromium, Color, Nickel, Iron, Sodium

MW-7D – Color, Iron, Sodium

MW-8D - Iron

MW-9S – Boron, Color, Iron, Manganese, Sodium, Acetone

MW-10D - Iron

MW-10S – Color, Iron, Manganese

MW-11S – Color, Iron, Manganese, Sodium

SW1 – Color, Iron, Manganese, Sodium, Acetone

SW2 – Color, Iron, Manganese, Sodium

#### **Not Sampled**

MW 8S – Bent casing

# MW-1D

PARAMETER	UNIT	STANDARD	2012	2013	2014	2015	2016
			2nd Quarter	2nd Quarter	3rd Quarter	2nd Quarter	2nd Quarter
Alkalinity (as CaCO <sub>3</sub> )	MG/L	N.S.		346	309	311	322
Aluminum	UG/L	N.S.				540	220
Ammonia	MG/L	FEN OF T					
Antimony	UG/L	3					
Arsenic	UG/L	25					
BOD (5)	MG/L	N.S.					18.2
BOD Time of Analysis)							
Barium	UG/L	1000					
Beryllium	UG/L	4					
Boron	UG/L	10					
Bromide	UG/L	10					
Cadmium	UG/L	5					
Calcium	UG/L	N.S.		161000	141000	150000	133000
Chemical Oxygen Demand	MG/L						
Chloride	MG/L	250		183	190	165	180
Chromium	UG/L	50		23			14
Cobalt	UG/L						
Color (Pt/Co. Units)	PT/CO	15		20	20	25	40
Copper	UG/L	200					
Cyanide, Total	UG/L	200					
Dissolved Oxygen							
eH (millivolts)		N.S.					
Field Observation							
Floater and sinkers (P/NP)							
Hardness (as CaCO <sub>3</sub> )				401	352	376	299
Hexavalent Chromium	UG/L	50					
Iron	UG/L	300		8000	880	1400	520
Lead	UG/L	15			5.6		
Magnesium	UG/L	35000		17900	14700	15700	15000
Manganese	UG/L	300		840	530	700	470
Mercury	UG/L	0.7					
Nickel	UG/L	100					
Nitrate	MG/L	10			0.65		
pH (Std.)		6.5-8.5		7.07	7.5	7.29	
Potassium	UG/L	N.S.					
Selenium	UG/L	10					
Silver	UG/L	50					
Sodium	UG/L	20000		78500	66300	76900	80500
Specific Conductivity		N.S.		1140	693	600	
Static Water Level (Ft.)							
Sulfate	MG/L	250		37	41	37.6	38.5
Temperature (C)	MG/L	N.S.		11.9	14.6	12.5	
Thallium	UG/L	2					
Total Dissolved Solids	MG/L			766	816	734	758
Total Hardness	MG/L			475	412	440	355
Total Kjeldahl Nitrogen	MG/L						
Total Organic Carbon	MG/L			2.8	4.18	1.7	2.9
Total Phenols	UG/L			0.014			
Turbidity (NUT)	NTU	N.S.		13	7.33	27.65	24.3
Vanadium	UG/L						
Zinc	UG/L	5000		32	24	26	

VOC							
Acetone	UG/L	5					

Beryllium, Cadmium, Cyanide, Thallium, Chloride, Iron, Manganese, Sodium, Sulfate, Zinc and Color standards - <http://www.health.state.ny.us/environmental/water/drinking/part5/tables.htm#tab>  
 Antimony, Arsenic, Barium, Chromium, Copper, Mercury, Nickel, Selenium, Silver - 6 NYSRR Part 703

# MW-1S

PARAMETER	UNIT	STANDARD	2011	2013	2014	2015	2016
			2nd QUARTER	2nd QUARTER	3rd QUARTER	2nd QUARTER	2nd QUARTER
Alkalinity (as CaCO <sub>3</sub> )	MG/L	N.S.	221	189	188	265	222
Aluminum	UG/L	N.S.		980		2600	7000
Ammonia	MG/L	FEN OF T					
Antimony	UG/L	3					
Arsenic	UG/L	25					
BOD (5)	MG/L	N.S.	6				
BOD Time of Analysis)							
Barium	UG/L	1000					
Beryllium	UG/L	4					
Boron	UG/L	10					
Bromide	UG/L	10					
Cadmium	UG/L	5					
Calcium	UG/L	N.S.	76900	62100	54400	42400	45800
Chemical Oxygen Demand	MG/L		56.6	27.8		18.5	
Chloride	MG/L	250	190	125	127	108	265
Chromium	UG/L	50					11
Cobalt	UG/L						
Color (Pt/Co. Units)	PT/CO	15	20	25	30	30	75
Copper	UG/L	200			26	28	45
Cyanide, Total	UG/L	200					
Dissolved Oxygen							
eH (millivolts)		N.S.					
Field Observation							
Floater and sinkers (P/NP)							
Hardness (as CaCO <sub>3</sub> )			221	155	136	106	103
Hexavalent Chromium	UG/L	50					
Iron	UG/L	300	170	910	5700	2700	5600
Lead	UG/L	15			9.5	5.6	
Magnesium	UG/L	35000	6900	5900	6300		5600
Manganese	UG/L	300	190	150	100	57	140
Mercury	UG/L	0.7				0.22	
Nickel	UG/L	100					
Nitrate	MG/L	10					
pH (Std.)		6.5-8.5		6.68	7.47	6.98	
Potassium	UG/L	N.S.					
Selenium	UG/L	10					
Silver	UG/L	50					
Sodium	UG/L	20000	106000	84900	83500	145000	218000
Specific Conductivity		N.S.		750	526	5.07	
Static Water Level (Ft.)							
Sulfate	MG/L	250	23.8	14.1	22.7	19.8	
Temperature (C)	MG/L	N.S.		13.5	14.6	15.1	
Thallium	UG/L	2					
Total Dissolved Solids	MG/L		534	412	480	542	630
Total Hardness	MG/L		221	179	162	124	124
Total Kjeldahl Nitrogen	MG/L						
Total Organic Carbon	MG/L		5	3.6	5.27	6.9	9.7
Total Phenols	UG/L			0.037	0.01	0.011	
Turbidity (NUT)	NTU	N.S.	4.69	10.1	13.3	19.01	4000
Vanadium	UG/L						
Zinc	UG/L	5000		21	48	38	49

## VOC

Acetone	UG/L	5					
Methylene Chloride	UG/L	5					

Beryllium, Cadmium, Cyanide, Thallium, Chloride, Iron, Manganese, Sodium, Sulfate, Zinc and Color standards - <http://www.health.state.ny.us/environmental/water/drinking/parts/table>  
 Antimony, Arsenic, Barium, Chromium, Copper, Mercury, Nickel, Selenium, Silver - 6 NYSRR Part 703



# MW-3D

PARAMETER	UNIT	STANDARD	2011	2013	2014	2015	2016
			2nd QUARTER	2nd QUARTER	3rd QUARTER	2nd QUARTER	2nd QUARTER
Alkalinity (as CaCO <sub>3</sub> )	MG/L	N.S.	160	327	146	189	341
Aluminum	UG/L	N.S.		500			740
Ammonia	MG/L	FEN OF T		0.072			
Antimony	UG/L	3					
Arsenic	UG/L	25					
BOD (5)	MG/L	N.S.					
BOD Time of Analysis)							
Barium	UG/L	1000					
Beryllium	UG/L	4					
Boron	UG/L	10					
Bromide	UG/L	10					
Cadmium	UG/L	5					
Calcium	UG/L	N.S.	34100	106000	17700	52200	101000
Chemical Oxygen Demand	MG/L			54.7			
Chloride	MG/L	250	32	52.1	30.1	36	85
Chromium	UG/L	50	26	61	28	19	
Cobalt	UG/L						
Color (Pt/Co. Units)	PT/CO	15	2.5	10	50	10	10
Copper	UG/L	200					
Cyanide, Total	UG/L	200					
Dissolved Oxygen							
eH (millivolts)		N.S.					
Field Observation							
Floater and sinkers (P/NP)							
Hardness (as CaCO <sub>3</sub> )			85.2	264	44.1	130	226
Hexavalent Chromium	UG/L	50	0.022				
Iron	UG/L	300	300	990	930	740	660
Lead	UG/L	15			9	5.1	
Magnesium	UG/L	35000	15700	15600	14300	15000	14900
Manganese	UG/L	300	110	470	91	140	460
Mercury	UG/L	0.7					
Nickel	UG/L	100					
Nitrate	MG/L	10	0.35	0.13	1.1	1.2	
pH (Std.)		6.5-8.5			8.19	7.86	
Potassium	UG/L	N.S.					
Selenium	UG/L	10					
Silver	UG/L	50					
Sodium	UG/L	20000	36000	38800	37000	36200	43000
Specific Conductivity		N.S.			305	329	
Static Water Level (Ft.)							
Sulfate	MG/L	250	24.3	28.4	19.9	24.7	
Temperature (C)	MG/L	N.S.			18.6	17.1	
Thallium	UG/L	2					
Total Dissolved Solids	MG/L		238	386	244	318	500
Total Hardness	MG/L		150	328	103	192	282
Total Kjeldahl Nitrogen	MG/L						
Total Organic Carbon	MG/L		1.6	1.9	2.69	1.4	2.5
Total Phenols	UG/L						
Turbidity (NTU)	NTU	N.S.	1.73	19.2	19.2	6.76	20.8
Vanadium	UG/L						
Zinc	UG/L	5000					

## VOC

Acetone	UG/L	5				
Methylene Chloride	UG/L	5				

Beryllium, Cadmium, Cyanide, Thallium, Chloride, Iron, Manganese, Sodium, Sulfate, Zinc and Color standards - <http://www.health.state.ny.us/environmental/water/drinking/part5/tables.htm#table1>  
 Antimony, Arsenic, Barium, Chromium, Copper, Mercury, Nickel, Selenium, Silver - 6 NYSRR Part 703

# MW-3S

PARAMETER	UNIT	STANDARD	2011	2013	2014	2015	2016
			2nd QUARTER	2nd QUARTER	3rd QUARTER	2nd QUARTER	2nd QUARTER
Alkalinity (as CaCO <sub>3</sub> )	MG/L	N.S.	321	352	341	347	337
Aluminum	UG/L	N.S.	17700	29500		12400	30400
Ammonia	MG/L	FEN OF T		0.2			
Antimony	UG/L	3					
Arsenic	UG/L	25		17			
BOD (5)	MG/L	N.S.					
BOD Time of Analysis)							
Barium	UG/L	1000	240	300	220	230	340
Beryllium	UG/L	4					
Boron	UG/L	10					
Bromide	UG/L	10					
Cadmium	UG/L	5					115000
Calcium	UG/L	N.S.	129000	126000	112000	130000	
Chemical Oxygen Demand	MG/L		98.1	96.2		37.8	
Chloride	MG/L	250	99.9	46.3	47.6	50	55
Chromium	UG/L	50	29	42	16	26	36
Cobalt	UG/L						
Coior (Pt/Co. Units)	PT/CO	15	10	15	75	25	250
Copper	UG/L	200	47	59			37
Cyanide, Total	UG/L	200					
Dissolved Oxygen							
eH (millivolts)		N.S.					
Field Observation							
Floaters and sinkers (P/NP)							
Hardness (as CaCO <sub>3</sub> )			323	315	279	325	258
Hexavalent Chromium	UG/L	50					
Iron	UG/L	300	33200	45100	17400	24400	25800
Lead	UG/L	15	22	29	67	12	
Magnesium	UG/L	35000	23200	25900	17100	19700	20800
Manganese	UG/L	300	1900	2100	1400	1400	1300
Mercury	UG/L	0.7					
Nickel	UG/L	100		47			
Nitrate	MG/L	10			0.19		
pH (Std.)		6.5-8.5		7.58	7.89	7.6	
Potassium	UG/L	N.S.	7200	6700			11000
Selenium	UG/L	10					
Silver	UG/L	50					
Sodium	UG/L	20000	35900	38400	33200	40200	41600
Specific Conductivity		N.S.		760	500	456	
Static Water Level (Ft.)							
Sulfate	MG/L	250	31.1	33.4	33.5	33.2	
Temperature (C)	MG/L	N.S.		12.1	13.3	12	
Thallium	UG/L	2					
Total Dissolved Solids	MG/L		438	452	564	544	524
Total Hardness	MG/L		418	422	350	406	335
Total Kjeldahl Nitrogen	MG/L		2.2	1.3			1.7
Total Organic Carbon	MG/L		2.7	3.1	3.86	1.6	3
Total Phenols	UG/L						
Turbidity (NUT)	NTU	N.S.	583	635	151.2	77.36	4000
Vanadium	UG/L						70
Zinc	UG/L	5000	110	140	99	61	100

## VOC

Acetone	UG/L	5				
Methylene Chloride	UG/L	5				
m,p-Xylene	UG/L	5				
Carbon Disulfide	UG/L	5				



# MW-4D

PARAMETER	UNIT	STANDARD	2011	2013	2014	2015	2016
			2nd QUARTER	2nd QUARTER	3rd QUARTER	2nd QUARTER	2nd QUARTER
Alkalinity (as CaCO <sub>3</sub> )	MG/L	N.S.	179	124	121	114	112
Aluminum	UG/L	N.S.					
Ammonia	MG/L	FEN OF T		1.9			
Antimony	UG/L	3					
Arsenic	UG/L	25		12			
BOD (5)	MG/L	N.S.					
BOD Time of Analysis)							
Barium	UG/L	1000					
Beryllium	UG/L	4					
Boron	UG/L	10					
Bromide	UG/L	10					
Cadmium	UG/L	5					
Calcium	UG/L	N.S.	32900	38700	24300	29100	20400
Chemical Oxygen Demand	MG/L		41.8	44.9			
Chloride	MG/L	250		5.8		8	
Chromium	UG/L	50	13		15	12	17
Cobalt	UG/L						
Color (Pt/Co. Units)	PT/CO	15	2.5	25	15	15	5
Copper	UG/L	200					
Cyanide, Total	UG/L	200					
Dissolved Oxygen							
eH (millivolts)		N.S.					
Field Observation							
Floater and sinkers (P/NP)							
Hardness (as CaCO <sub>3</sub> )			82.1	96.6	60.7	72.6	45.9
Hexavalent Chromium	UG/L	50	0.01				
Iron	UG/L	300	470	630	360	310	83
Lead	UG/L	15			6	5.9	
Magnesium	UG/L	35000	10800	10200	10200	10200	11400
Manganese	UG/L	300	51	32	74	58	
Mercury	UG/L	0.7					
Nickel	UG/L	100					
Nitrate	MG/L	10	1.4	0.23	1.4	1.5	1.6
pH (Std.)		6.5-8.5		7.65	8.31	8.16	
Potassium	UG/L	N.S.					
Selenium	UG/L	10					
Silver	UG/L	50					
Sodium	UG/L	20000	7800	8200	8600	8700	10400
Specific Conductivity		N.S.		262	205	211	
Static Water Level (Ft.)							
Sulfate	MG/L	250	7.1	8	6.9	7.8	6
Temperature (C)	MG/L	N.S.		14.9	16.6	14.5	
Thallium	UG/L	2					
Total Dissolved Solids	MG/L		144	94	220	168	184
Total Hardness	MG/L		127	139	103	115	88
Total Kjeldahl Nitrogen	MG/L			2.5			
Total Organic Carbon	MG/L		2		2.35	1.1	1.1
Total Phenols	UG/L						
Turbidity (NUT)	NTU	N.S.	3.02	2.54	9.25	4.75	3.52
Vanadium	UG/L						
Zinc	UG/L	5000				27	

## VOC

Acetone	UG/L	5				
Methylene Chloride	UG/L	5				

Beryllium, Cadmium, Cyanide, Thallium, Chloride, Iron, Manganese, Sodium, Sulfate, Zinc and Color standards - <http://www.health.state.ny.us/environmental/water/drinking/part5/tables.htm#table1>  
 Antimony, Arsenic, Barium, Chromium, Copper, Mercury, Nickel, Selenium, Silver - 6 NYSRR Part 703

MW-4S			2011	2013	2014	2015	2016
PARAMETER	UNIT	STANDARD	2nd QUARTER	2nd QUARTER	3rd QUARTER	2nd QUARTER	2nd QUARTER
Alkalinity (as CaCO <sub>3</sub> )	MG/L	N.S.	130	250	212	196	192
Aluminum	UG/L	N.S.	14800	860		5500	20700
Ammonia	MG/L	FEN OF T	3.9	5.4			6.3
Antimony	UG/L	3					
Arsenic	UG/L	25					
BOD (5)	MG/L	N.S.	27.7			9	111
BOD Time of Analysis)							
Barium	UG/L	1000	210		210		
Beryllium	UG/L	4					
Boron	UG/L	10					
Bromide	UG/L	10					
Cadmium	UG/L	5					
Calcium	UG/L	N.S.	113000	103000	101000	88200	103000
Chemical Oxygen Demand	MG/L		149	113		79.2	
Chloride	MG/L	250	500	309	359	330	370
Chromium	UG/L	50			10		
Cobalt	UG/L						
Color (Pt/Co. Units)	PT/CO	15	75	150	750	500	3750
Copper	UG/L	200					27
Cyanide, Total	UG/L	200					
Dissolved Oxygen							
eH (millivolts)		N.S.					
Field Observation							
Floaters and sinkers (P/NP)							
Hardness (as CaCO <sub>3</sub> )			281	257	253	220	232
Hexavalent Chromium	UG/L	50	0.059				
Iron	UG/L	300	283000	36200	57700	91500	120000
Lead	UG/L	15	39		24	10	
Magnesium	UG/L	35000	12600	10500	11500	8800	12400
Manganese	UG/L	300	520	320	310	290	420
Mercury	UG/L	0.7					
Nickel	UG/L	100					
Nitrate	MG/L	10	0.42	0.28			
pH (Std.)		6.5-8.5		6.77	7.14	6.81	
Potassium	UG/L	N.S.					
Selenium	UG/L	10					
Silver	UG/L	50					
Sodium	UG/L	20000	269000	158000	135000	230000	177000
Specific Conductivity		N.S.		1293	853	758	
Static Water Level (Ft.)							
Sulfate	MG/L	250					
Temperature (C)	MG/L	N.S.		13.2	14.5	13.7	
Thallium	UG/L	2					
Total Dissolved Solids	MG/L		1060	844	1060	962	978
Total Hardness	MG/L		333	301	300	256	278
Total Kjeldahl Nitrogen	MG/L		8.2	7.2	7.6	3.7	6.5
Total Organic Carbon	MG/L		29.7	21.1	11.7	25.3	20
Total Phenols	UG/L						
Turbidity (NUT)	NTU	N.S.	3150	57.6	485.4	331.4	4000
Vanadium	UG/L						
Zinc	UG/L	5000	48		47	23	42

### VOC

Acetone	UG/L	5					6.9
Methylene Chloride	UG/L	5					
p-Isopropyltoluene	UG/L	5					
Tetrachloroethane	UG/L	5					

Beryllium, Cadmium, Cyanide, Thallium, Chloride, Iron, Manganese, Sodium, Sulfate, Zinc and Color standards - <http://www.health.state.ny.us/environmental/water/drinking/part5/tables.htm#table1>  
 Antimony, Arsenic, Barium, Chromium, Copper, Mercury, Nickel, Selenium, Silver - 6 NYSRR Part 703



MW-6D

PARAMETER	UNIT	STANDARD	2014	2014	2015	2015	2015	2015	2016	2016
			3rd Quarter	4th Quarter	1st Quarter	2nd Quarter	3rd Quarter	4th Quarter	1st Quarter	2nd Quarter
Alkalinity (as CaCO <sub>3</sub> )	MG/L	N.S.	146	150	145	152	158	178	169	115
Aluminum	UG/L	N.S.						95		
Ammonia	MG/L	FEN OF T								
Antimony	UG/L	3								
Arsenic	UG/L	25						4		
BOD (5)	MG/L	N.S.								
BOD Time of Analysis)										
Barium	UG/L	1000						29	29	
Beryllium	UG/L	4						0.24		
Boron	UG/L	10						29	18	
Bromide	UG/L	10								
Cadmium	UG/L	5							0.43	
Calcium	UG/L	N.S.	37700	38500	49700	38400	37800	38000	37600	37100
Chemical Oxygen Demand	MG/L							65.4		
Chloride	MG/L	250	68	60	67	71	54.1	44	53	8
Chromium	UG/L	50	12	30	96	13	11		24	1.2
Cobalt	UG/L							0.91		
Color (Pt/Co. Units)	PT/CO	15	2.5	10	10			7.84	2	5
Copper	UG/L	200						4.6	11	
Cyanide, Total	UG/L	200								
Dissolved Oxygen										
eH (millivolts)		N.S.								
Field Observation										
Floaters and sinkers (P/NP)										
Hardness (as CaCO <sub>3</sub> )			94.2	96.1	124	95.9	94.4	85.4	84.5	83.3
Hexavalent Chromium	UG/L	50								
Iron	UG/L	300	200	340	1300	110	120	310	130	
Lead	UG/L	15	6.4			5.1			370	
Magnesium	UG/L	35000	12700	13500	14200	13300	13300	13200	12800	12500
Manganese	UG/L	300		18	35			6.1	20	
Mercury	UG/L	0.7								
Nickel	UG/L	100			48		25	29		
Nitrate	MG/L	10	0.18	0.19	0.19		0.18	0.34		
pH (Std.)		6.5-8.5	8.8	7.96	9.18	8.67		7.3		
Potassium	UG/L	N.S.					2400	2300		
Selenium	UG/L	10								
Silver	UG/L	50								
Sodium	UG/L	20000	40300	40800	47400	40500	37800	34400	35800	39900
Specific Conductivity		N.S.	400	369	407	354		332		
Static Water Level (Ft.)										
Sulfate	MG/L	250	8.3	8.3	8.1	8.7	7.9			
Temperature (C)	MG/L	N.S.	13.8	9	10.9	14.4		11.8		
Thallium	UG/L	2								
Total Dissolved Solids	MG/L		284	302	298	348	320	332	300	286
Total Hardness	MG/L		146	152	183	151	149	134	132	130
Total Kjeldahl Nitrogen	MG/L									
Total Organic Carbon	MG/L		3.07	1	1.2			3.9	1.2	
Total Phenols	UG/L									
Turbidity (NUT)	NTU	N.S.	0.52	1.95	5.35	4.27	3.92	7.72	1.36	3.38
Vanadium	UG/L							7.5		
Zinc	UG/L	5000			30			6.2	10	

VOC

Acetone	UG/L	5								
Chloromethane	UG/L	5								
Methylene Chloride	UG/L	5								


Beryllium, Cadmium, Cyanide, Thallium, Chloride, Iron, Manganese, Sodium, Sulfate, Zinc and Color standards -

<http://www.health.state.ny.us/environmental/water/drinking/part5/tables.htm#table1>

Antimony, Arsenic, Barium, Chromium, Copper, Mercury, Nickel, Selenium, Silver - 6 NYSRR Part 703

\*casing bent 1998-2006

# MW-6S

PARAMETER	UNIT	STANDARD	2014	2014	2015	2015	2015	2015
			3rd Quarter	4th Quarter	1st Quarter	2nd Quarter	3rd Quarter	4th Quarter
Alkalinity (as CaCO <sub>3</sub> )	MG/L	N.S.	227	227	220	211	215	234
Aluminum	UG/L	N.S.					190	
Ammonia	MG/L	FEN OF T						
Antimony	UG/L	3					18	
Arsenic	UG/L	25						
BOD (5)	MG/L	N.S.						
BOD Time of Analysis)								
Barium	UG/L	1000				270	330	210
Beryllium	UG/L	4						
Boron	UG/L	10						
Bromide	UG/L	10						
Cadmium	UG/L	5						
Calcium	UG/L	N.S.	315000	304000	390000	519000	590000	402000
Chemical Oxygen Demand	MG/L			35.1	32.3	10.3	35.1	26.8
Chloride	MG/L	250	1940	1700	1800	3050	3420	2700
Chromium	UG/L	50	180	37	320	330	600	93
Cobalt	UG/L						14	0.62
Color (Pt/Co. Units)	PT/CO	15	15	30	30	30	30	
Copper	UG/L	200						4.2
Cyanide, Total	UG/L	200						
Dissolved Oxygen								
eH (millivolts)		N.S.						
Field Observation								
Floater and sinkers (P/NP)								
Hardness (as CaCO <sub>3</sub> )			786	758	974	1300	1470	903
Hexavalent Chromium	UG/L	50						
Iron	UG/L	300	1700	390	3100	2900	5800	510
Lead	UG/L	15				5.1	6.9	6.1
Magnesium	UG/L	35000	33800	31400	42300	54400	62400	41100
Manganese	UG/L	300	48	33	64	73	110	18
Mercury	UG/L	0.7						
Nickel	UG/L	100	48		93	120	220	34
Nitrate	MG/L	10	0.55	0.6	0.46	0.57	0.35	2.1
pH (Std.)		6.5-8.5	6.58	7.6	7.25	6.69	6.02	6.8
Potassium	UG/L	N.S.					2900	2500
Selenium	UG/L	10						
Silver	UG/L	50					0.97	
Sodium	UG/L	20000	850000	829000	1030000	126000	1400000	116000
Specific Conductivity		N.S.	2665	2718	2453	2926		2650
Static Water Level (Ft.)								
Sulfate	MG/L	250	70.6	88.4	61.9	57.2	79.2	
Temperature (C)	MG/L	N.S.	13.5	10.5	7.9	15.9		11.9
Thallium	UG/L	2						
Total Dissolved Solids	MG/L		3270	3850	4140	5630	6280	5090
Total Hardness	MG/L		925	888	1150	1520	1730	1060
Total Kjeldahl Nitrogen	MG/L							
Total Organic Carbon	MG/L		4.89	1.6	1.8	1.4	1.6	1.8
Total Phenols	UG/L							
Turbidity (NUT)	NTU	N.S.	17.02	23.81	29.7	16.84	53.8	6.96
Vanadium	UG/L							
Zinc	UG/L	5000					13	5.6

## VOC

Acetone	UG/L	5						
4-Methyl-2-pentanone	UG/L	5						

Beryllium, Cadmium, Cyanide, Thallium, Chloride, Iron, Manganese, Sodium, Sulfate, Zinc and Color standards -

<http://www.health.state.ny.us/environmental/water/drinking/part5/tables.htm#table1>

Antimony, Arsenic, Barium, Chromium, Copper, Mercury, Nickel, Selenium, Silver - 6 NYSRR Part 703



# MW-7D

PARAMETER	UNIT	STANDARD	2011	2013	2014	2015	2016
			2nd QUARTER	2nd QUARTER	3rd QUARTER	2nd QUARTER	2nd QUARTER
Alkalinity (as CaCO <sub>3</sub> )	MG/L	N.S.	145	128	128	181	
Aluminum	UG/L	N.S.				540	1000
Ammonia	MG/L	FEN OF T					
Antimony	UG/L	3					
Arsenic	UG/L	25					
BOD (5)	MG/L	N.S.					9
BOD Time of Analysis)							
Barium	UG/L	1000					
Beryllium	UG/L	4					
Boron	UG/L	10					
Bromide	UG/L	10					
Cadmium	UG/L	5					
Calcium	UG/L	N.S.	42400	40600	35800	50500	45200
Chemical Oxygen Demand	MG/L			64.4			
Chloride	MG/L	250		41.5	38.8	10	9
Chromium	UG/L	50	32			22	24
Cobalt	UG/L						
Color (Pt/Co. Units)	PT/CO	15	2.5	5	2.5	15	20
Copper	UG/L	200					
Cyanide, Total	UG/L	200					
Dissolved Oxygen							
eH (millivolts)		N.S.					
Field Observation							
Floater and sinkers (P/NP)							
Hardness (as CaCO <sub>3</sub> )			148	101	89.4	126	102
Hexavalent Chromium	UG/L	50					
Iron	UG/L	300		160		1000	1200
Lead	UG/L	15				5.6	
Magnesium	UG/L	35000	10300	9100	8600	11700	11200
Manganese	UG/L	300		18		65	38
Mercury	UG/L	0.7					
Nickel	UG/L	100					
Nitrate	MG/L	10	0.22	0.25	0.21		
pH (Std.)		6.5-8.5		7.47	7.41	7.99	
Potassium	UG/L	N.S.					
Selenium	UG/L	10					
Silver	UG/L	50					
Sodium	UG/L	20000	33400	37200	32400	21300	20600
Specific Conductivity		N.S.		438	293	280	
Static Water Level (Ft.)							
Sulfate	MG/L	250	26.2	31	31.3	17.1	
Temperature (C)	MG/L	N.S.		13.6	13.6	12.6	
Thallium	UG/L	2					
Total Dissolved Solids	MG/L		240	236	244	274	244
Total Hardness	MG/L		148	139	125	174	143
Total Kjeldahl Nitrogen	MG/L						
Total Organic Carbon	MG/L		1.5	1.1	1.49		2.2
Total Phenols	UG/L						
Turbidity (NTU)	NTU	N.S.	0.676	4.28	1.55	18.95	27.2
Vanadium	UG/L						
Zinc	UG/L	5000				31	
VOC							
Acetone	UG/L	5					
Chloromethane	UG/L	5					
Methylene Chloride	UG/L	5					
Benzene	UG/L	5					

Beryllium, Cadmium, Cyanide, Thallium, Chloride, Iron, Manganese, Sodium, Sulfate, Zinc and Color standards - <http://www.health.state.ny.us/environmental/water/drinking/part5/tables.htm#table1>  
 Antimony, Arsenic, Barium, Chromium, Copper, Mercury, Nickel, Selenium, Silver - 6 NYSRR Part 703

# MW-8D

PARAMETER	UNIT	STANDARD	2011	2013	2014	2015	2016
			2nd QUARTER	2nd QUARTER	3rd QUARTER	2nd QUARTER	2nd QUARTER
Alkalinity (as CaCO <sub>3</sub> )	MG/L	N.S.	127	116	122	125	127
Aluminum	UG/L	N.S.		240		320	580
Ammonia	MG/L	FEN OF T		0.059			
Antimony	UG/L	3					
Arsenic	UG/L	25					
BOD (5)	MG/L	N.S.					4.2
BOD Time of Analysis)							
Barium	UG/L	1000					
Beryllium	UG/L	4					
Boron	UG/L	10					
Bromide	UG/L	10					
Cadmium	UG/L	5					
Calcium	UG/L	N.S.	45500	44500	40400	47000	42500
Chemical Oxygen Demand	MG/L			66.9			
Chloride	MG/L	250	14	19.3	14.6	16	16
Chromium	UG/L	50					
Cobalt	UG/L						
Color (Pt/Co. Units)	PT/CO	15	15	10	2.5	15	10
Copper	UG/L	200					
Cyanide, Total	UG/L	200					
Dissolved Oxygen							
eH (millivolts)		N.S.					
Field Observation							
Floater and sinkers (P/NP)							
Hardness (as CaCO <sub>3</sub> )			114	111	101	117	95.4
Hexavalent Chromium	UG/L	50					
Iron	UG/L	300	1500	1600	170	1400	520
Lead	UG/L	15		26			
Magnesium	UG/L	35000	12400	11900	11600	13000	12000
Manganese	UG/L	300	27	54	21	70	91
Mercury	UG/L	0.7					
Nickel	UG/L	100					
Nitrate	MG/L	10	0.35	0.27	0.21	0.36	
pH (Std.)		6.5-8.5		7.69	8	8.06	
Potassium	UG/L	N.S.					
Selenium	UG/L	10					
Silver	UG/L	50					
Sodium	UG/L	20000	7600	7300	6400	8700	8400
Specific Conductivity		N.S.		354	248	246	
Static Water Level (Ft.)							
Sulfate	MG/L	250	34.5	34.2	35.4	36	35.9
Temperature (C)	MG/L	N.S.		12.7	13.2	18.4	
Thallium	UG/L	2					
Total Dissolved Solids	MG/L		234	192	246	252	236
Total Hardness	MG/L		165	160	149	171	140
Total Kjeldahl Nitrogen	MG/L						
Total Organic Carbon	MG/L			2.3	1.94		2.1
Total Phenols	UG/L					0.022	
Turbidity (NUT)	NTU	N.S.	4.06	7.44	0.51	9.53	8.65
Vanadium	UG/L						
Zinc	UG/L	5000		53		23	22
Acetone	UG/L	5					
Chloromethane	UG/L	5					
Methylene Chloride	UG/L	5					
Benzene	UG/L	5					

Beryllium, Cadmium, Cyanide, Thallium, Chloride, Iron, Manganese, Sodium, Sulfate, Zinc and Color standards - <http://www.health.state.ny.us/environmental/water/drinking/part5/tables.htm#table1>  
 Antimony, Arsenic, Barium, Chromium, Copper, Mercury, Nickel, Selenium, Silver - 6 NYSRR Part 703



MW-9S

PARAMETER	UNIT	STANDARD	2014	2014	2015	2015	2015	2015
			3rd Quarter	4th Quarter	1st Quarter	2nd Quarter	3rd Quarter	4th Quarter
Alkalinity (as CaCO <sub>3</sub> )	MG/L	N.S.	570	439	438	550	603	441
Aluminum	UG/L	N.S.					41	
Ammonia	MG/L	FEN OF T		24.5			71.8	14.8
Antimony	UG/L	3						
Arsenic	UG/L	25						
BOD (5)	MG/L	N.S.	29.3	22.9	17.9	36.6	14.9	12.4
BOD Time of Analysis)								
Barium	UG/L	1000	520	340	410	480	620	
Beryllium	UG/L	4						
Boron	UG/L	10	150	150	130	150	200	130
Bromide	UG/L	10						
Cadmium	UG/L	5					0.96	0.28
Calcium	UG/L	N.S.	113000	106000	126000	128000	132000	108000
Chemical Oxygen Demand	MG/L			29.6	25.8	24.1	35.1	24.1
Chloride	MG/L	250	85.4	29	24	66	76.6	29
Chromium	UG/L	50						3.3
Cobalt	UG/L							0.65
Color (Pt/Co. Units)	PT/CO	15	100	50	75	300	200	75
Copper	UG/L	200						28
Cyanide, Total	UG/L	200						
Dissolved Oxygen								
eH (millivolts)		N.S.						
Field Observation								
Floaters and sinkers (P/NP)								
Hardness (as CaCO <sub>3</sub> )			282	266	315	321	331	242
Hexavalent Chromium	UG/L	50						
Iron	UG/L	300	53800	33100	54500	54300	63300	29000
Lead	UG/L	15	8.5					
Magnesium	UG/L	35000	18500	13600	20000	20400	23100	13100
Manganese	UG/L	300	1200	1100	1900	1400	1400	910
Mercury	UG/L	0.7						
Nickel	UG/L	100					1.6	1.7
Nitrate	MG/L	10		0.051	0.08			
pH (Std.)		6.5-8.5	6.65	7.2	7.08	6.51		
Potassium	UG/L	N.S.					4000	2300
Selenium	UG/L	10						
Silver	UG/L	50						
Sodium	UG/L	20000	44400	23300	26800	36700	39100	18300
Specific Conductivity		N.S.	846	655	578	704		
Static Water Level (Ft.)								
Sulfate	MG/L	250						
Temperature (C)	MG/L	N.S.	16	8.8	7.2	11.7		
Thallium	UG/L	2						
Total Dissolved Solids	MG/L		640	442	484	614	628	442
Total Hardness	MG/L		358	322	398	404	426	291
Total Kjeldahl Nitrogen	MG/L		42	19.6		39.2	47.3	14.9
Total Organic Carbon	MG/L		16.8	9.2	11.7	9.2	13.8	11.9
Total Phenols	UG/L				0.013	0.031		
Turbidity (NUT)	NTU	N.S.	22.21	11.69	14.52	0.78	445	37.7
Vanadium	UG/L							10
Zinc	UG/L	5000	23		21		15	6.1

VOC

Acetone	UG/L	5						
Acrylonitrile	UG/L	5						
Benzene	UG/L	5	0.21					
Chlorobenzene	UG/L	5	5.2	4.8	5.6	5.2	5.4	
Chloroethane	UG/L	5	11	8	7.3	9.3	12	
Chloromethane	UG/L	5						
1,2 Dichlorobenzene	UG/L	5	1.9	1.4	0.89	1.1	1.6	
1,4 Dichlorobenzene	UG/L	5	0.72	0.55				
o-Xylene	UG/L	5						
Toluene	UG/L	5						
Methylene Chloride	UG/L	5						
Carbon Disulfide	UG/L	5						
m-Xylene	UG/L	5						

Beryllium, Cadmium, Cyanide, Thallium, Chloride, Iron, Manganese, Sodium, Sulfate, Zinc and Color standards -

<http://www.health.state.ny.us/environmental/water/drinking/part5/tables.htm#table1>

Antimony, Arsenic, Barium, Chromium, Copper, Mercury, Nickel, Selenium, Silver - 6 NYSRR Part 703

# MW-10D

PARAMETER	UNIT	STANDARD	2011	2013	2014	2015	2016
			2nd QUARTER	2nd QUARTER	3rd QUARTER	2nd QUARTER	2nd QUARTER
Aikality (as CaCO <sub>3</sub> )	MG/L	N.S.	133	141	144	136	140
Aluminum	UG/L	N.S.					
Ammonia	MG/L	FEN OF T					
Antimony	UG/L	3					
Arsenic	UG/L	25					
BOD (5)	MG/L	N.S.					
BOD Time of Analysis)							
Barium	UG/L	1000					
Beryllium	UG/L	4					
Boron	UG/L	10					
Bromide	UG/L	10					
Cadmium	UG/L	5					
Calcium	UG/L	N.S.	35500	35600	31900	39400	32800
Chemical Oxygen Demand	MG/L		24	62			
Chloride	MG/L	250					
Chromium	UG/L	50					
Cobalt	UG/L						
Color (Pt/Co. Units)	PT/CO	15	2.5	5	15	15	15
Copper	UG/L	200					
Cyanide, Total	UG/L	200					
Dissolved Oxygen							
eH (millivolts)		N.S.					
Field Observation							
Floater and sinkers (P/NP)							
Hardness (as CaCO <sub>3</sub> )			88.7	88.9	79.8	98.3	73.8
Hexavalent Chromium	UG/L	50					
Iron	UG/L	300	120	210	570	600	130
Lead	UG/L	15			5.3		
Magnesium	UG/L	35000	13000	12600	11900	14200	11900
Manganese	UG/L	300	44	21	23		
Mercury	UG/L	0.7					
Nickel	UG/L	100					
Nitrate	MG/L	10			0.18		
pH (Std.)		6.5-8.5		7.99	8.31	8.1	
Potassium	UG/L	N.S.					
Selenium	UG/L	10					
Silver	UG/L	50					
Sodium	UG/L	20000					
Specific Conductivity		N.S.		285	220	190	
Static Water Level (Ft.)							
Sulfate	MG/L	250	9.9	10.8	11.6	10.8	
Temperature (C)	MG/L	N.S.		17.4	14.2	12.3	
Thallium	UG/L	2					
Total Dissolved Solids	MG/L		144	144	176	194	196
Total Hardness	MG/L		142	141	129	157	118
Total Kjeldahl Nitrogen	MG/L						
Total Organic Carbon	MG/L		1.5		3.59		2.2
Total Phenols	UG/L			0.013	0.011		
Turbidity (NUT)	NTU	N.S.	1.17	2.48	13.74	18.01	5.59
Vanadium	UG/L						
Zinc	UG/L	5000			160		

VOC							
Acetone	UG/L	5					
Chloromethane	UG/L	5					
Methylene Chloride	UG/L	5					
Benzene	UG/L	5					
Carbon Disulfide	UG/L	5					

Beryllium, Cadmium, Cyanide, Thallium, Chloride, Iron, Manganese, Sodium, Sulfate, Zinc and Color standards - <http://www.health.state.ny.us/environmental/water/drinking/parts/tables.htm#table1>  
 Antimony, Arsenic, Barium, Chromium, Copper, Mercury, Nickel, Selenium, Silver - 6 NYSRR Part 703



# MW-10S

PARAMETER	UNIT	STANDARD	2011	2013	2014	2015	2016
			2nd QUARTER	2nd QUARTER	3rd QUARTER	2nd QUARTER	2nd QUARTER
Alkalinity (as CaCO <sub>3</sub> )	MG/L	N.S.	153	121	108	117	120
Aluminum	UG/L	N.S.	5500	2400		1000	27600
Ammonia	MG/L	FFN OF T					
Antimony	UG/L	3					
Arsenic	UG/L	25					
BOD (5)	MG/L	N.S.					
BOD Time of Analysis)							
Barium	UG/L	1000					
Beryllium	UG/L	4					
Boron	UG/L	10					
Bromide	UG/L	10					
Cadmium	UG/L	5					
Calcium	UG/L	N.S.	45200	44000	41300	45500	47400
Chemical Oxygen Demand	MG/L		21	62			
Chloride	MG/L	250					
Chromium	UG/L	50					29
Cobalt	UG/L						
Color (Pt/Co. Units)	PT/CO	15		25	30	30	750
Copper	UG/L	200					51
Cyanide, Total	UG/L	200					
Dissolved Oxygen							
eH (millivolts)		N.S.					
Field Observation							
Floaters and sinkers (P/NP)							
Hardness (as CaCO <sub>3</sub> )			113	110	103	114	107
Hexavalent Chromium	UG/L	50					
Iron	UG/L	300	7800	3000	1300	1200	28000
Lead	UG/L	15	6.3				
Magnesium	UG/L	35000	5300				9600
Manganese	UG/L	300	320	140	250	150	570
Mercury	UG/L	0.7					
Nickel	UG/L	100					
Nitrate	MG/L	10	0.095	0.09	0.15		
pH (Std.)		6.5-8.5		7.72	8.58	8.23	
Potassium	UG/L	N.S.					8900
Selenium	UG/L	10					
Silver	UG/L	50					
Sodium	UG/L	20000					
Specific Conductivity		N.S.		257	201	186	
Static Water Level (Ft.)							
Sulfate	MG/L	250	13.8	13.7	12.3	13.9	
Temperature (C)	MG/L	N.S.		13.9	17.3	17.8	
Thallium	UG/L	2					
Total Dissolved Solids	MG/L		166	150	168	166	200
Total Hardness	MG/L		135	128	118	131	142
Total Kjeldahl Nitrogen	MG/L		1.1				
Total Organic Carbon	MG/L				2.49		1.2
Total Phenols	UG/L						
Turbidity (NUT)	NTU	N.S.	52.9	66.1	5.98	9.79	4000
Vanadium	UG/L						57
Zinc	UG/L	5000	31	21		26	130
VOC							
Acetone	UG/L	5					
Methylene Chloride	UG/L	5					

Beryllium, Cadmium, Cyanide, Thallium, Chloride, Iron, Manganese, Sodium, Sulfate, Zinc and Color standards - <http://www.health.state.ny.us/environmental/water/drinking/part5/tables.htm#table1>  
 Antimony, Arsenic, Barium, Chromium, Copper, Mercury, Nickel, Selenium, Silver - 6 NYSRR Part 703

**MW-11S**

PARAMETER	UNIT	STANDARD	2014	2014	2015	2015	2015
			3rd Quarter	4th Quarter	1st Quarter	2nd Quarter	3rd Quarter
Alkalinity (as CaCO <sub>3</sub> )	MG/L	N.S.	231	234	225	220	241
Aluminum	UG/L	N.S.		21500		9200	20000
Ammonia	MG/L	FEN OF T					
Antimony	UG/L	3					
Arsenic	UG/L	25					15
BOD (5)	MG/L	N.S.					
BOD Time of Analysis)							
Barium	UG/L	1000					160
Beryllium	UG/L	4					0.59
Boron	UG/L	10					10
Bromide	UG/L	10					
Cadmium	UG/L	5					0.59
Calcium	UG/L	N.S.	125000	156000	146000	144000	165000
Chemical Oxygen Demand	MG/L			13		18.5	37.8
Chloride	MG/L	250	165	165	170	185	199
Chromium	UG/L	50			17	11	26
Cobalt	UG/L						14
Color (Pt/Co. Units)	PT/CO	15	25	20	30	20	10
Copper	UG/L	200		42	26		41
Cyanide, Total	UG/L	200					
Dissolved Oxygen							
eH (millivolts)		N.S.					
Field Observation							
Floaters and sinkers (P/NP)							
Hardness (as CaCO <sub>3</sub> )			313	390	364	359	413
Hexavalent Chromium	UG/L	50					
Iron	UG/L	300	7300	36800	20500	16000	33300
Lead	UG/L	15	37	15	34	7.7	15
Magnesium	UG/L	35000	20300	29300	25800	24100	29000
Manganese	UG/L	300	2500	2700	1100	2200	2200
Mercury	UG/L	0.7					
Nickel	UG/L	100					29
Nitrate	MG/L	10		0.047	0.061		
pH (Std.)		6.5-8.5	7.46	7.59	4.8	7.26	7.02
Potassium	UG/L	N.S.		5800			4900
Selenium	UG/L	10					
Silver	UG/L	50					0.6
Sodium	UG/L	20000	57700	50200	56900	58200	63400
Specific Conductivity		N.S.	644	655	606	552	
Static Water Level (Ft.)							
Sulfate	MG/L	250	38.6	43.2	41.7	44.5	40.8
Temperature (C)	MG/L	N.S.	16.6	8.3	8.77	14.6	
Thallium	UG/L	2					
Total Dissolved Solids	MG/L		730	692	680	720	712
Total Hardness	MG/L		397	511	470	458	532
Total Kjeldahl Nitrogen	MG/L						
Total Organic Carbon	MG/L		3.02	2	1.9	1.3	1.9
Total Phenols	UG/L						20
Turbidity (NUT)	NTU	N.S.	29.95	466.5	66.26	58.25	620
Vanadium	UG/L						29
Zinc	UG/L	5000	60	100	120	57	98

**VOC**

Acetone	UG/L	5					
Chlorobenzene	UG/L	5					
Chloroethane	UG/L	5					
Hexanone	UG/L	5					
Methyl Ethyl Ketone	UG/L	5					
Toluene	UG/L	5					
Carbon Disulfide	UG/L	5					
Methylene Chloride	UG/L	5					

Beryllium, Cadmium, Cyanide, Thallium, Chloride, Iron, Manganese, Sodium, Sulfate, Zinc and Color standards -

<http://www.health.state.ny.us/environmental/water/drinking/part5/tables.htm#table1>

Antimony, Arsenic, Barium, Chromium, Copper, Mercury, Nickel, Selenium, Silver - 6 NYSRR Part 703



# MW-SW1

PARAMETER	UNIT	STANDARD	2009	2013	2014	2015	2016
			1st QUARTER	2nd QUARTER	3rd QUARTER	2nd QUARTER	2nd QUARTER
Alkalinity (as CaCO <sub>3</sub> )	MG/L	N.S.		132	85.7	142	141
Aluminum	UG/L	N.S.		610		760	2000
Ammonia	MG/L	FEN OF T		0.12			
Antimony	UG/L	3					
Arsenic	UG/L	25					
BOD (5)	MG/L	N.S.					5.5
BOD Time of Analysis)							
Barium	UG/L	1000					
Beryllium	UG/L	4					
Boron	UG/L	10					
Bromide	UG/L	10					
Cadmium	UG/L	5					
Calcium	UG/L	N.S.		50100	36700	64100	63400
Chemical Oxygen Demand	MG/L			76.6		35.1	
Chloride	MG/L	250		50.1	67	150	130
Chromium	UG/L	50					
Cobalt	UG/L						
Color (Pt/Co. Units)	PT/CO	15		100	75	75	250
Copper	UG/L	200					
Cyanide, Total	UG/L	200					
Dissolved Oxygen							
eH (millivolts)		N.S.	341				
Field Observation							
Floaters and sinkers (P/NP)							
Hardness (as CaCO <sub>3</sub> )				125	91.6	160	142
Hexavalent Chromium	UG/L	50					
Iron	UG/L	300		3400	3500	8000	4100
Lead	UG/L	15			6.8	8.9	10
Magnesium	UG/L	35000		5900	5100	6600	7200
Manganese	UG/L	300		140	1500	440	720
Mercury	UG/L	0.7					
Nickel	UG/L	100					
Nitrate	MG/L	10		0.2			
pH (Std.)		6.5-8.5	7.19	7.72	7.63	7.5	
Potassium	UG/L	N.S.					
Selenium	UG/L	10					
Silver	UG/L	50					
Sodium	UG/L	20000		20800	26600	82300	52500
Specific Conductivity		N.S.	163	381	296	457	
Static Water Level (Ft.)							
Sulfate	MG/L	250		6.6			6
Temperature (C)	MG/L	N.S.	6.4	19.3	23.4	20.4	
Thallium	UG/L	2					
Total Dissolved Solids	MG/L			180	338	520	466
Total Hardness	MG/L			150	113	187	169
Total Kjeldahl Nitrogen	MG/L				2.3		2.3
Total Organic Carbon	MG/L			6.9	13.3	12.2	12.1
Total Phenols	UG/L			0.01			
Turbidity (NUT)	NTU	N.S.	2.74	20.2	3.69	6.19	4000
Vanadium	UG/L						
Zinc	UG/L	5000				36	67
VOC							
Acetone	UG/L	5			2.4		5.9
Hexanone	UG/L	5					
Methylene Chloride	UG/L	5					
Toluene	UG/L	5					
m,p-Xylene	UG/L	5					

Beryllium, Cadmium, Cyanide, Thallium, Chloride, Iron, Manganese, Sodium, Sulfate, Zinc and Color standards - <http://www.health.state.ny.us/environmental/water/drinking/part5/tables.htm#table1>  
 Antimony, Arsenic, Barium, Chromium, Copper, Mercury, Nickel, Selenium, Silver - 6 NYSRR Part 703

MW-SW2

PARAMETER	UNIT	STANDARD	2009	2013	2014	2015	2016
			1st QUARTER	2nd QUARTER	3rd QUARTER	2nd QUARTER	2nd QUARTER
Alkalinity (as CaCO <sub>3</sub> )	MG/L	N.S.		148	167	146	146
Aluminum	UG/L	N.S.				330	250
Ammonia	MG/L	FEN OF T		0.21			
Antimony	UG/L	3					
Arsenic	UG/L	25					
BOD (5)	MG/L	N.S.					5.5
BOD Time of Analysis)							
Barium	UG/L	1000					
Beryllium	UG/L	4					
Boron	UG/L	10					
Bromide	UG/L	10					
Cadmium	UG/L	5					
Calcium	UG/L	N.S.		49700	58200	63600	60400
Chemical Oxygen Demand	MG/L			69.3		29.6	37.9
Chloride	MG/L	250		77.1	70.9	170	130
Chromium	UG/L	50					
Cobalt	UG/L						
Color (Pt/Co. Units)	PT/CO	15		150	100	250	200
Copper	UG/L	200					
Cyanide, Total	UG/L	200					
Dissolved Oxygen							
eH (millivolts)		N.S.	872				
Field Observation							
Floater and sinkers (P/NP)							
Hardness (as CaCO <sub>3</sub> )				124	145	159	136
Hexavalent Chromium	UG/L	50					
Iron	UG/L	300		920	2100	5900	2600
Lead	UG/L	15					
Magnesium	UG/L	35000		5700	8700	7500	7700
Manganese	UG/L	300		96	470	620	560
Mercury	UG/L	0.7					
Nickel	UG/L	100					
Nitrate	MG/L	10		0.15			
pH (Std.)		6.5-8.5	7.23	7.99	7.23	7.23	
Potassium	UG/L	N.S.					
Selenium	UG/L	10					
Silver	UG/L	50					
Sodium	UG/L	20000		43300	174000	90900	60300
Specific Conductivity		N.S.	135	487	833	490	
Static Water Level (Ft.)							
Sulfate	MG/L	250		6	6.5	5.1	6.1
Temperature (C)	MG/L	N.S.	10.2	21.5	21.8	19.7	
Thallium	UG/L	2					
Total Dissolved Solids	MG/L			222	894	544	468
Total Hardness	MG/L			147	181	190	164
Total Kjeldahl Nitrogen	MG/L						2.3
Total Organic Carbon	MG/L			11.2	12.5	12.6	10.3
Total Phenols	UG/L			0.01		0.015	
Turbidity (NUT)	NTU	N.S.	4.98	3.08	8.98	17.8	14
Vanadium	UG/L						
Zinc	UG/L	5000					
VOC	UG/L	5					
	UG/L	5					
Acetone	UG/L	5	1.3				
Methylene Chloride	UG/L	5					

Beryllium, Cadmium, Cyanide, Thallium, Chloride, Iron, Manganese, Sodium, Sulfate, Zinc and Color standards - <http://www.health.state.ny.us/environmental/water/drinking/part5/tables.htm#table1>  
 Antimony, Arsenic, Barium, Chromium, Copper, Mercury, Nickel, Selenium, Silver - 6 NYSRR Part 703

# **ATTACHMENT 4**

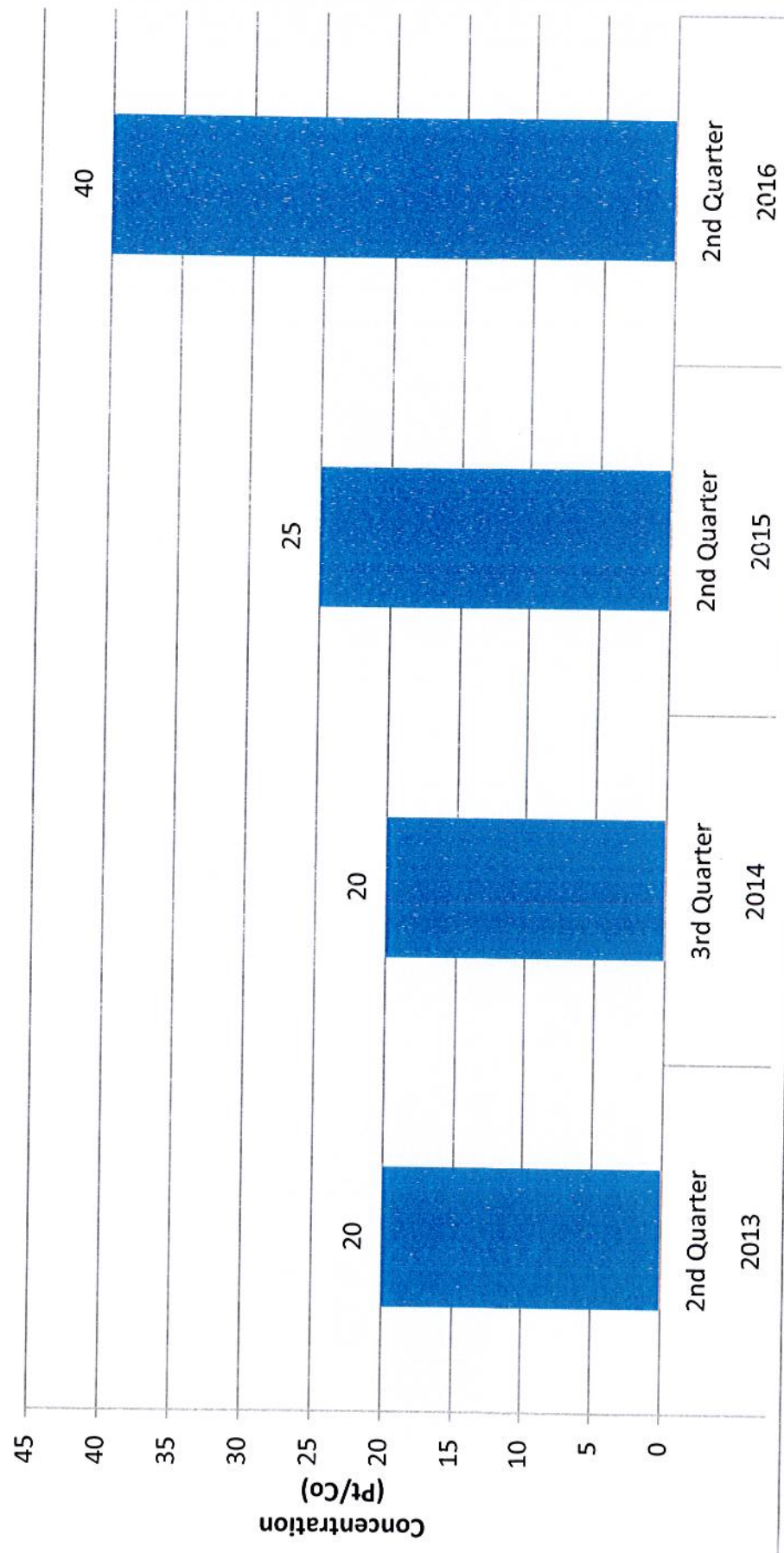




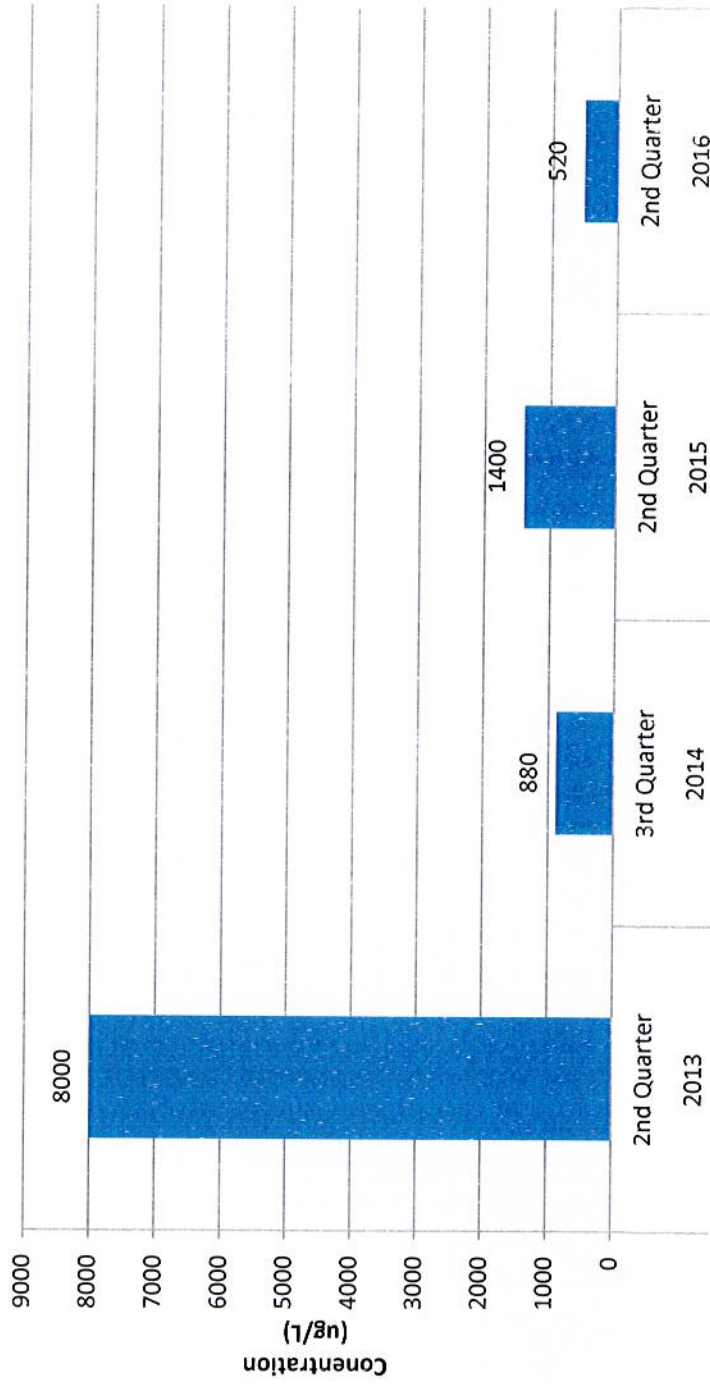
# New Windsor Landfill Quarterly Monitoring Reports

MW 1D

Color



**New Windsor Landfill Quarterly Monitoring Reports**  
**MW 1D**  
**Iron**

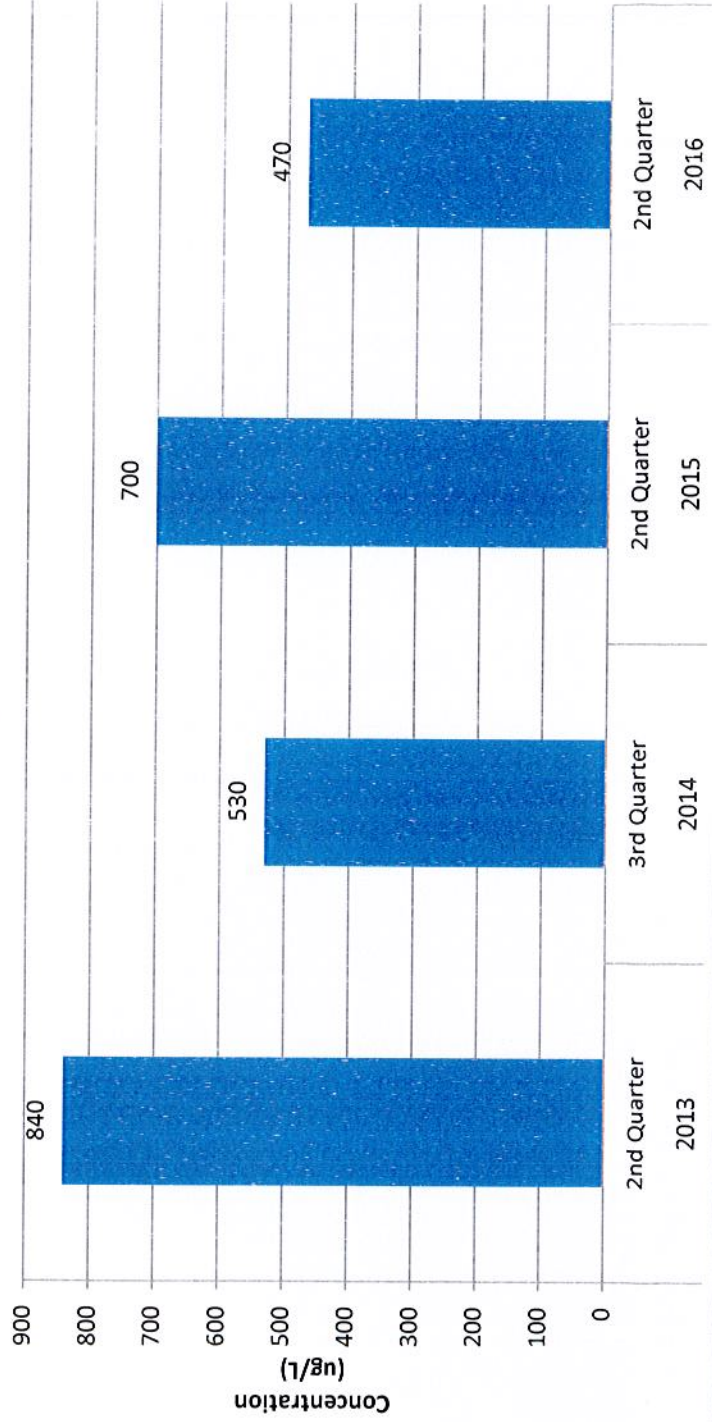




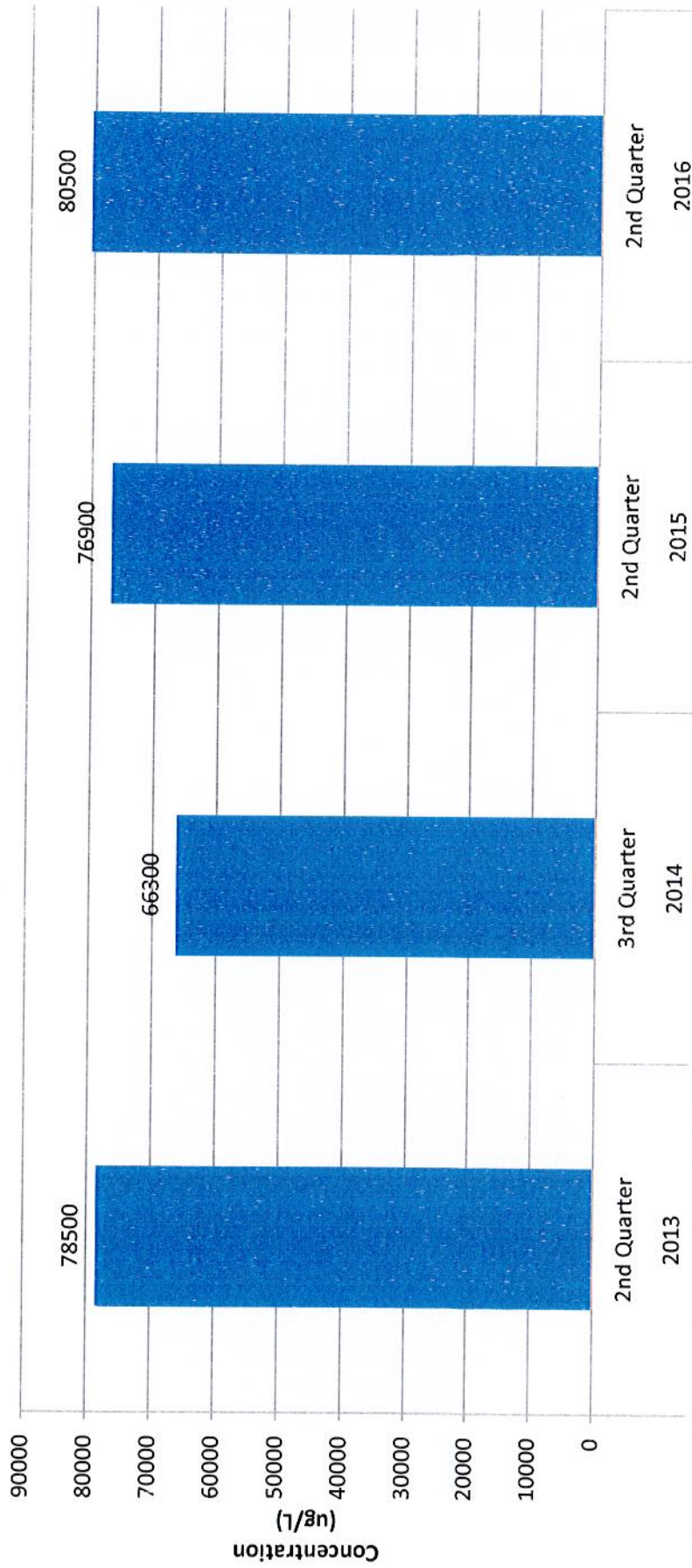
# New Windsor Landfill Quarterly Monitoring Reports

MW 1D

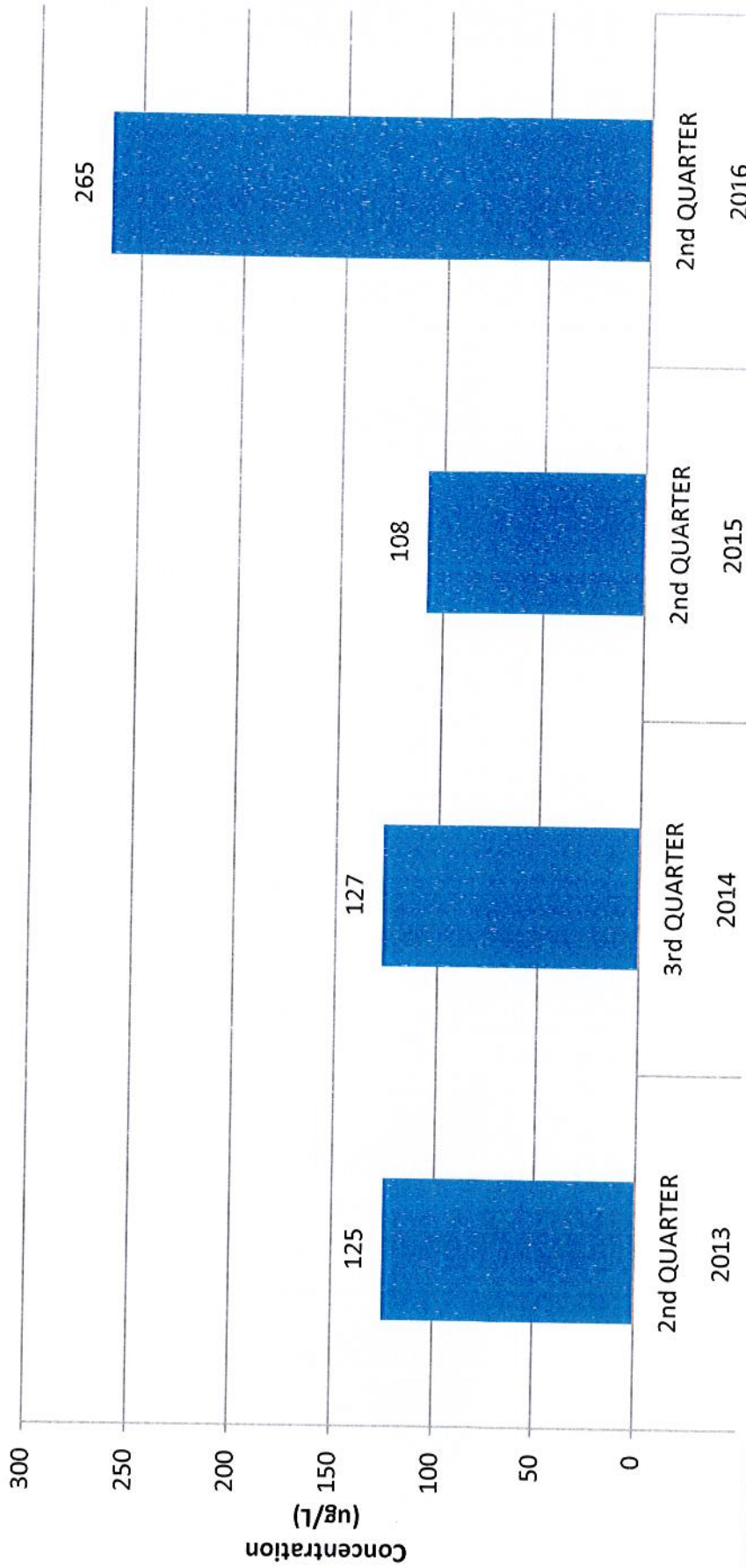
Manganese



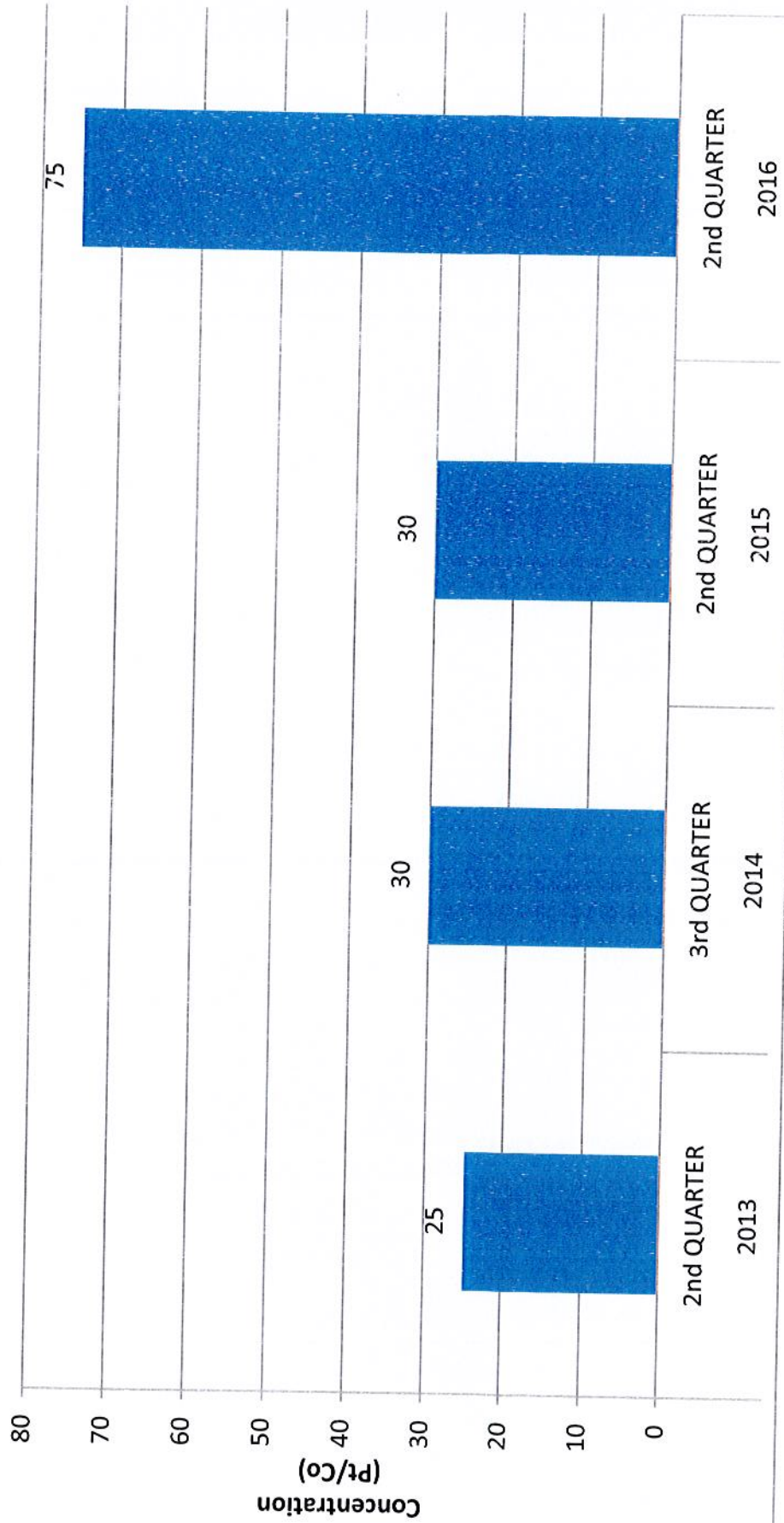
**New Windsor Landfill Quarterly Monitoring Reports  
MW 1D  
Sodium**



**New Windsor Landfill Quarterly Monitoring Reports  
MW 1S  
Chloride**

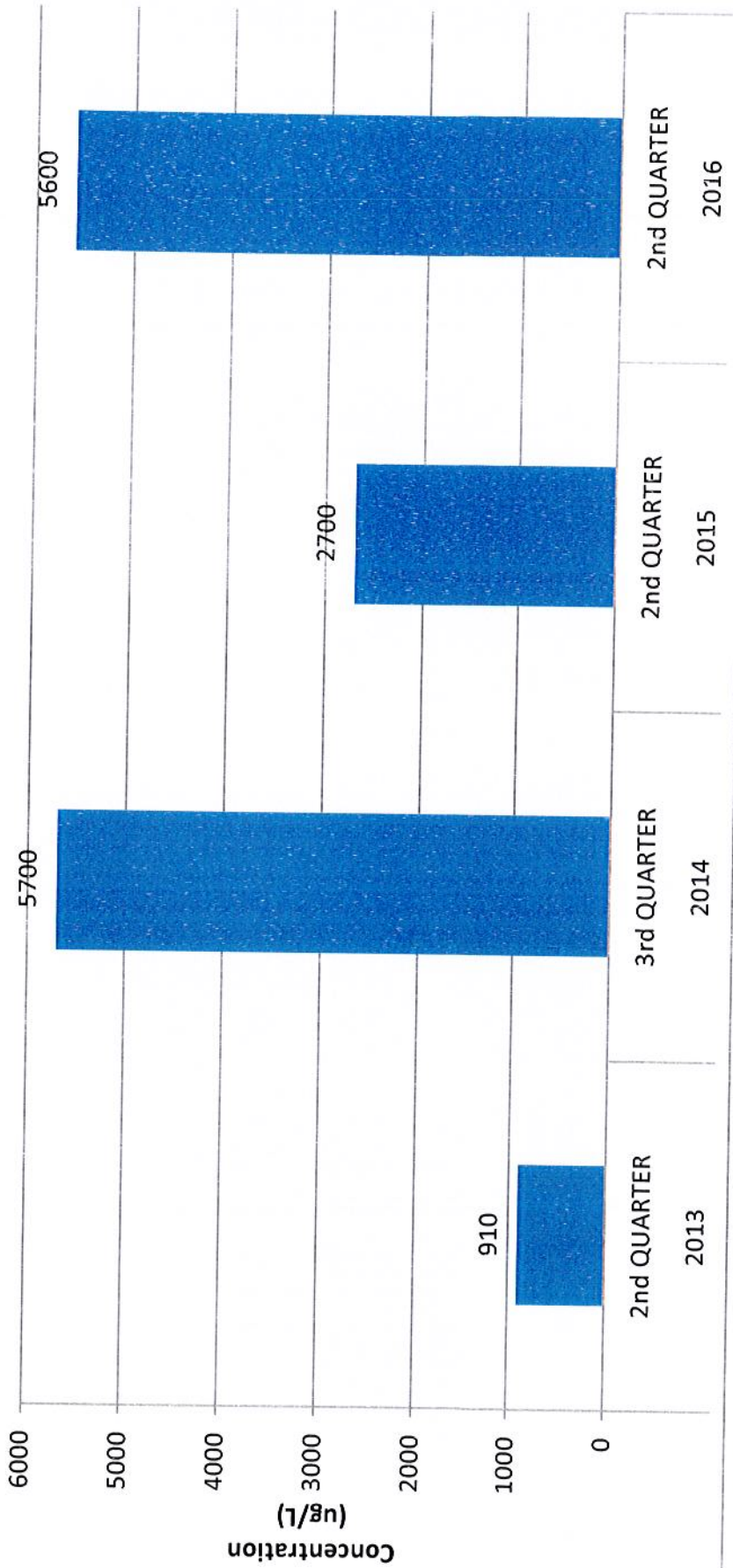


**New Windsor Landfill Quarterly Monitoring Reports  
MW 1S  
Color**

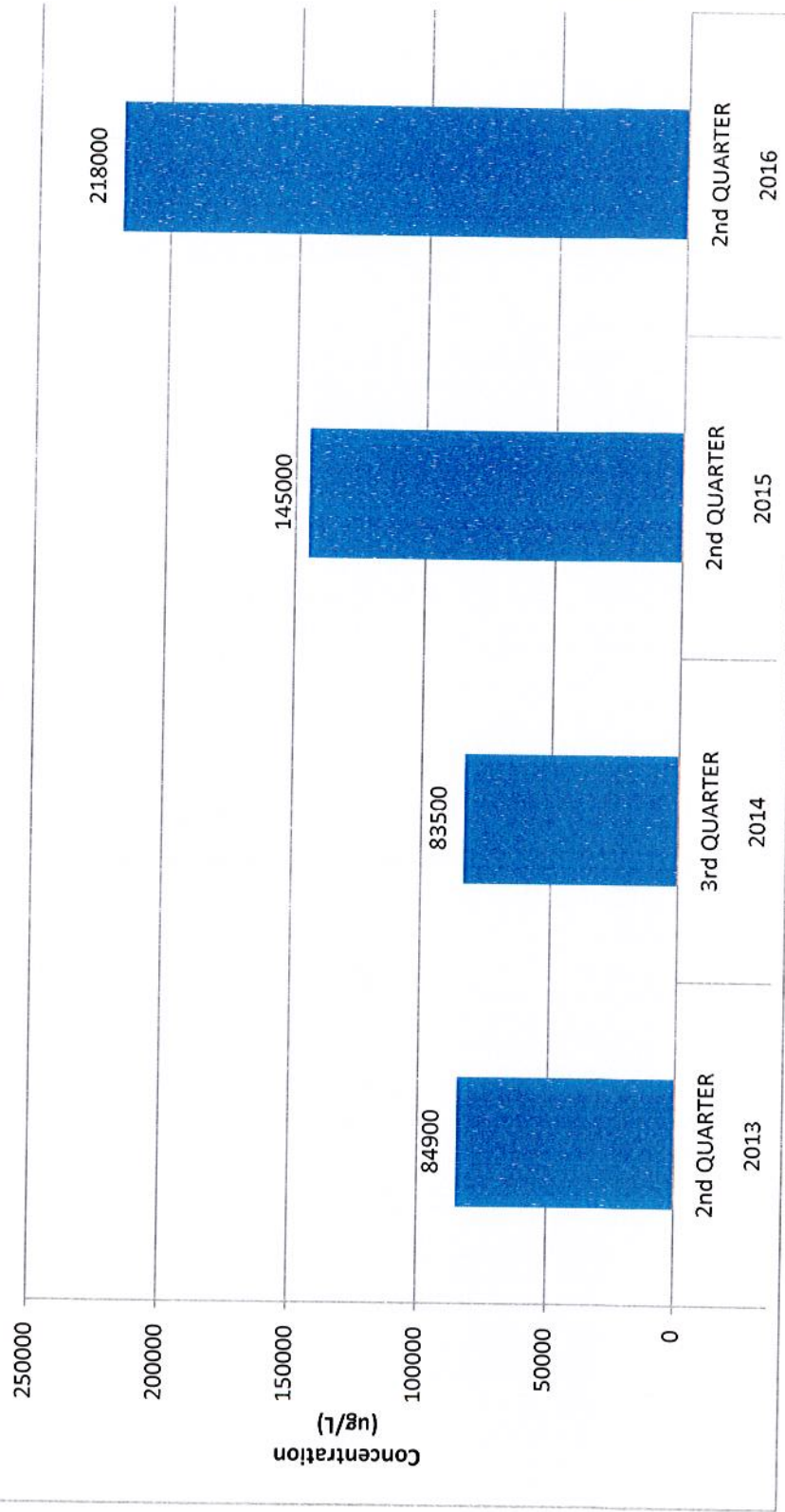




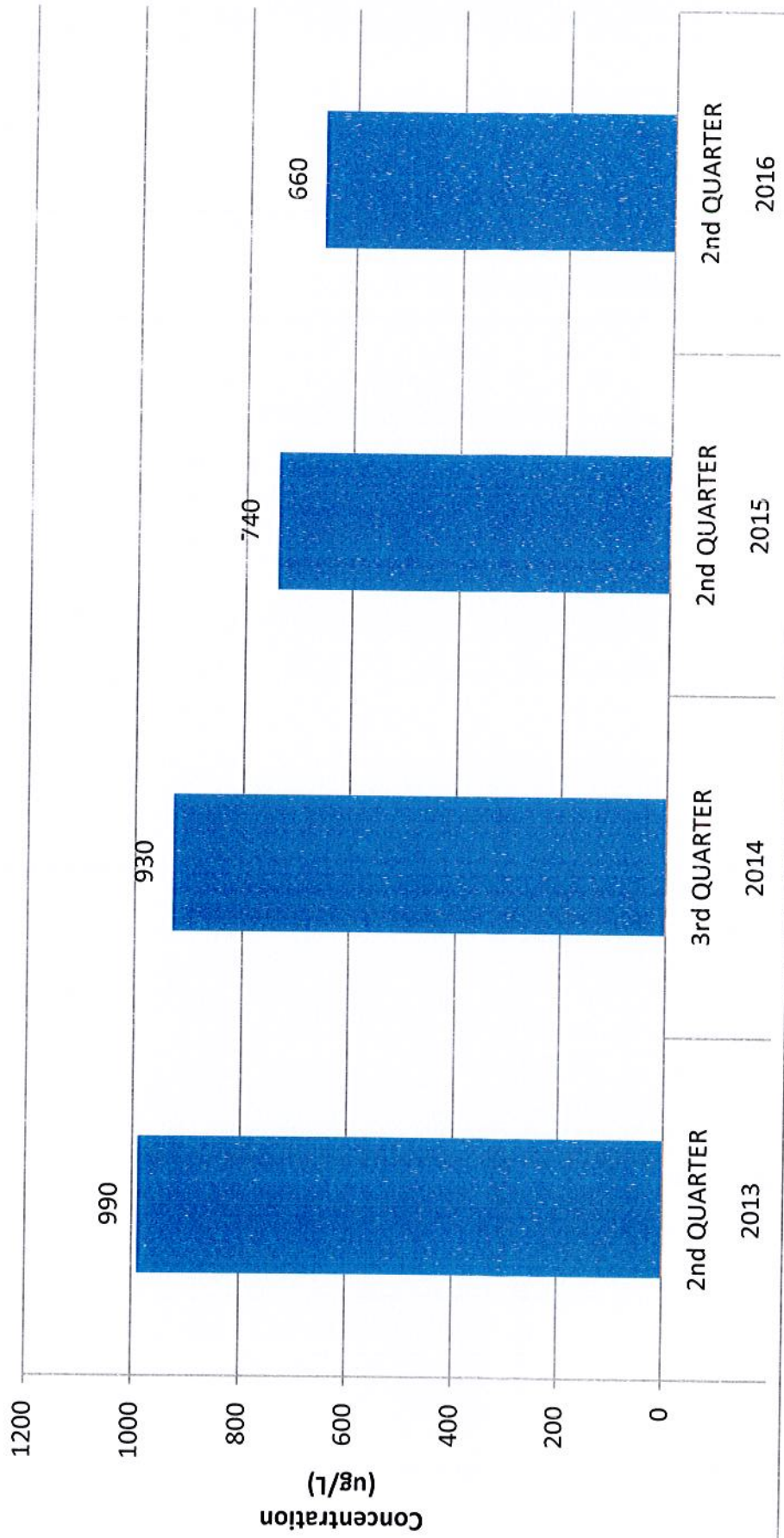
**New Windsor Landfill Quarterly Monitoring Reports  
MW 1S  
Iron**



**New Windsor Landfill Quarterly Monitoring Reports  
MW 15  
Sodium**



**New Windsor Landfill Quarterly Monitoring Reports**  
**MW 3D**  
**Iron**

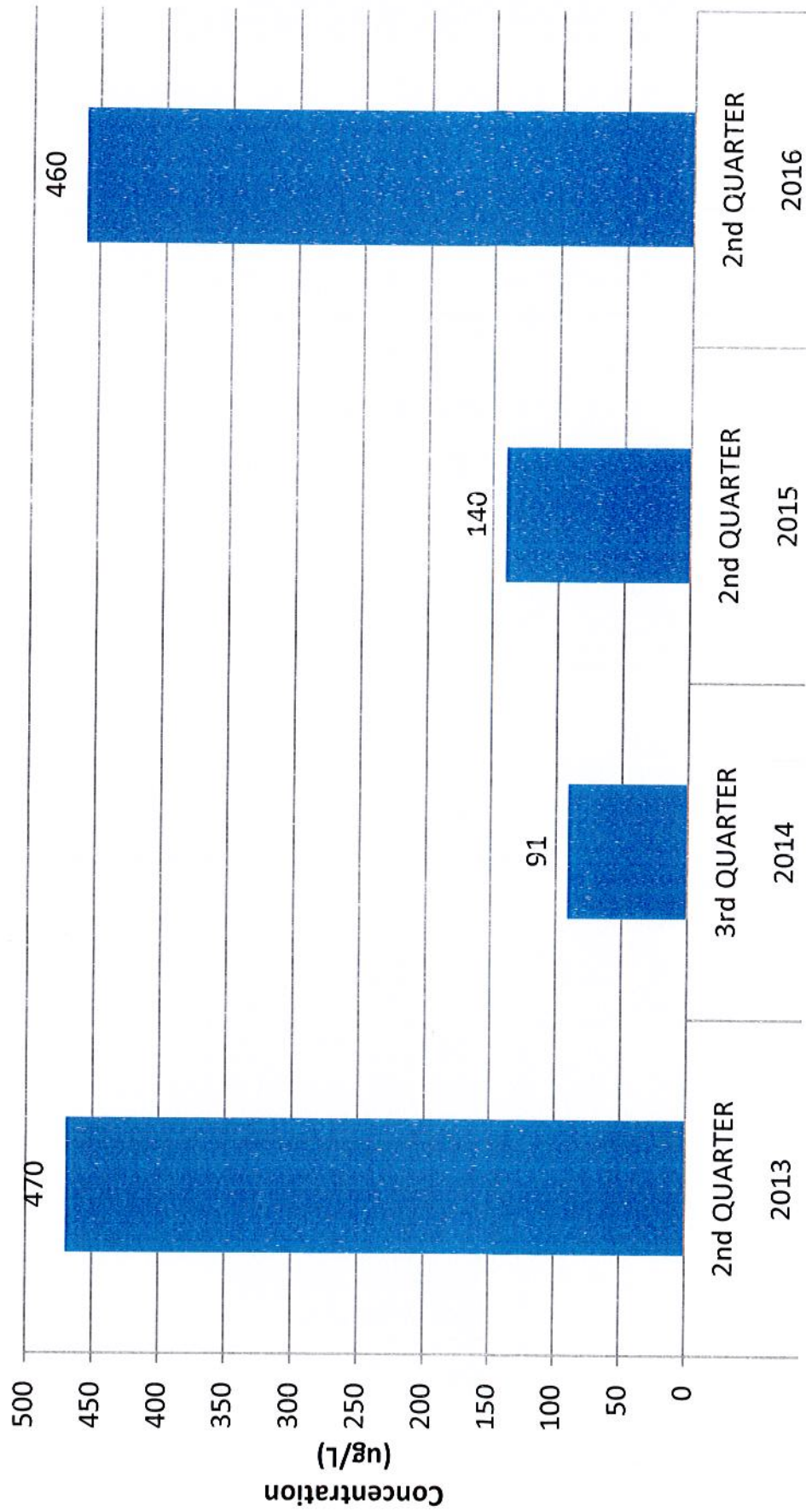




# New Windsor Landfill Quarterly Monitoring Reports

## MW 3D

### Manganese

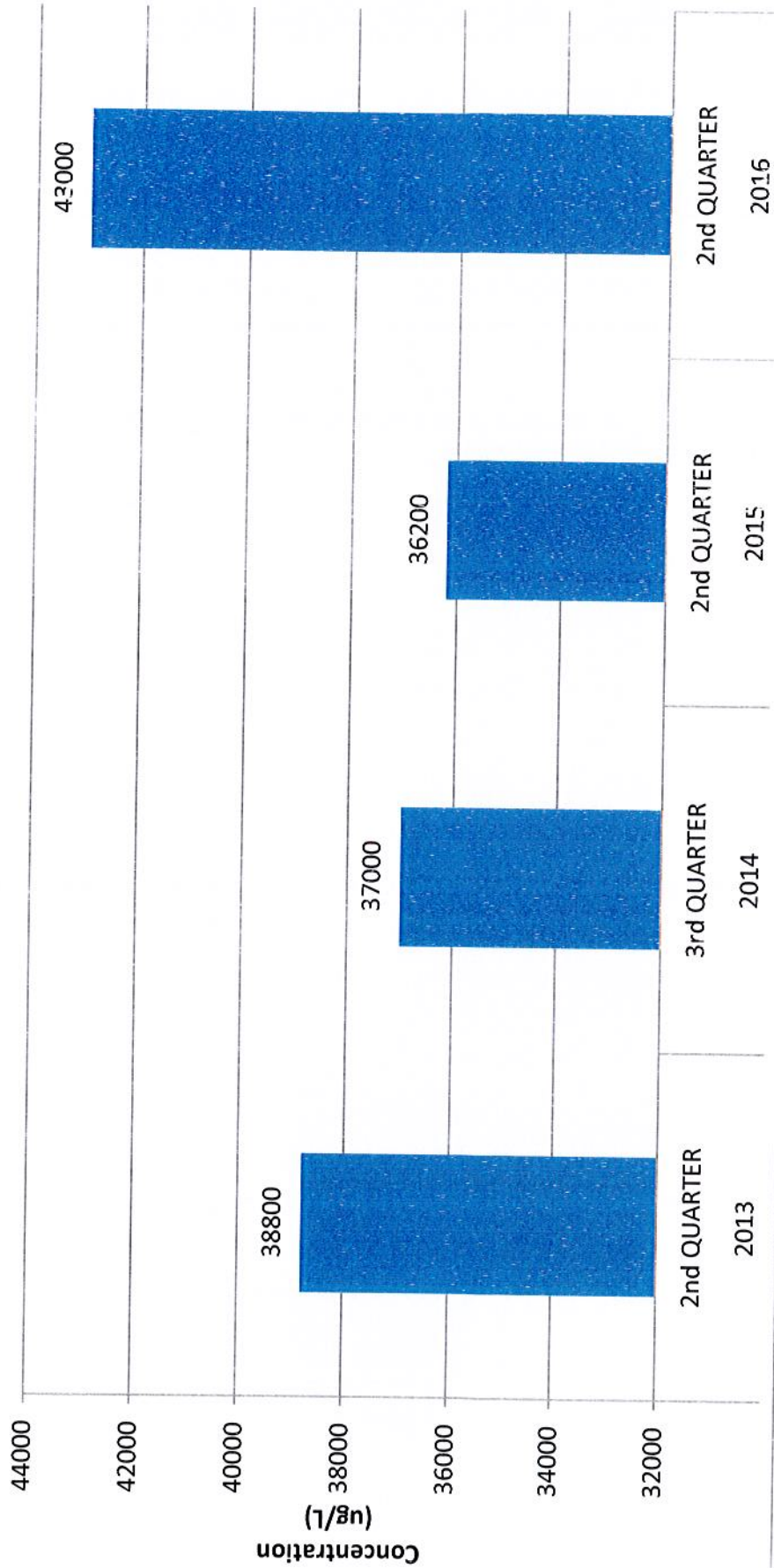




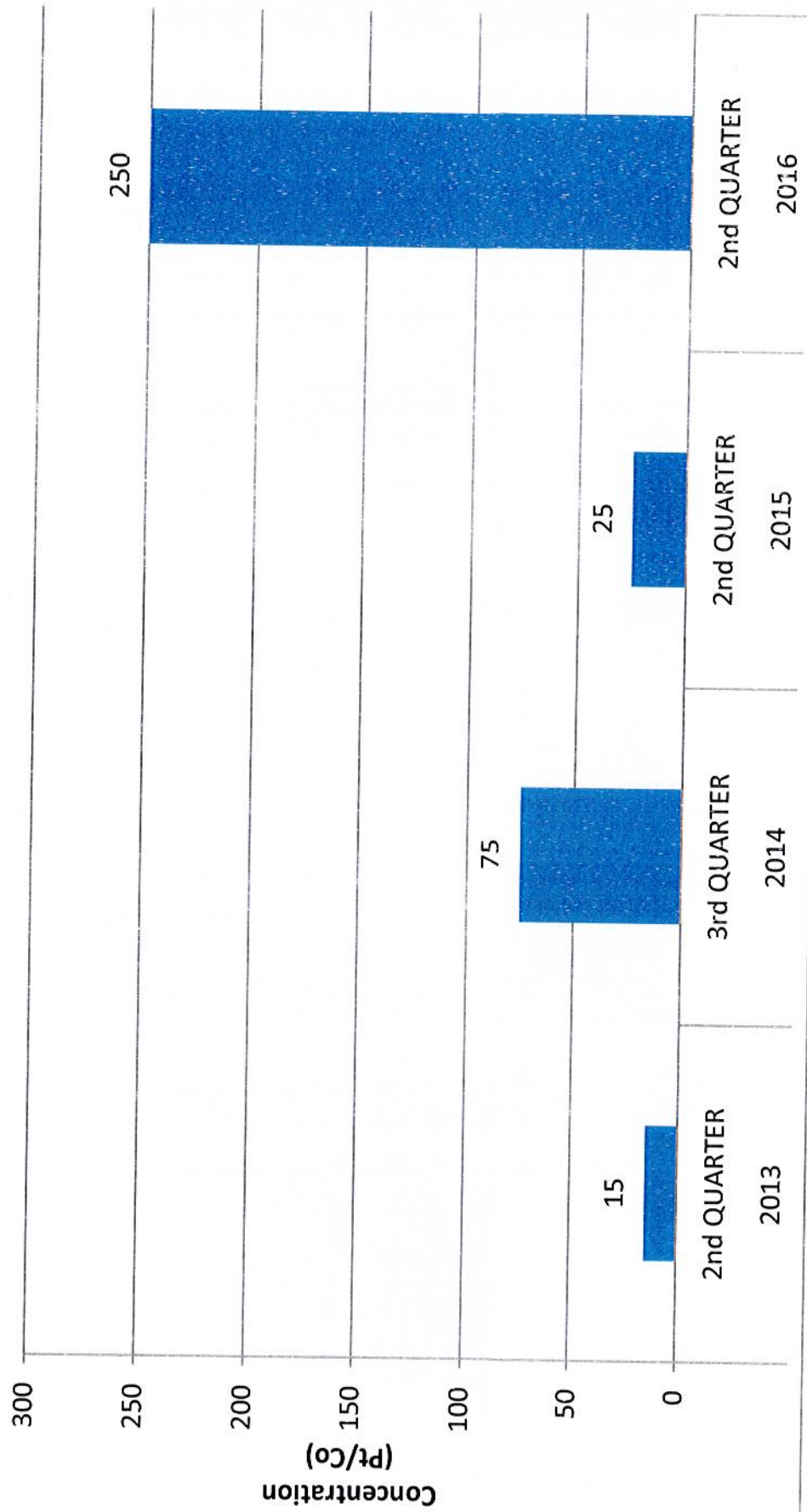
# New Windsor Landfill Quarterly Monitoring Reports

## MW 3D

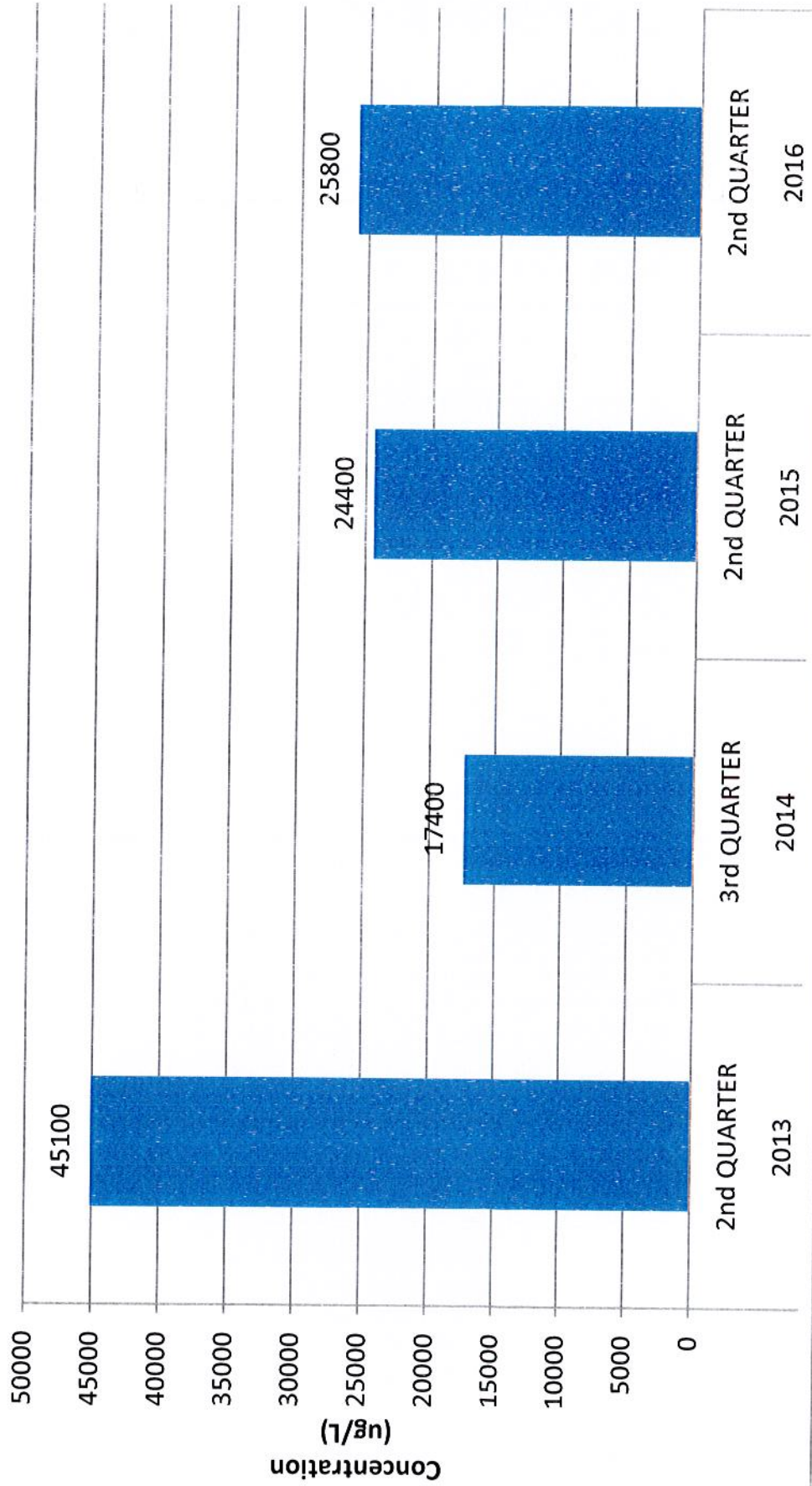
### Sodium



# New Windsor Landfill Quarterly Monitoring Reports MW 3S Color

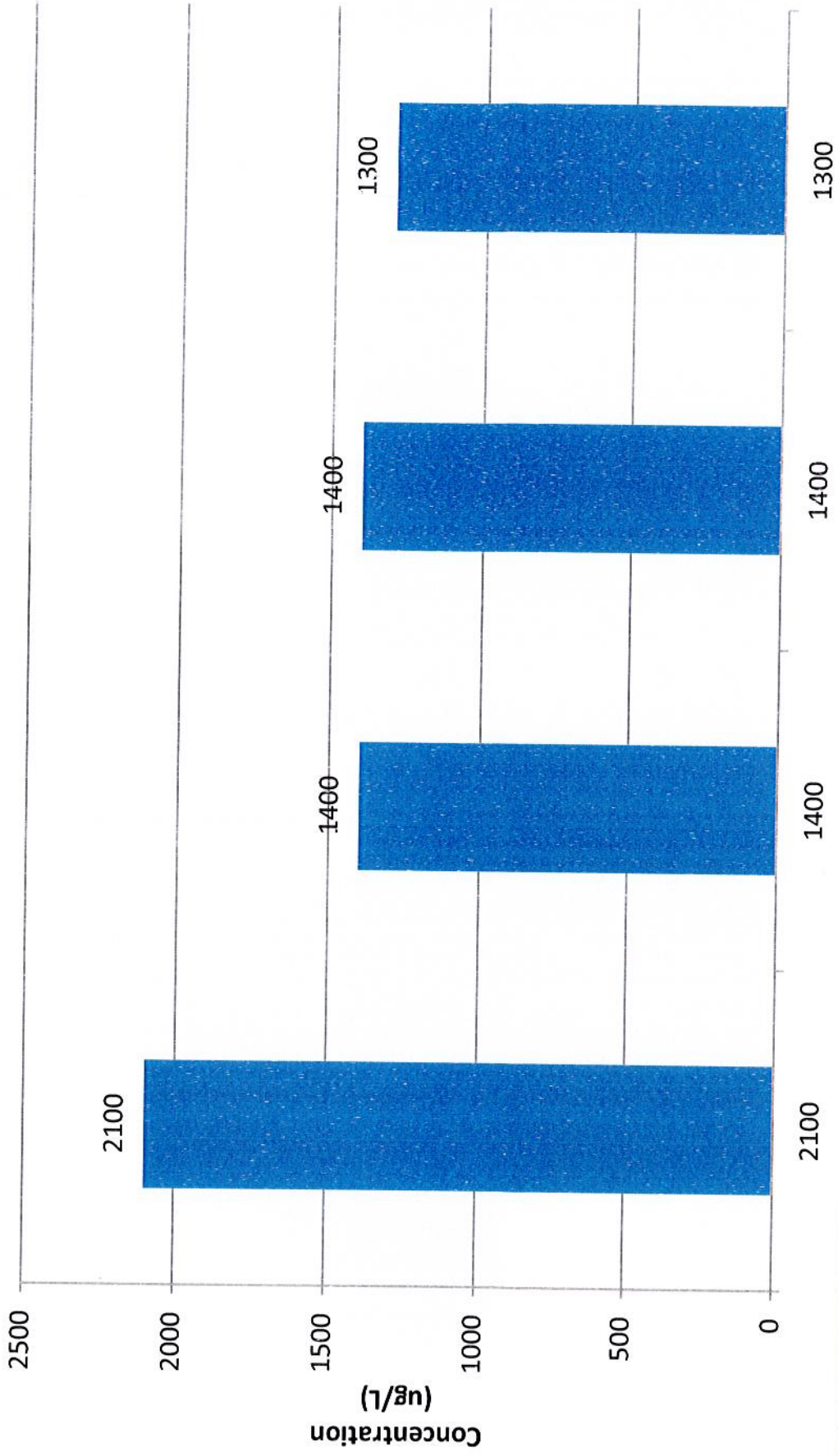


**New Windsor Landfill Quarterly Monitoring Reports**  
**MW 3S**  
**Iron**

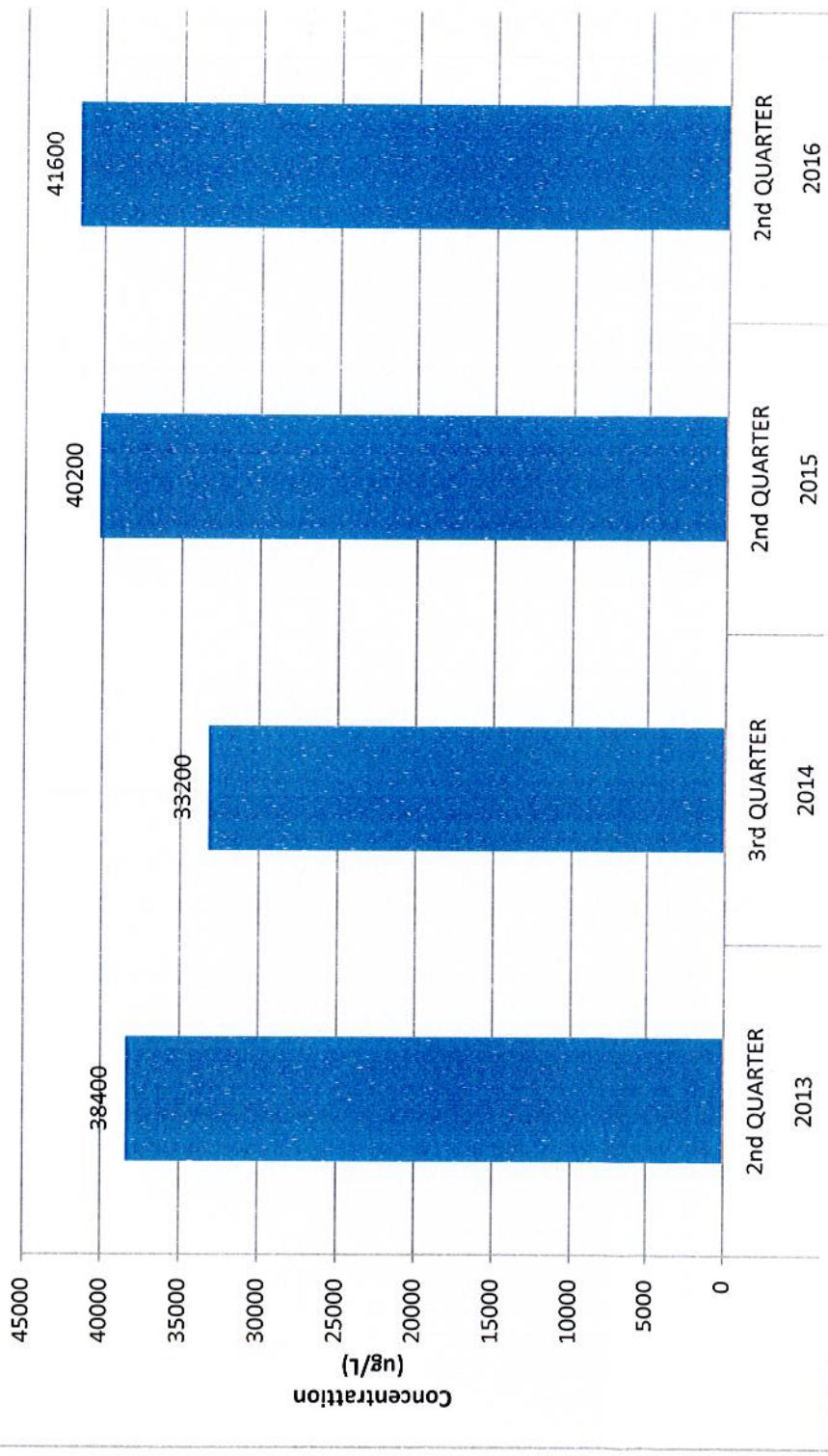




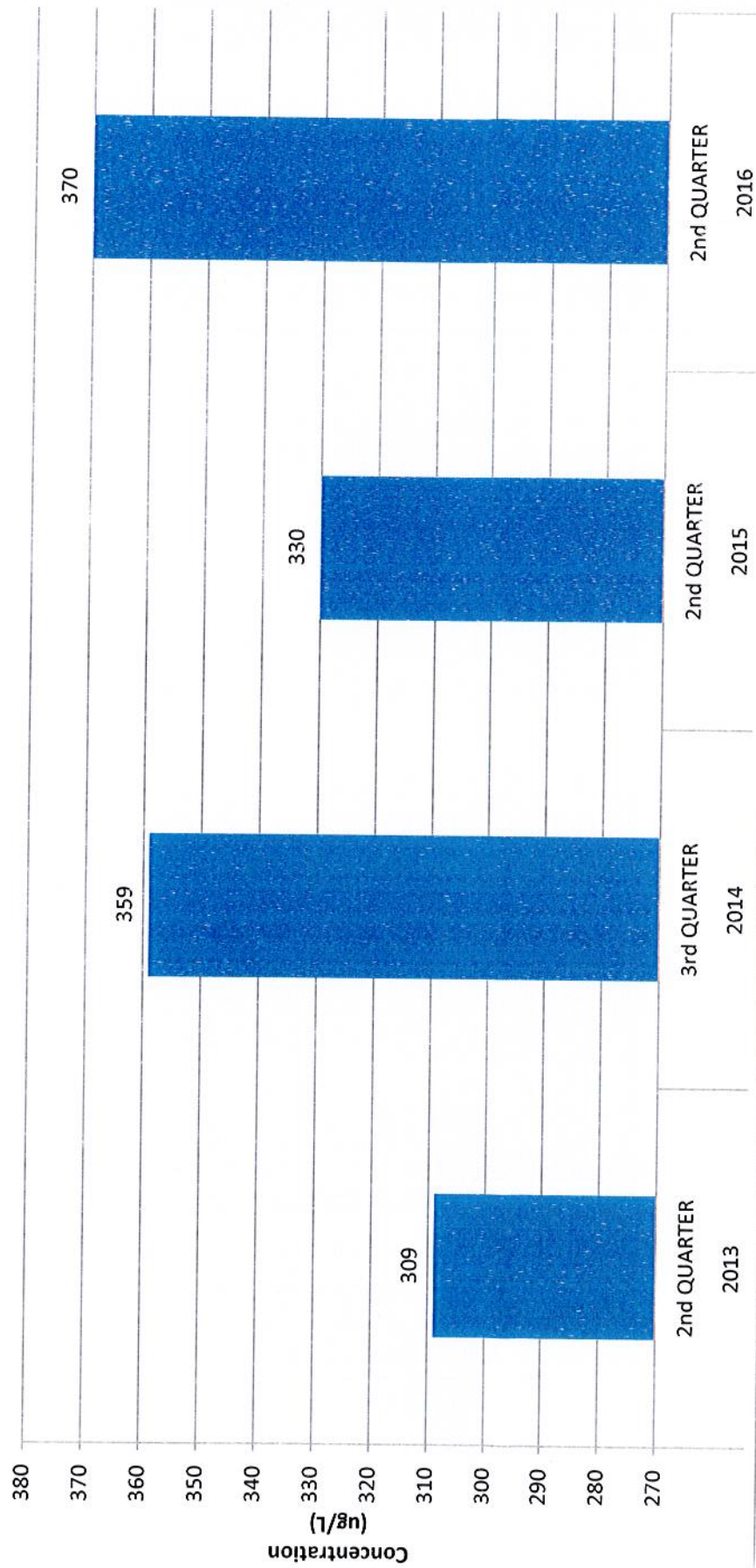
**New Windsor Landfill Quarterly Monitoring Reports**  
**MW 3S**  
**Manganese**



**New Windsor Landfill Quarterly Monitoring Reports  
MW 3S  
Sodium**

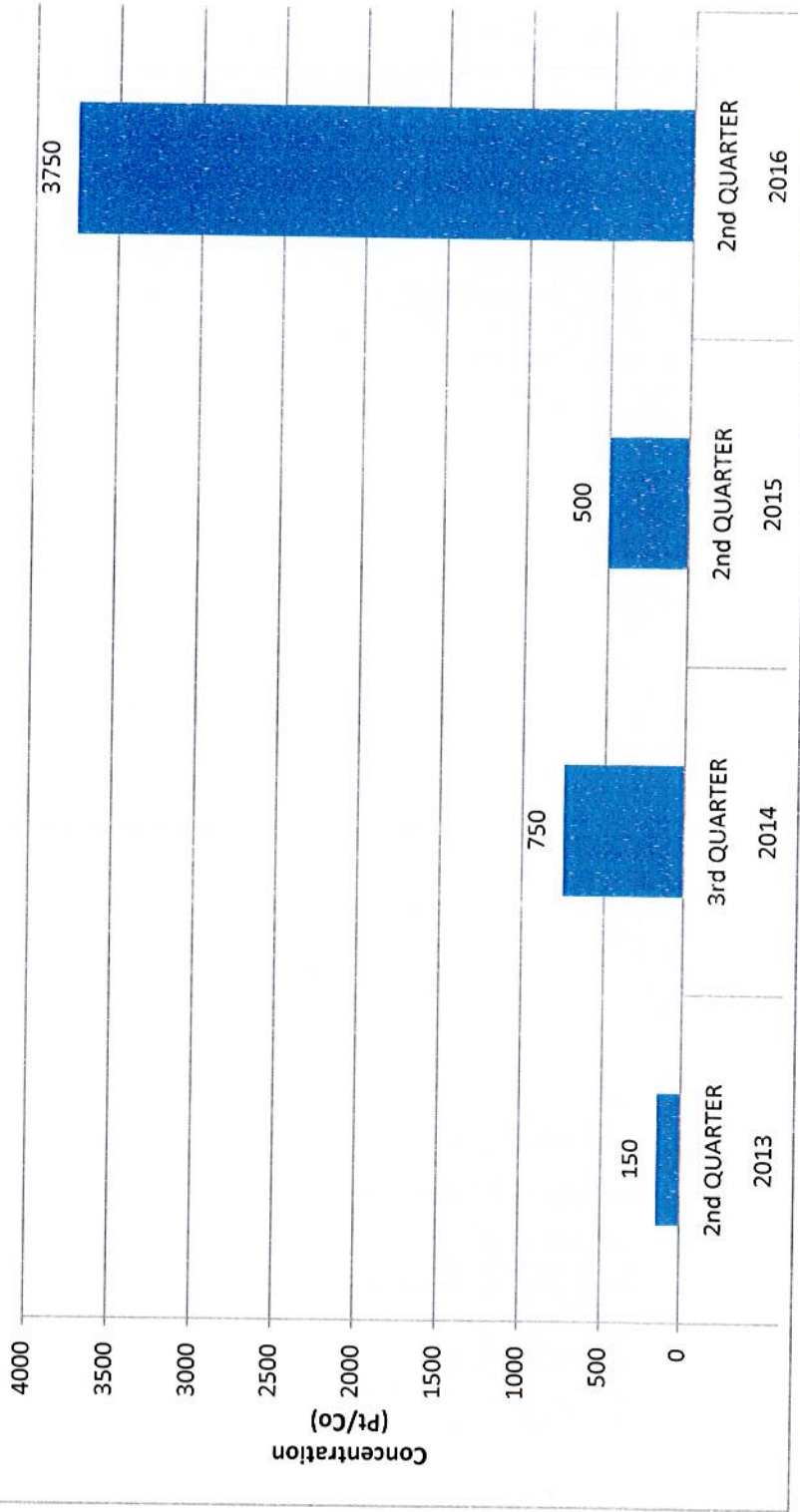


**New Windsor Landfill Quarterly Monitoring Reports**  
**MW 4S**  
**Chloride**

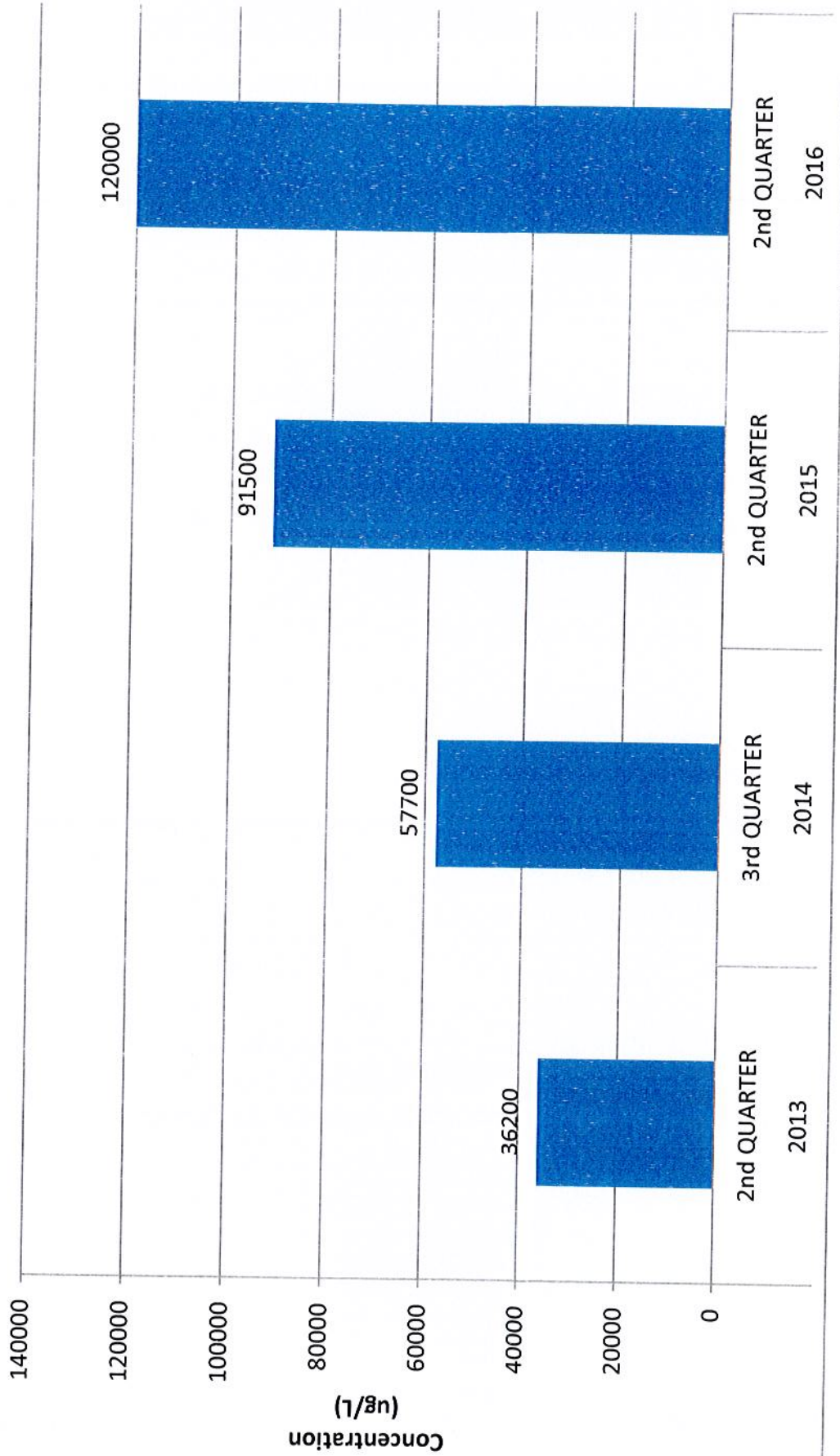




**New Windsor Landfill Quarterly Monitoring Reports  
MW 4S  
Color**

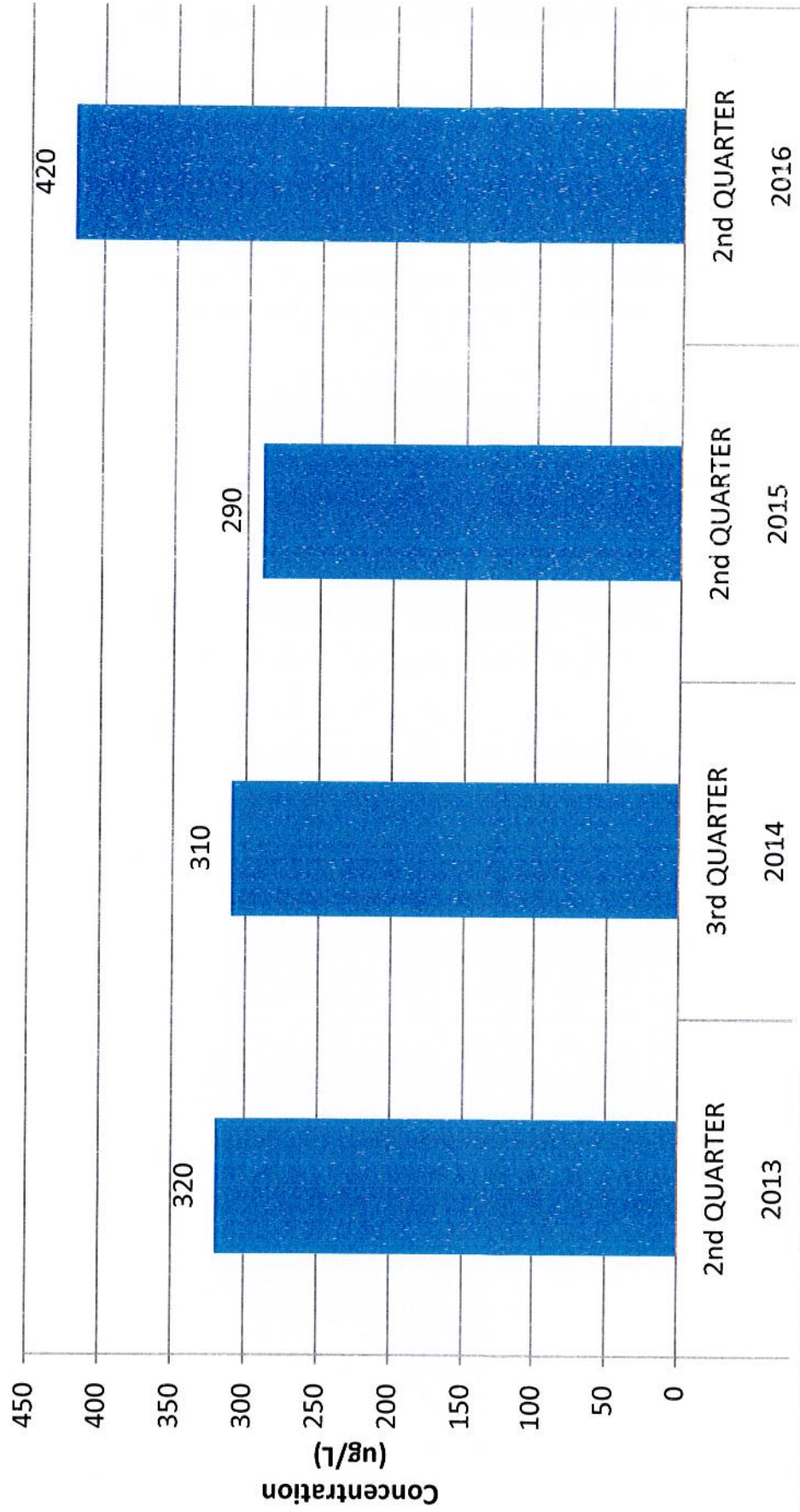


# New Windsor Landfill Quarterly Monitoring Reports MW 4S Iron





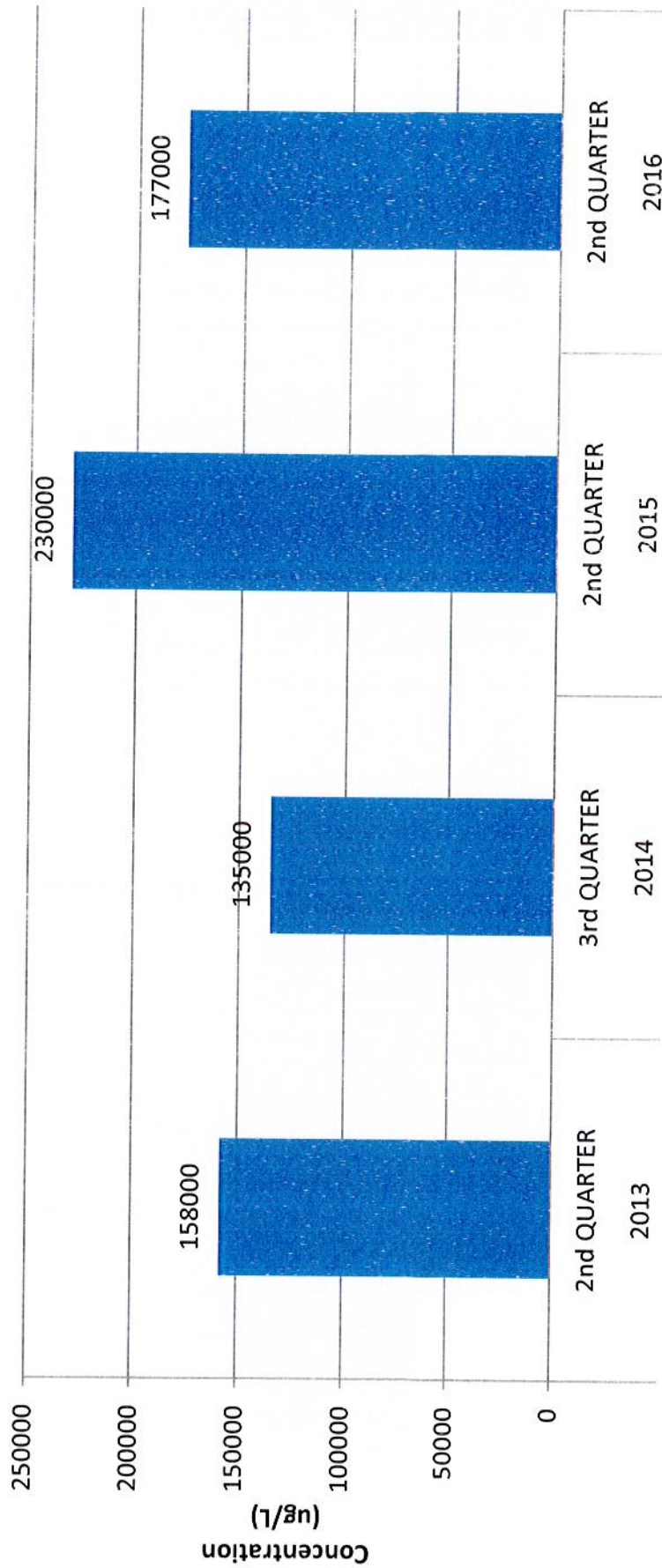
**New Windsor Landfill Quarterly Monitoring Reports  
MW 4S  
Manganese**



# New Windsor Landfill Quarterly Monitoring Reports

## MW 4S

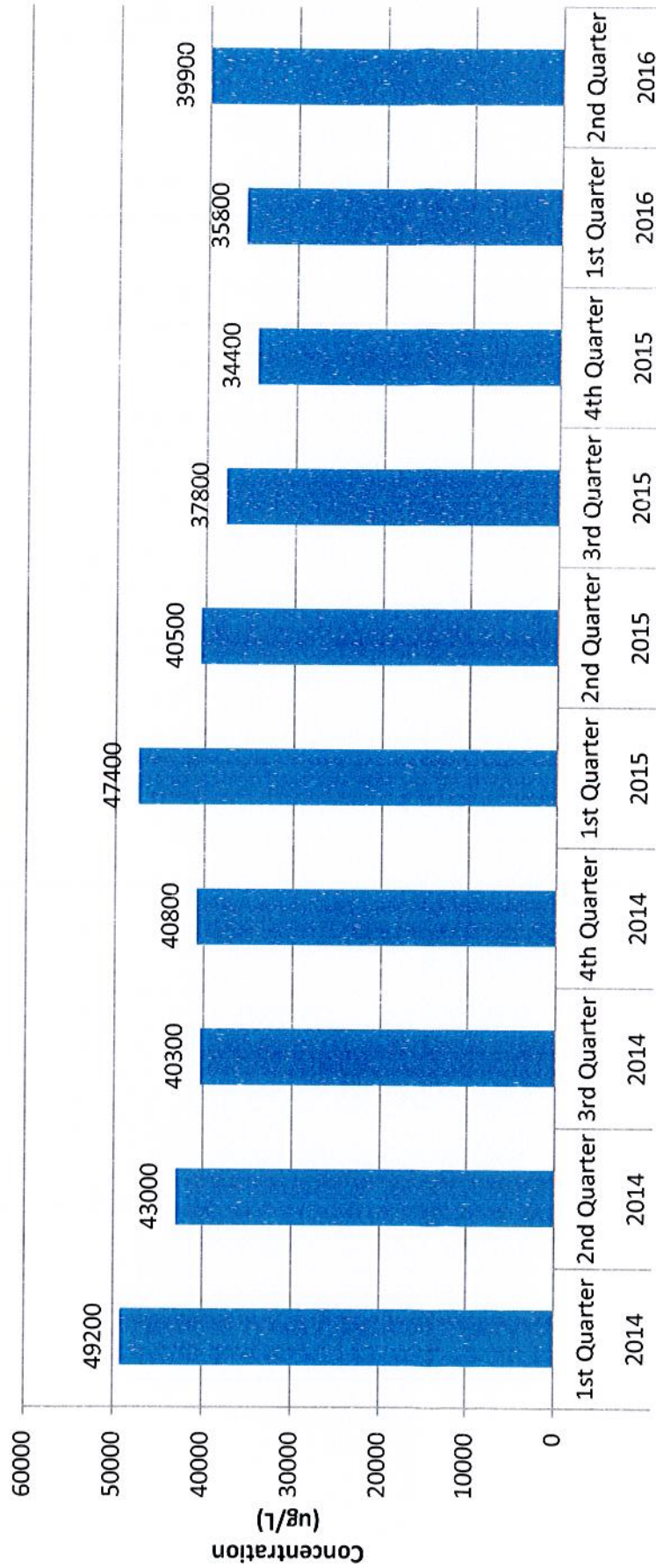
### Sodium



# New Windsor Landfill Quarterly Monitoring Reports

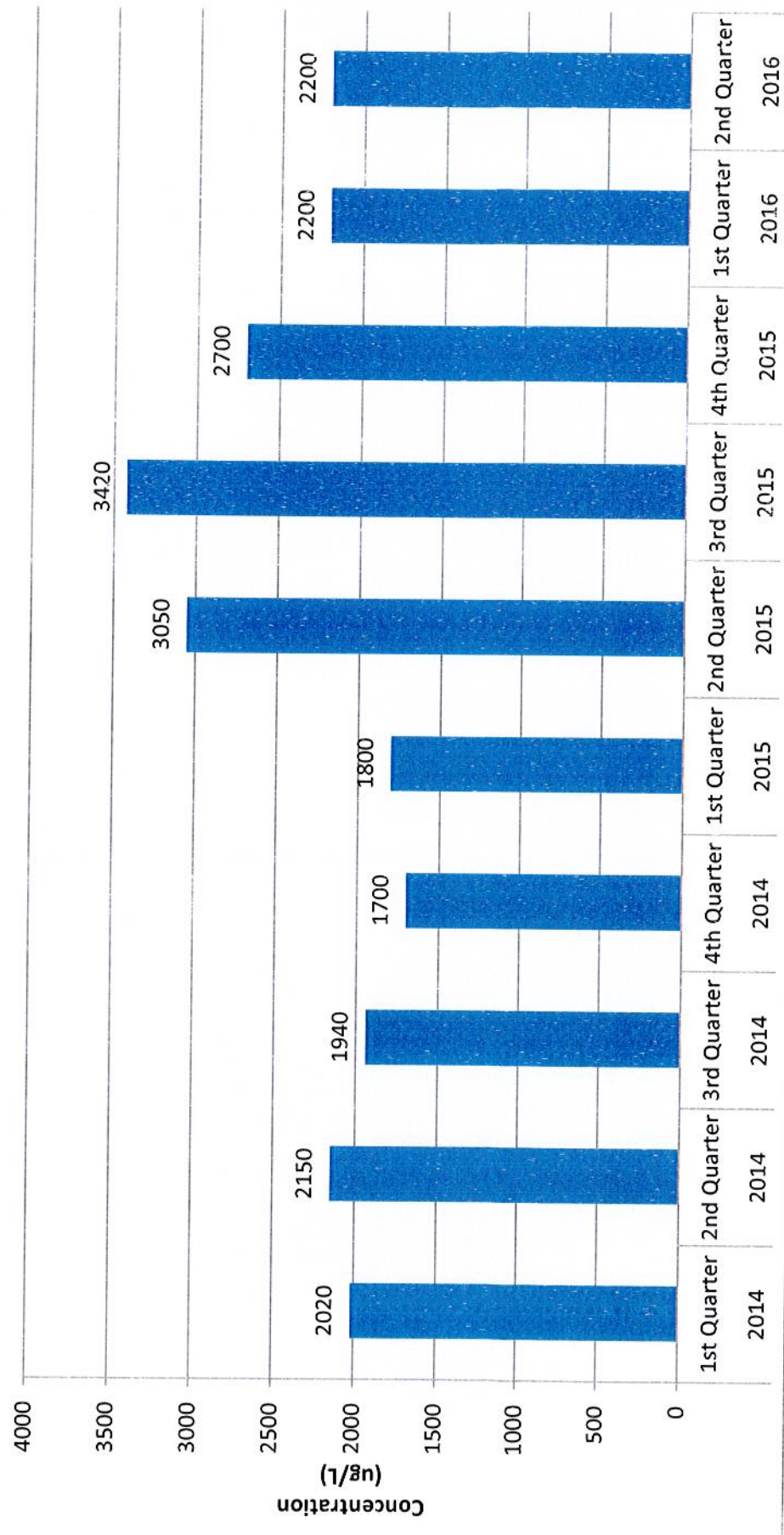
## MW 6D

### Sodium

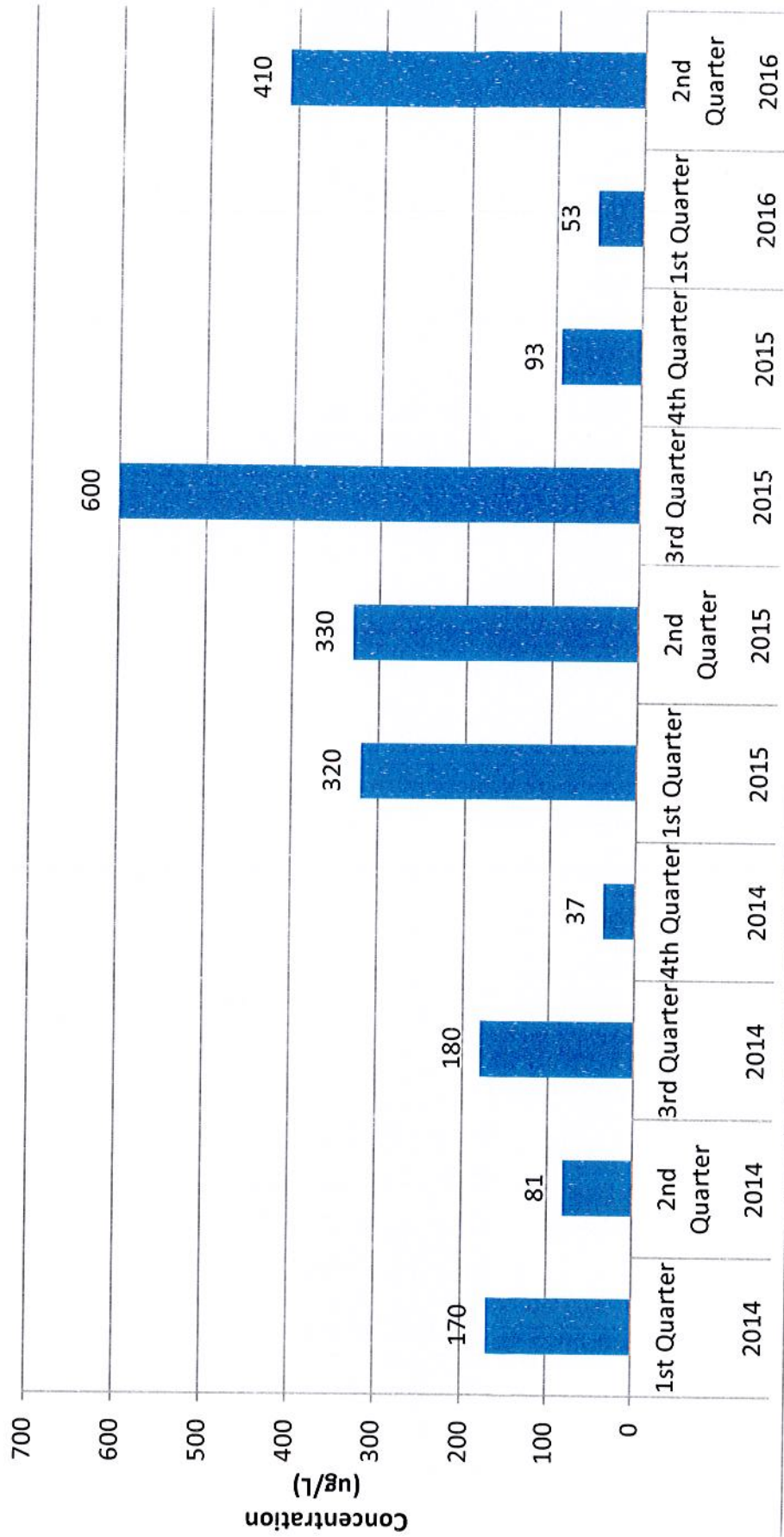




**New Windsor Landfill Quarterly Monitoring Reports  
MW 6S  
Chloride**



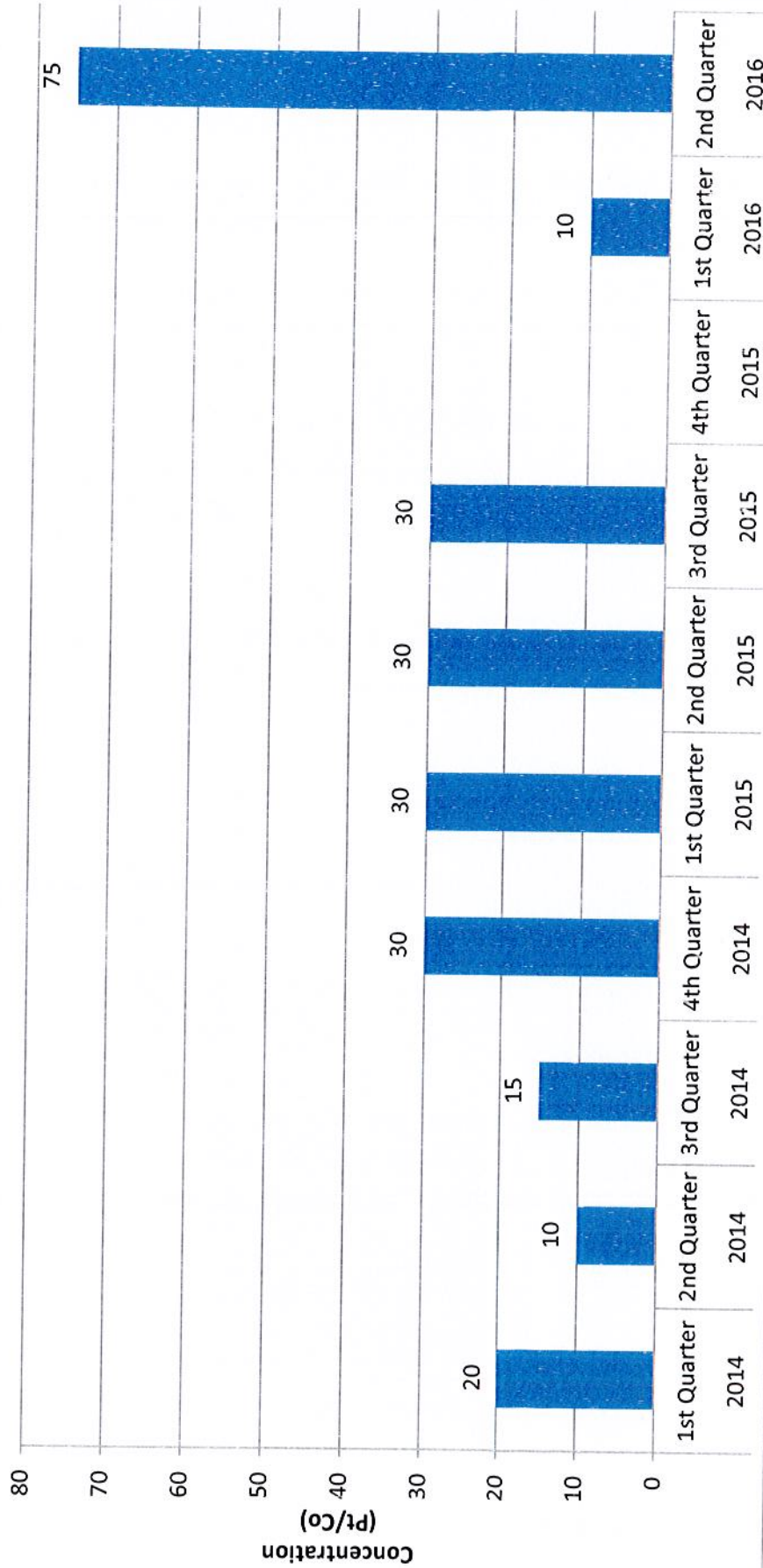
**New Windsor Landfill Quarterly Monitoring Reports  
MW 6S  
Chromium**



# New Windsor Landfill Quarterly Monitoring Reports

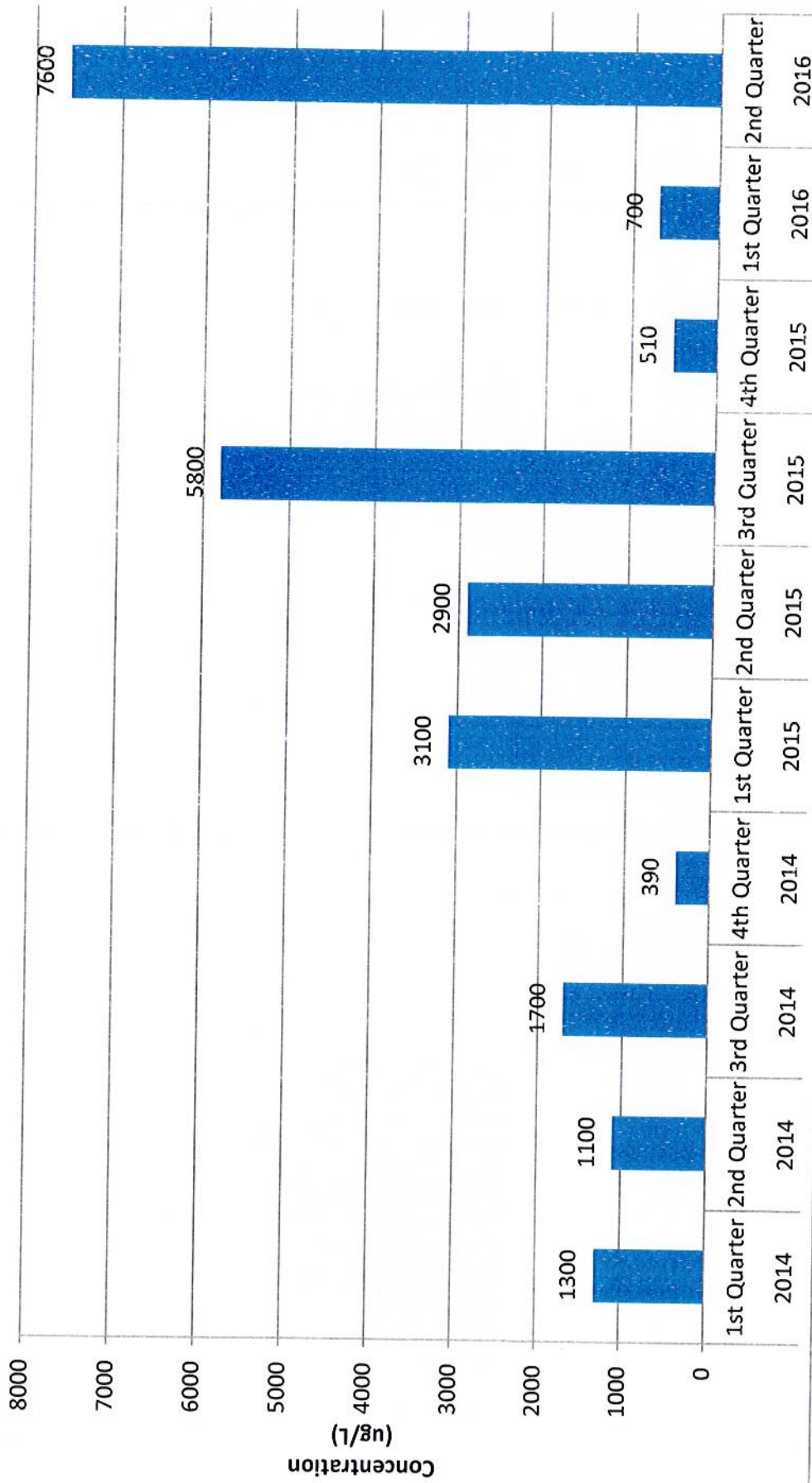
MW 6S

Color





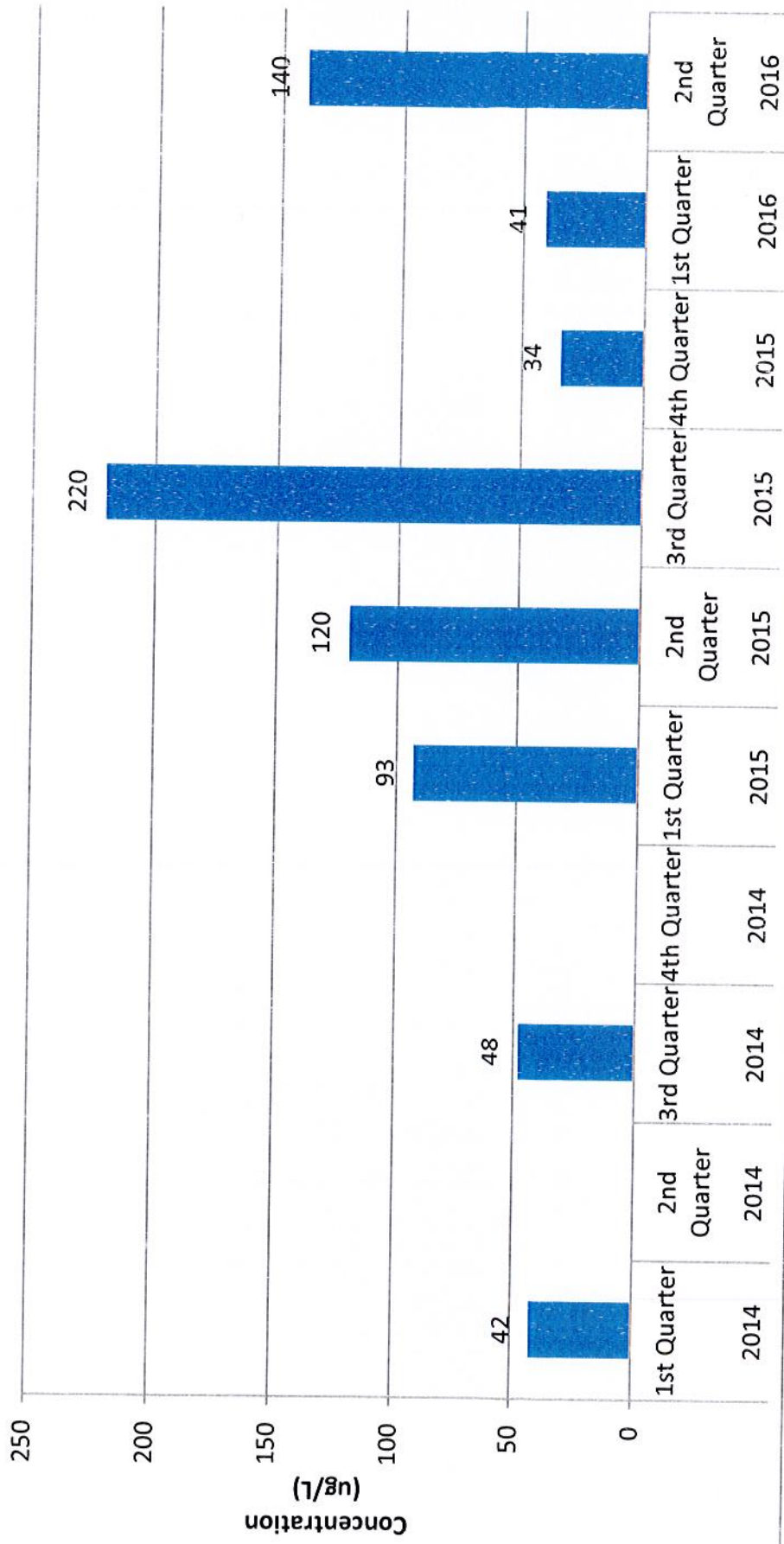
**New Windsor Landfill Quarterly Monitoring Reports  
MW 6S  
Iron**



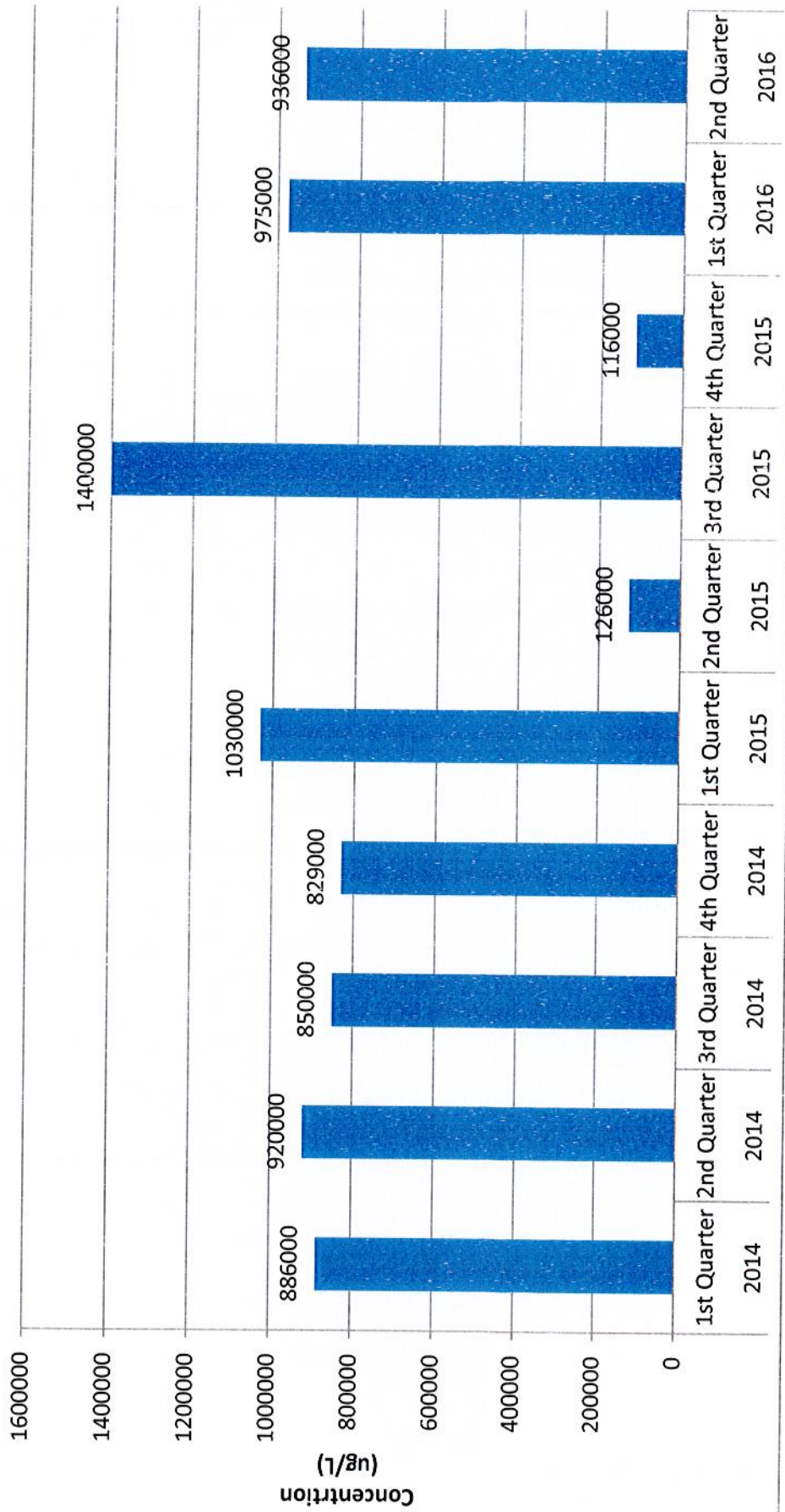


# New Windsor Landfill Quarterly Monitoring Reports

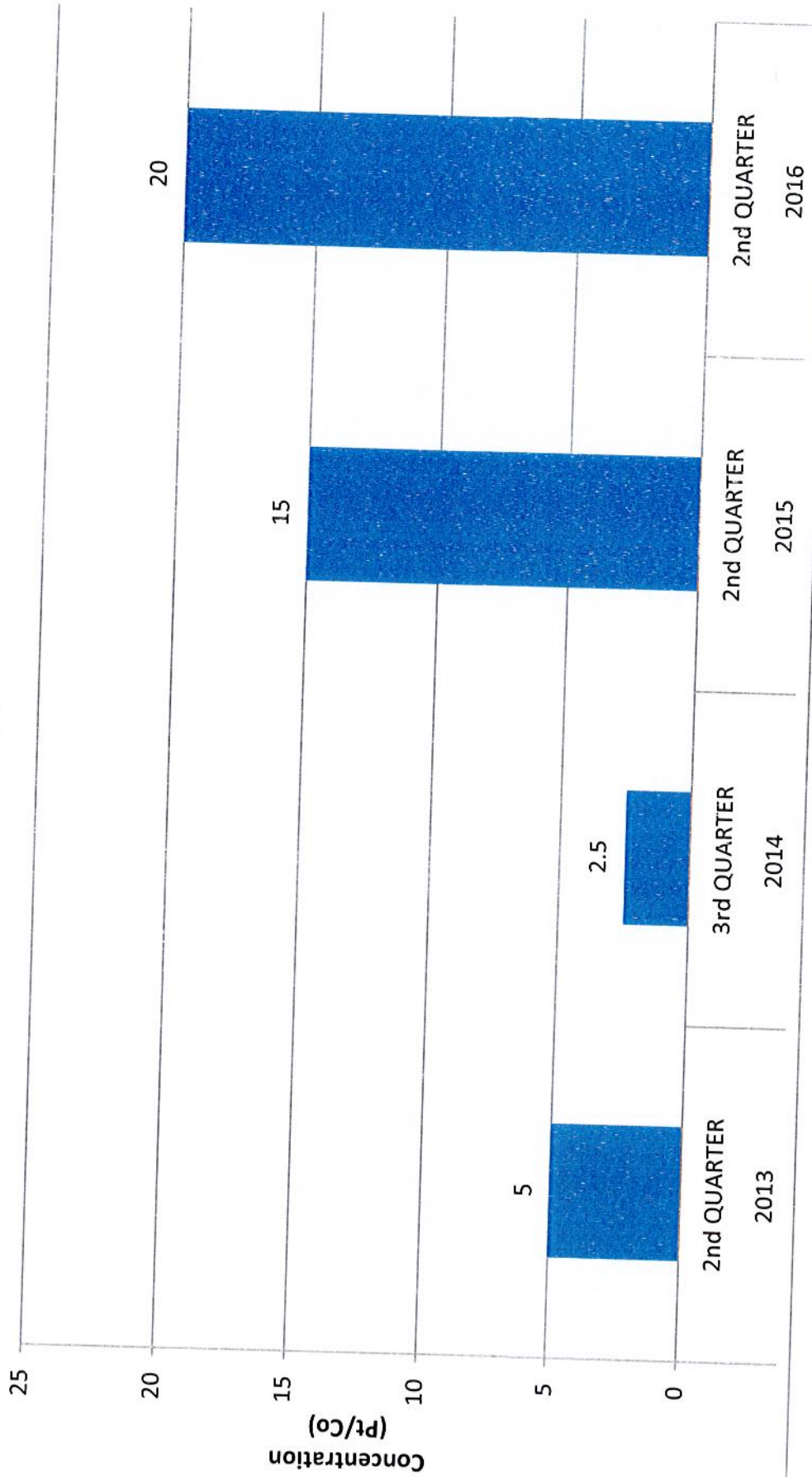
MW 6S  
Nickel



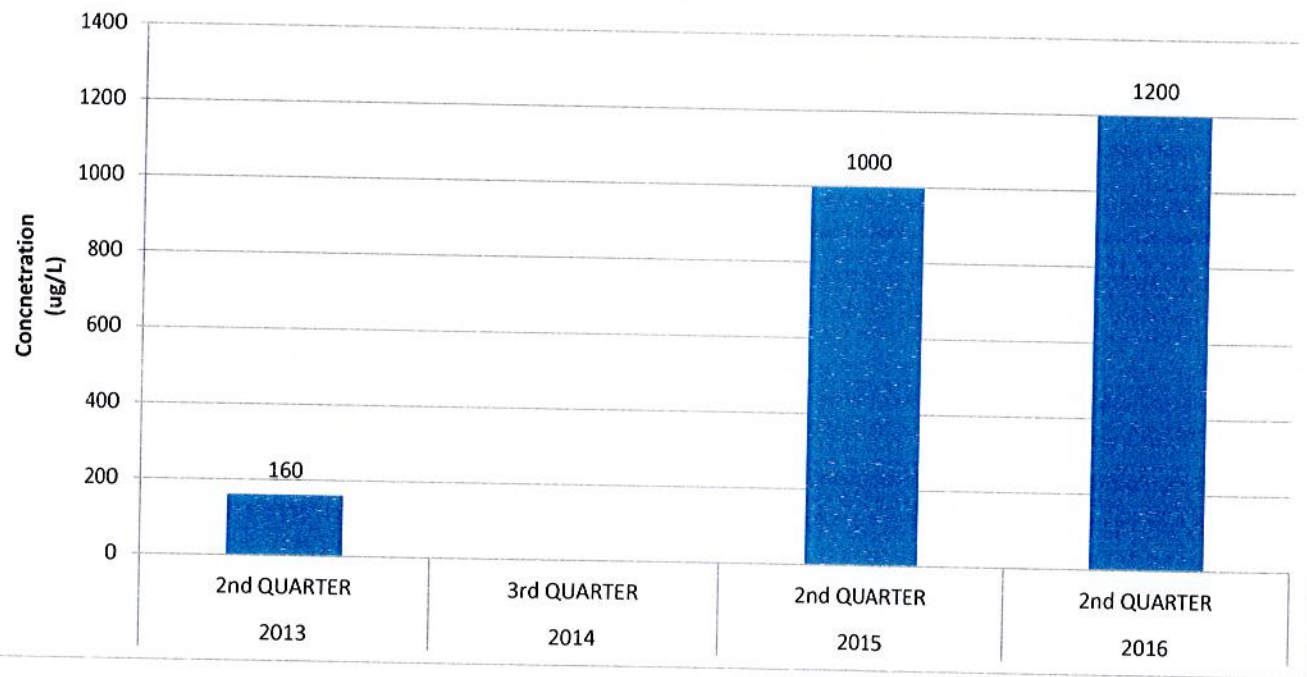
**New Windsor Landfill Quarterly Monitoring Reports  
MW 6S  
Sodium**



**New Windsor Landfill Quarterly Monitoring Reports  
MW 7D  
Color**

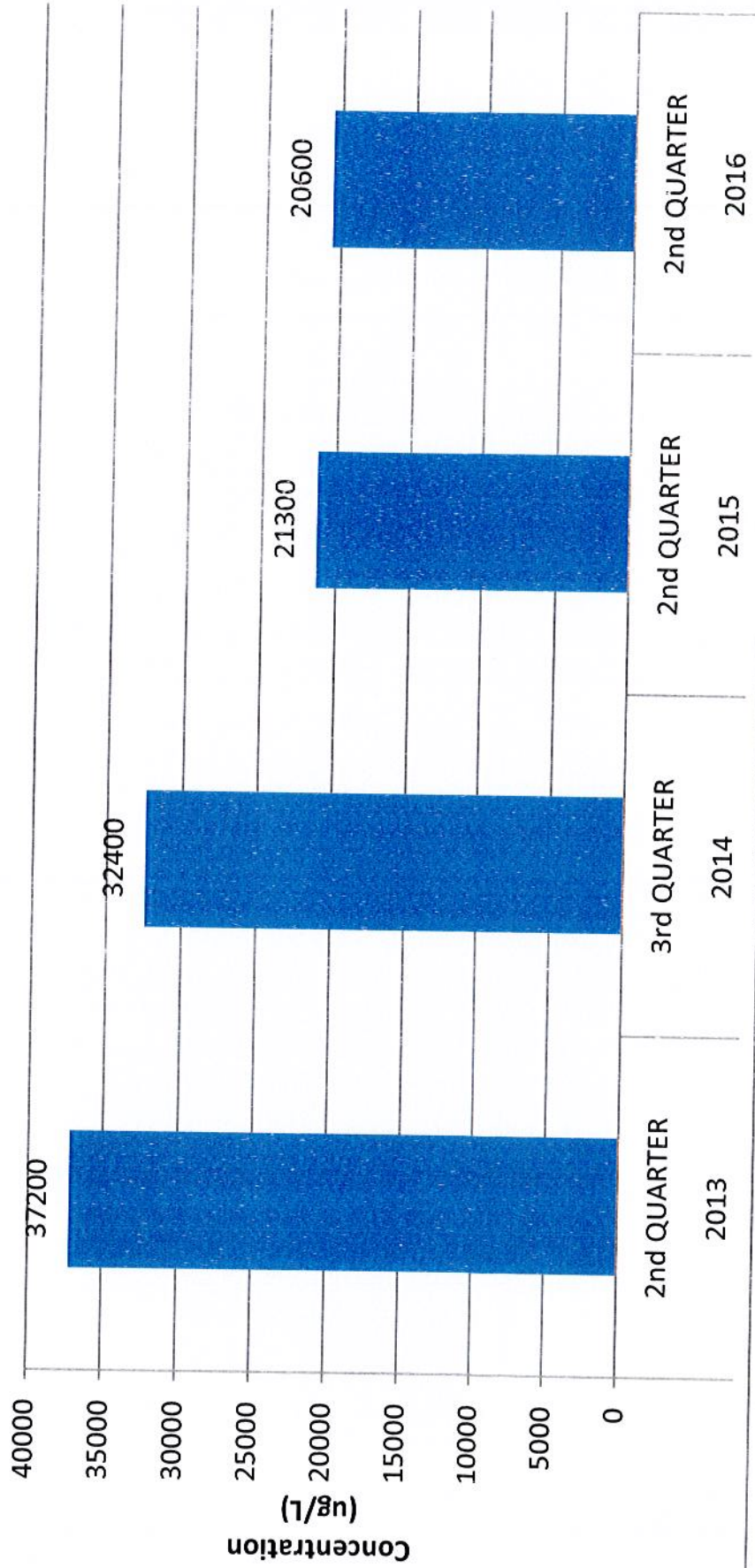


**New Windsor Landfill Quarterly Monitoring Reports  
MW 7D  
Iron**





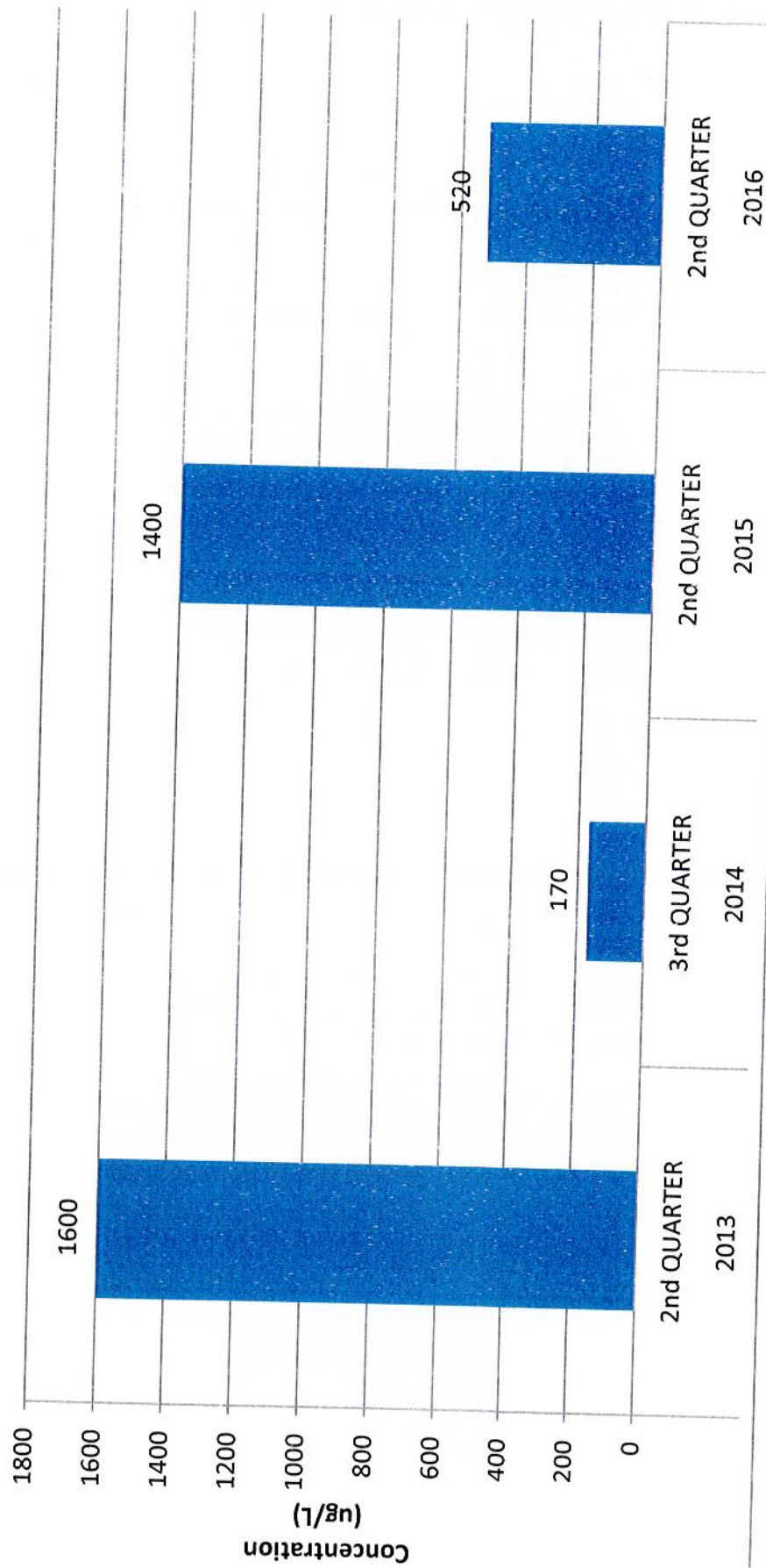
**New Windsor Landfill Quarterly Monitoring Reports**  
**MW 7D**  
**Sodium**



# New Windsor Landfill Quarterly Monitoring Reports

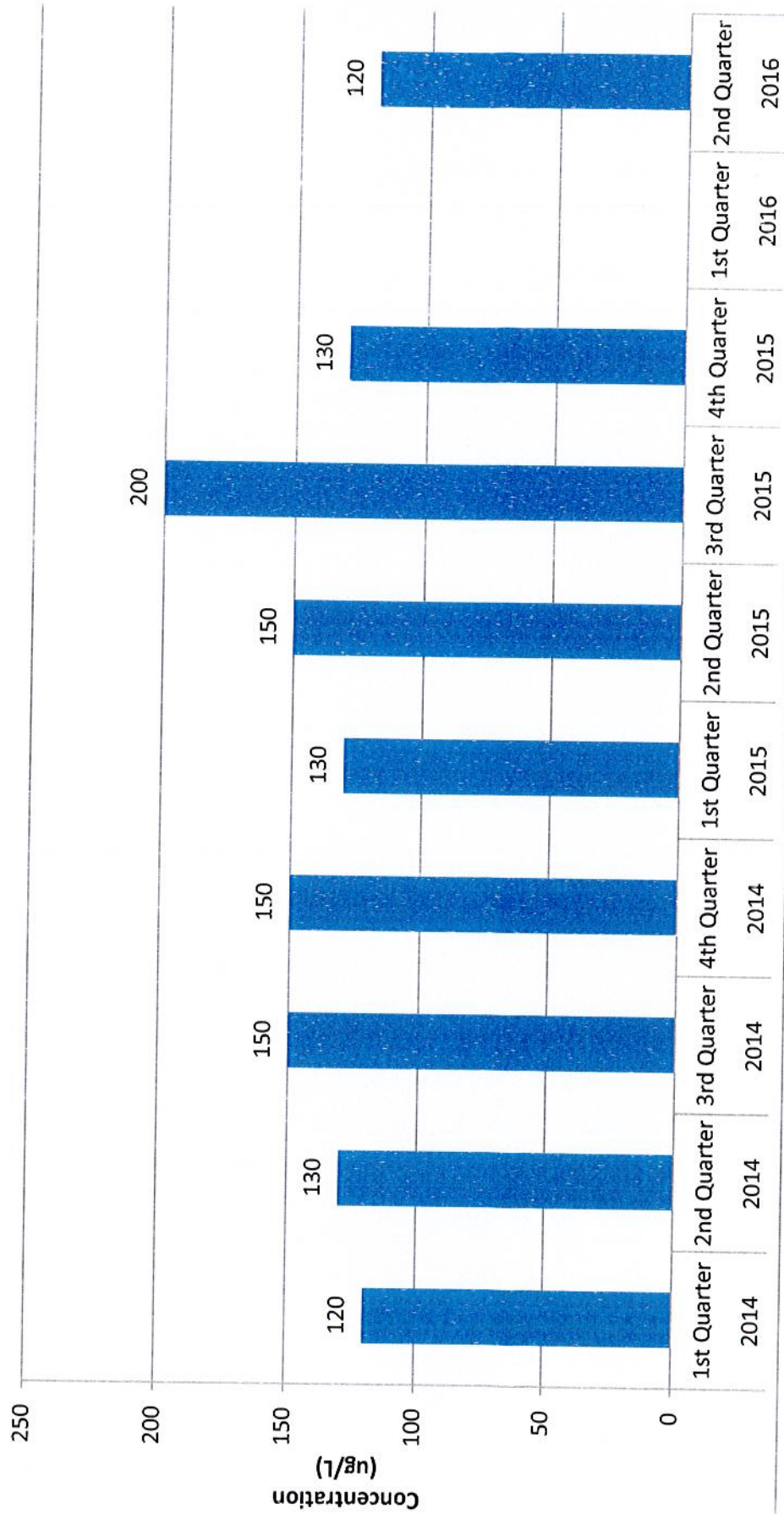
## MW 8D

### Iron

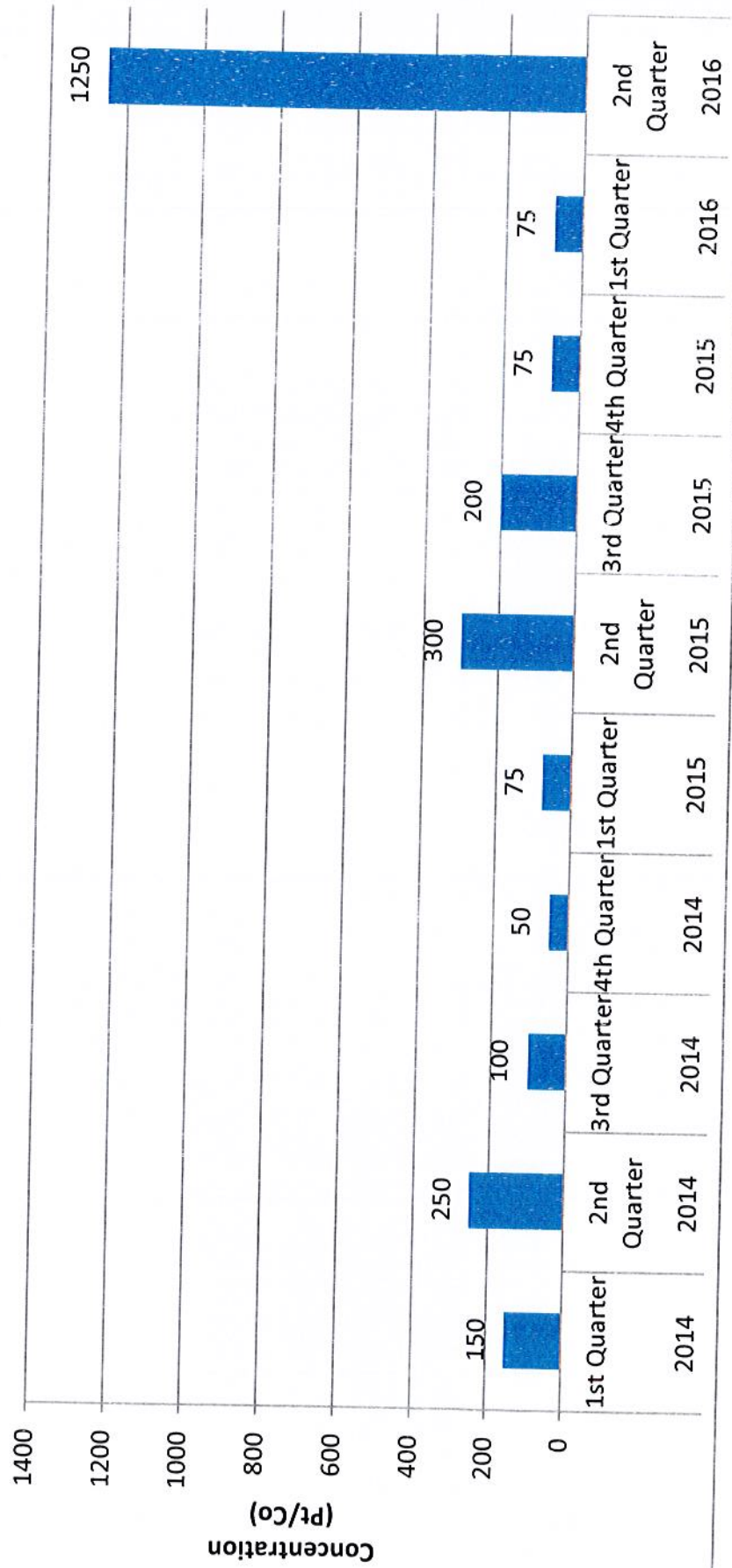




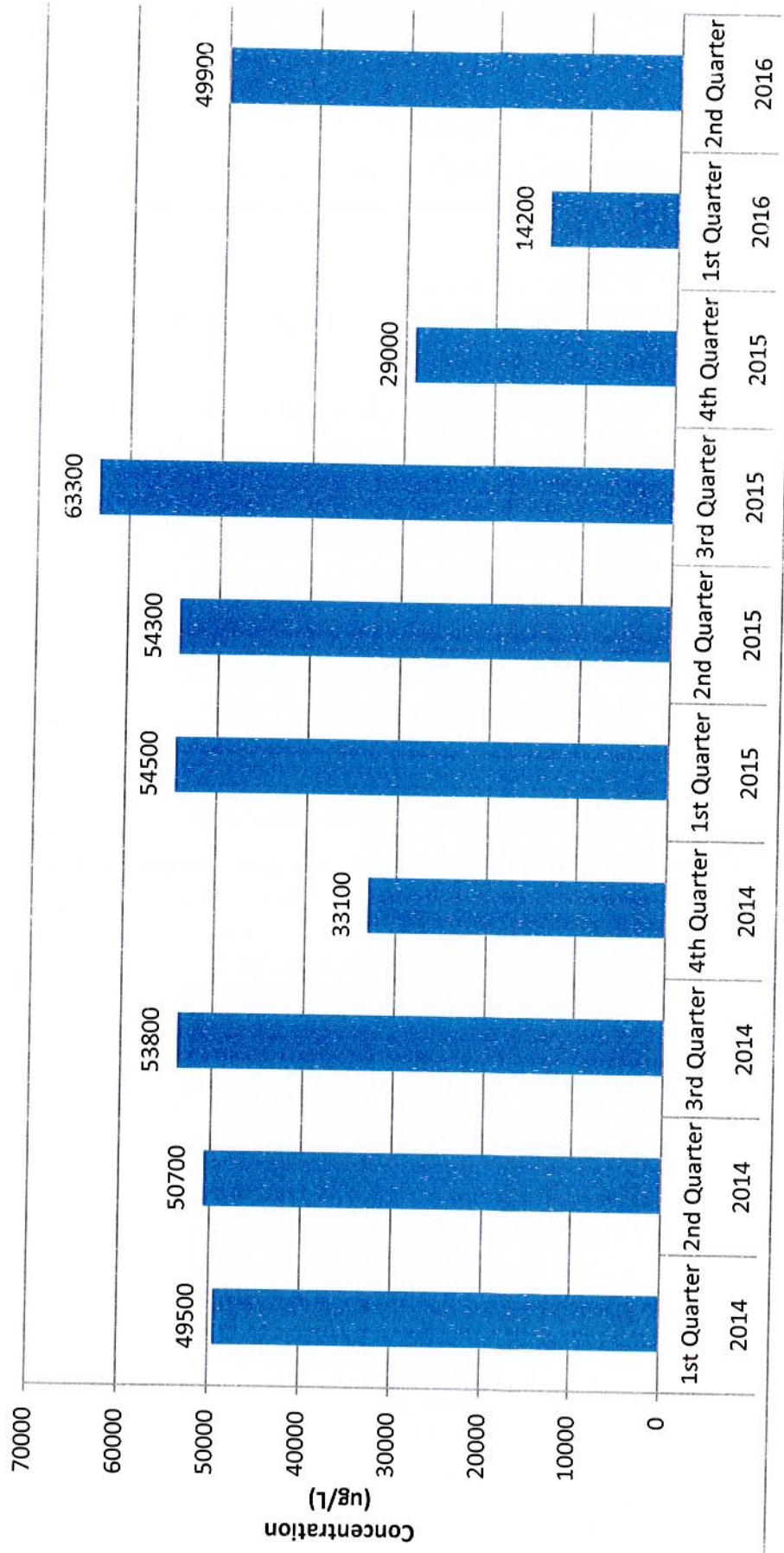
**New Windsor Landfill Quarterly Monitoring Reports  
MW 9S  
Boron**



**New Windsor Landfill Quarterly Monitoring Reports  
MW 9S  
Color**

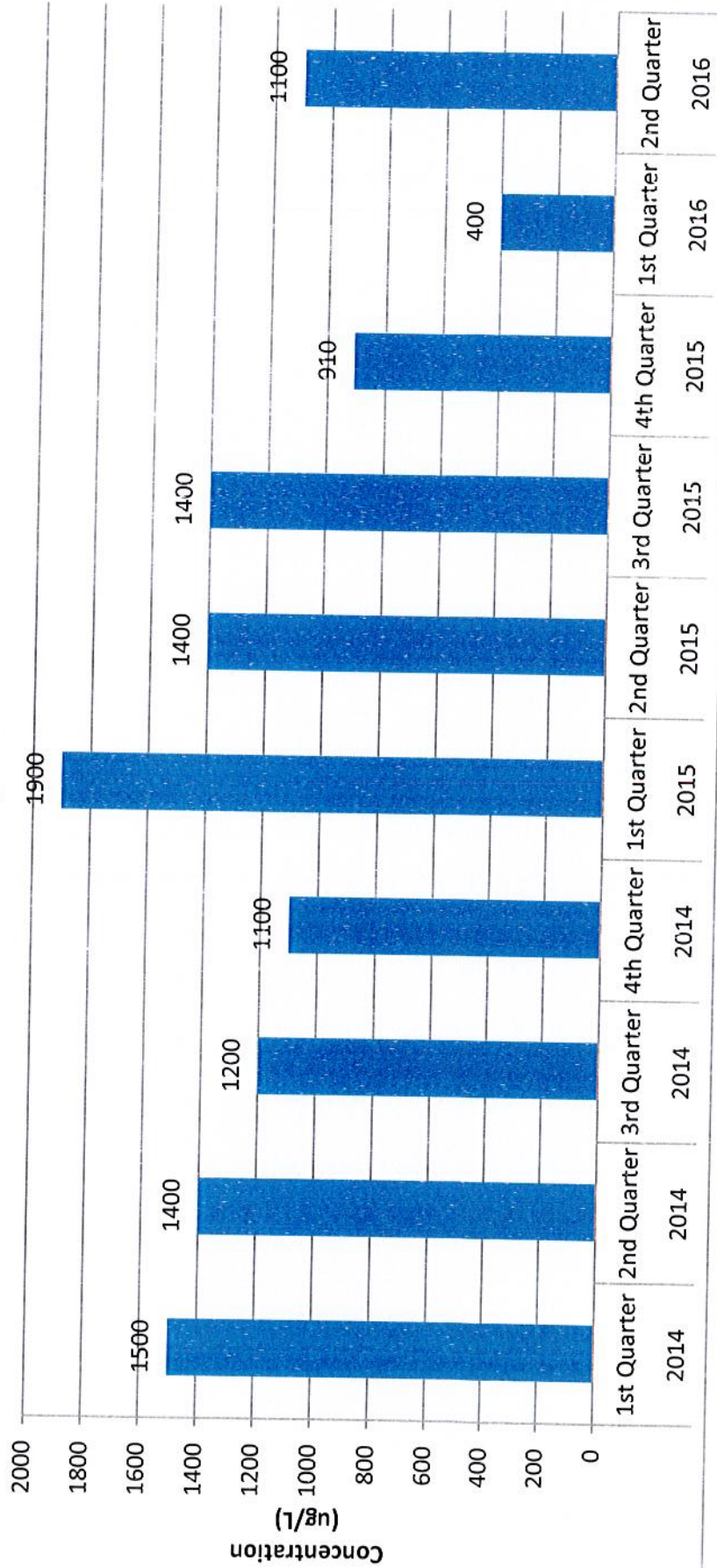


**New Windsor Landfill Quarterly Monitoring Reports  
MW 9S  
Iron**



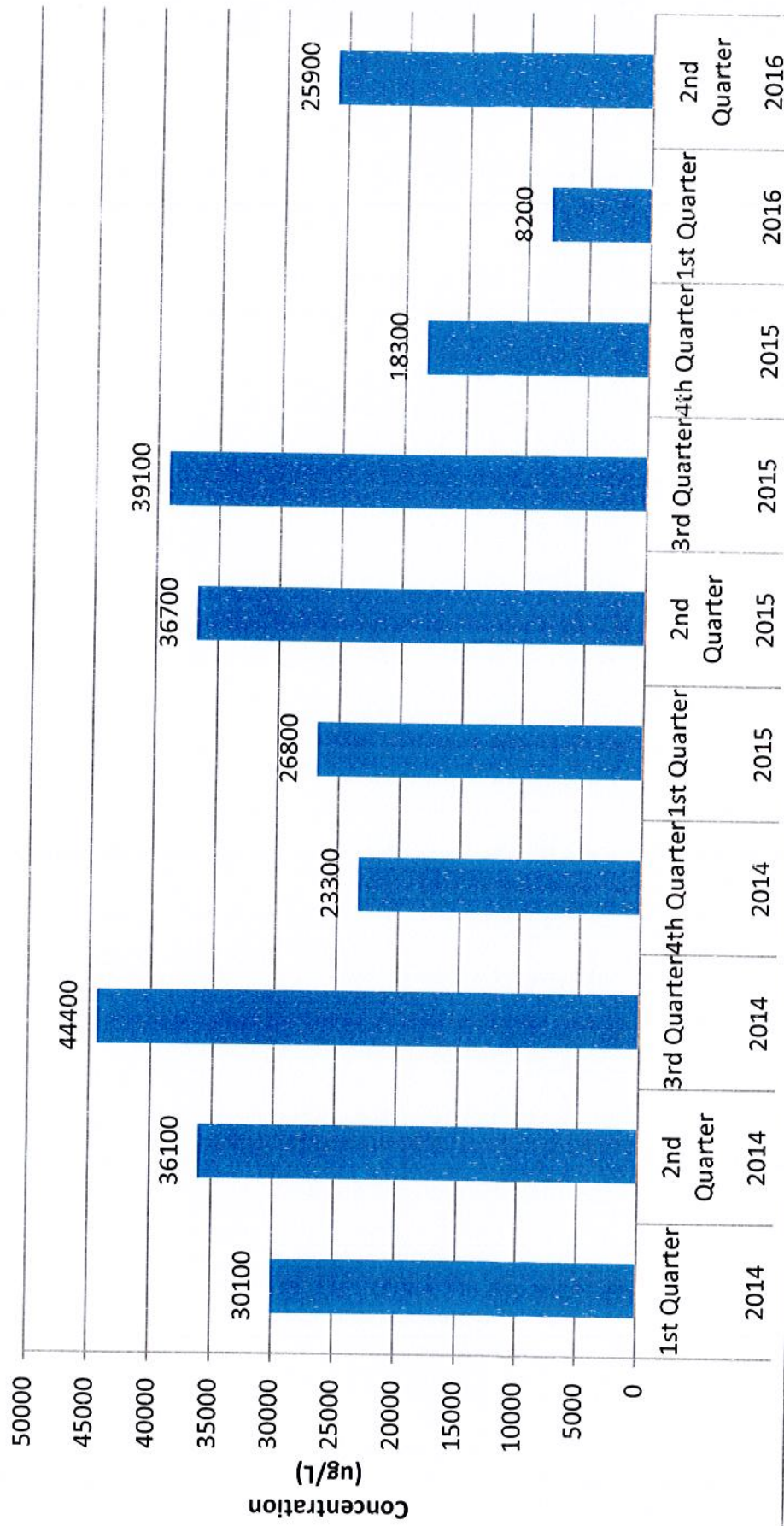


**New Windsor Landfill Quarterly Monitoring Reports  
MW 9S  
Manganese**

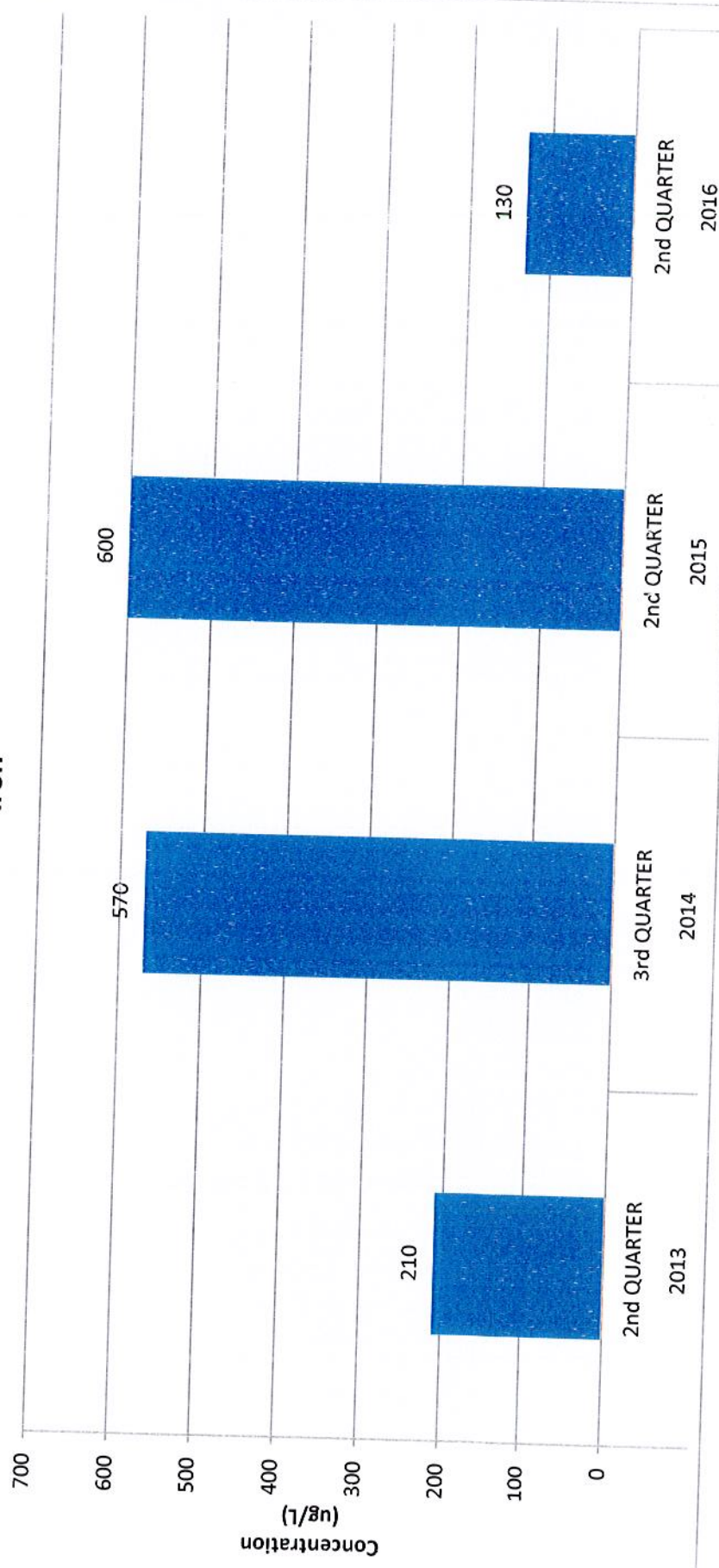


# New Windsor Landfill Quarterly Monitoring Reports

## MW 9S Sodium

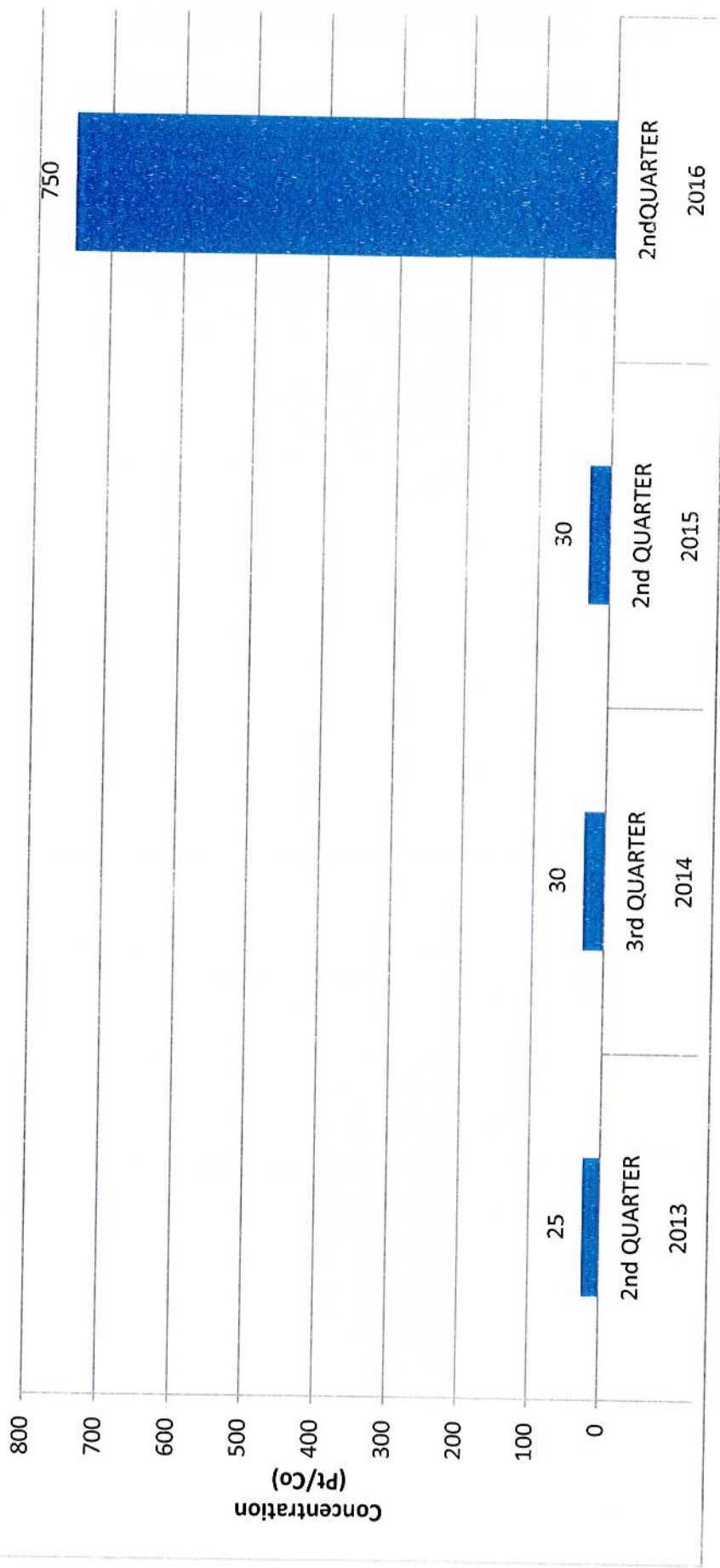


# New Windsor Landfill Quarterly Monitoring Reports MW 10D Iron

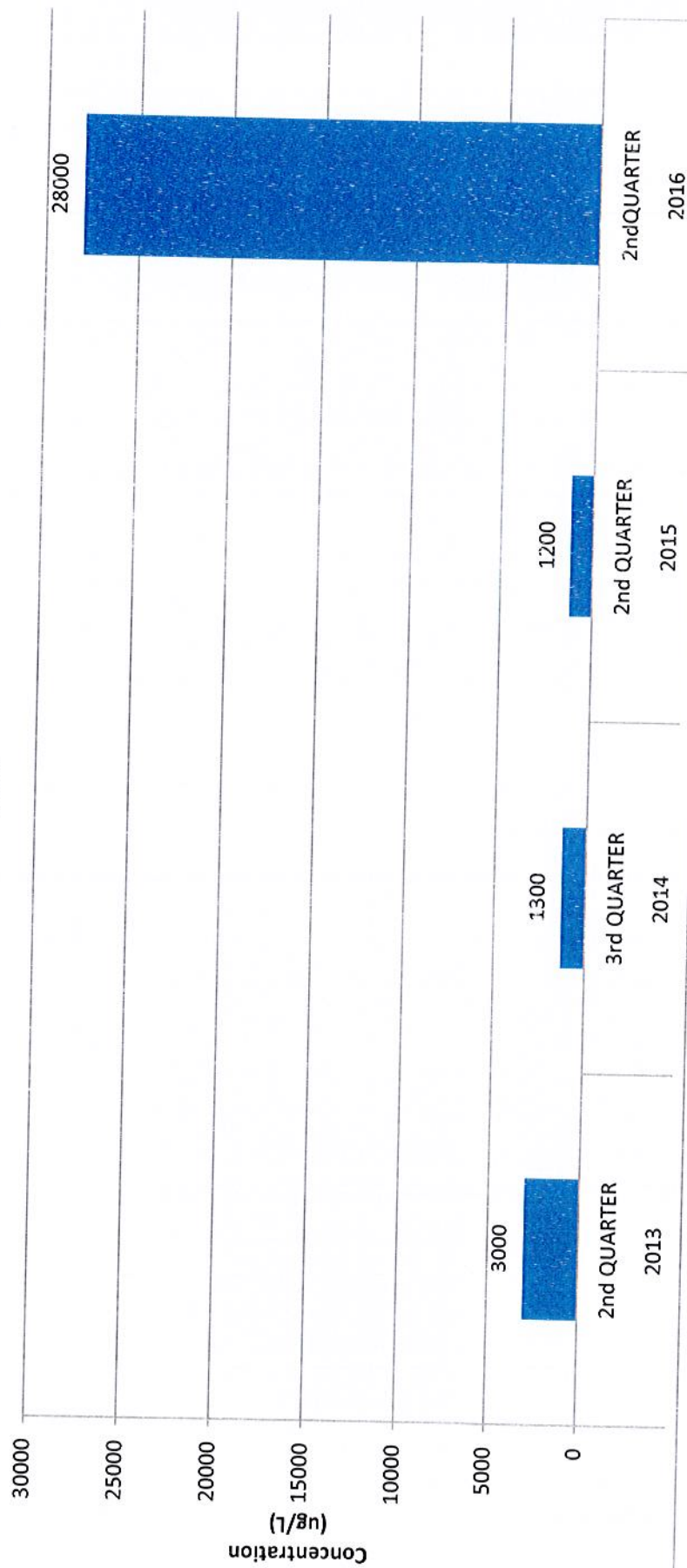




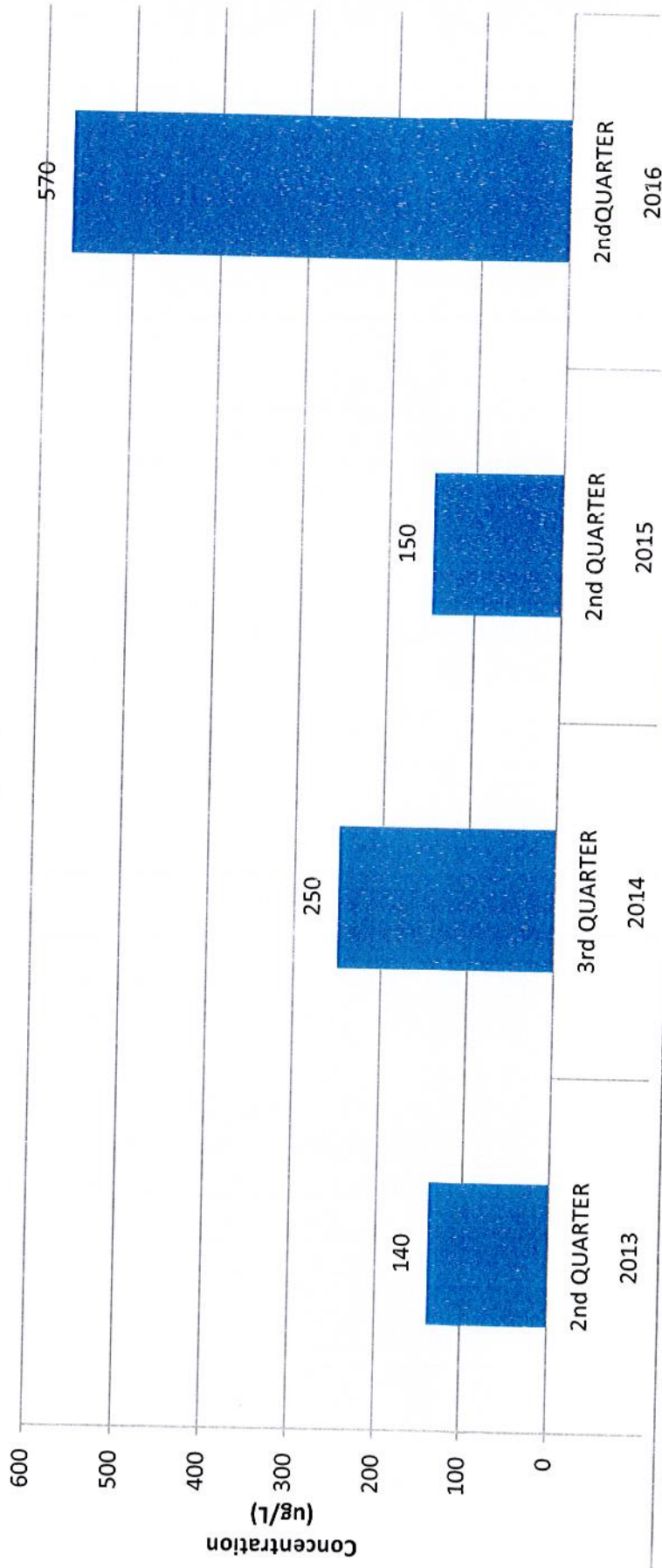
# New Windsor Landfill Quarterly Monitoring Reports MW 10S Color



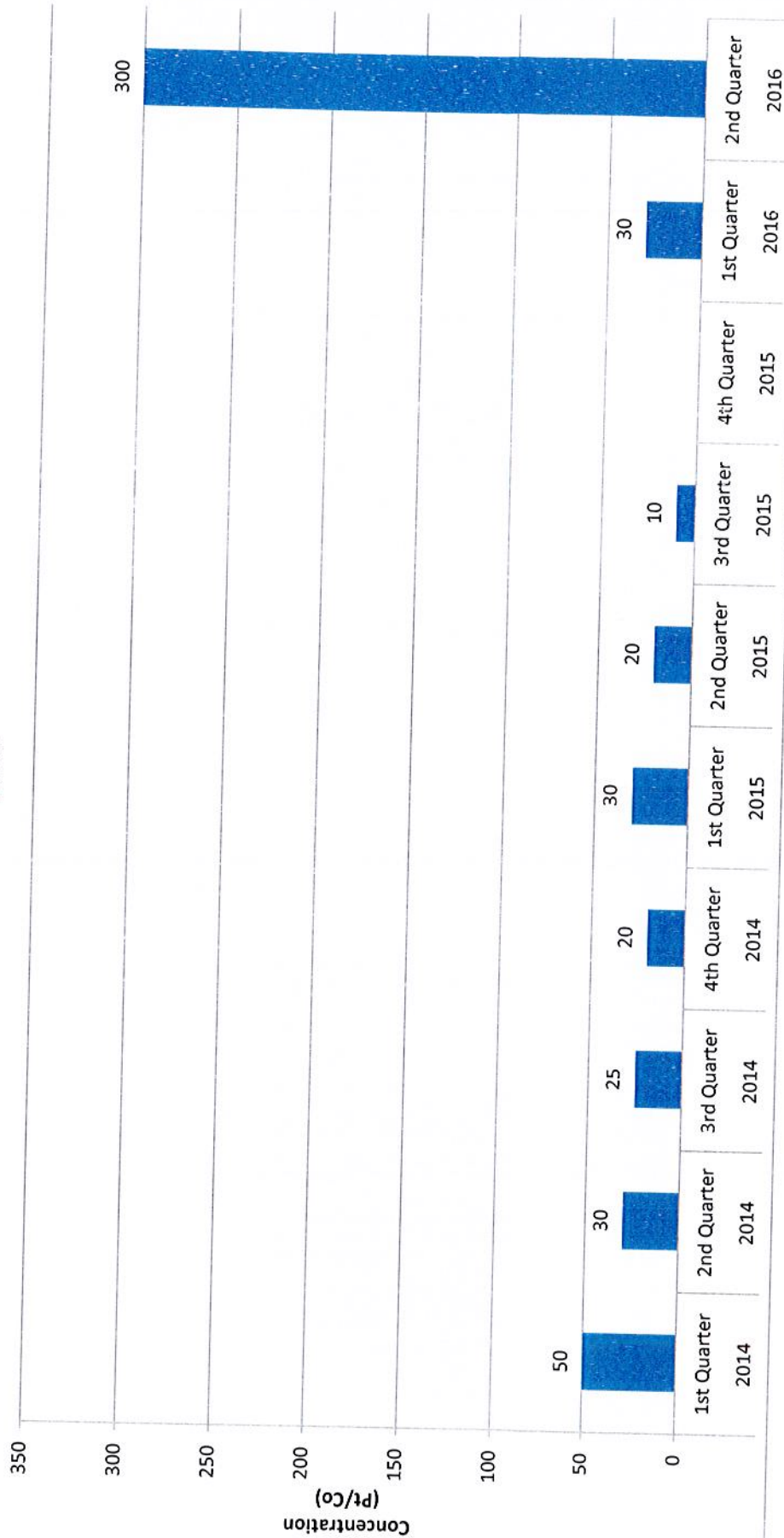
**New Windsor Landfill Quarterly Monitoring Reports  
MW 10S  
Iron**



**New Windsor Landfill Quarterly Monitoring Reports  
MW 10S  
Manganese**

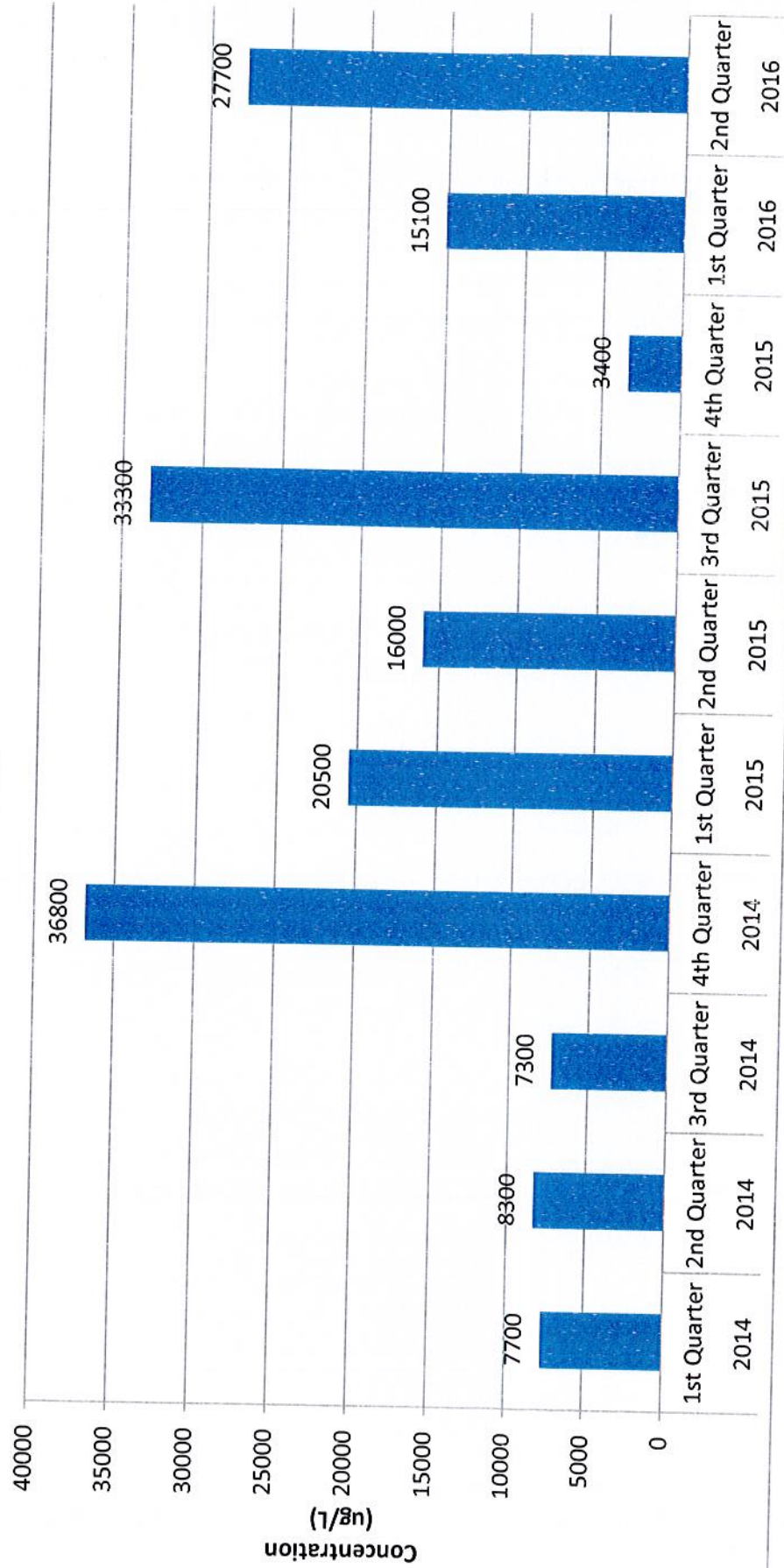


**New Windsor Landfill Quarterly Monitoring Reports  
MW 11S  
Color**

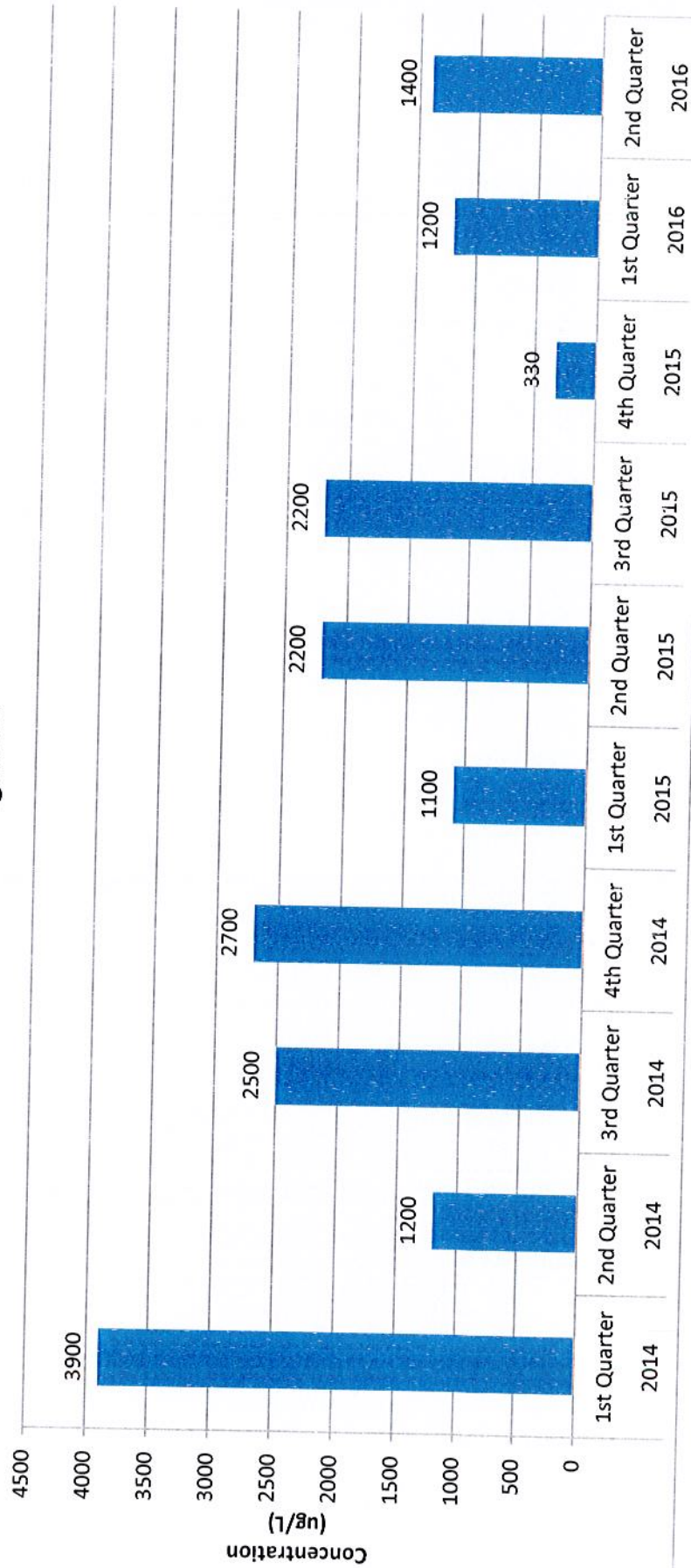




**New Windsor Landfill Quarterly Monitoring Reports  
MW 11S  
Iron**

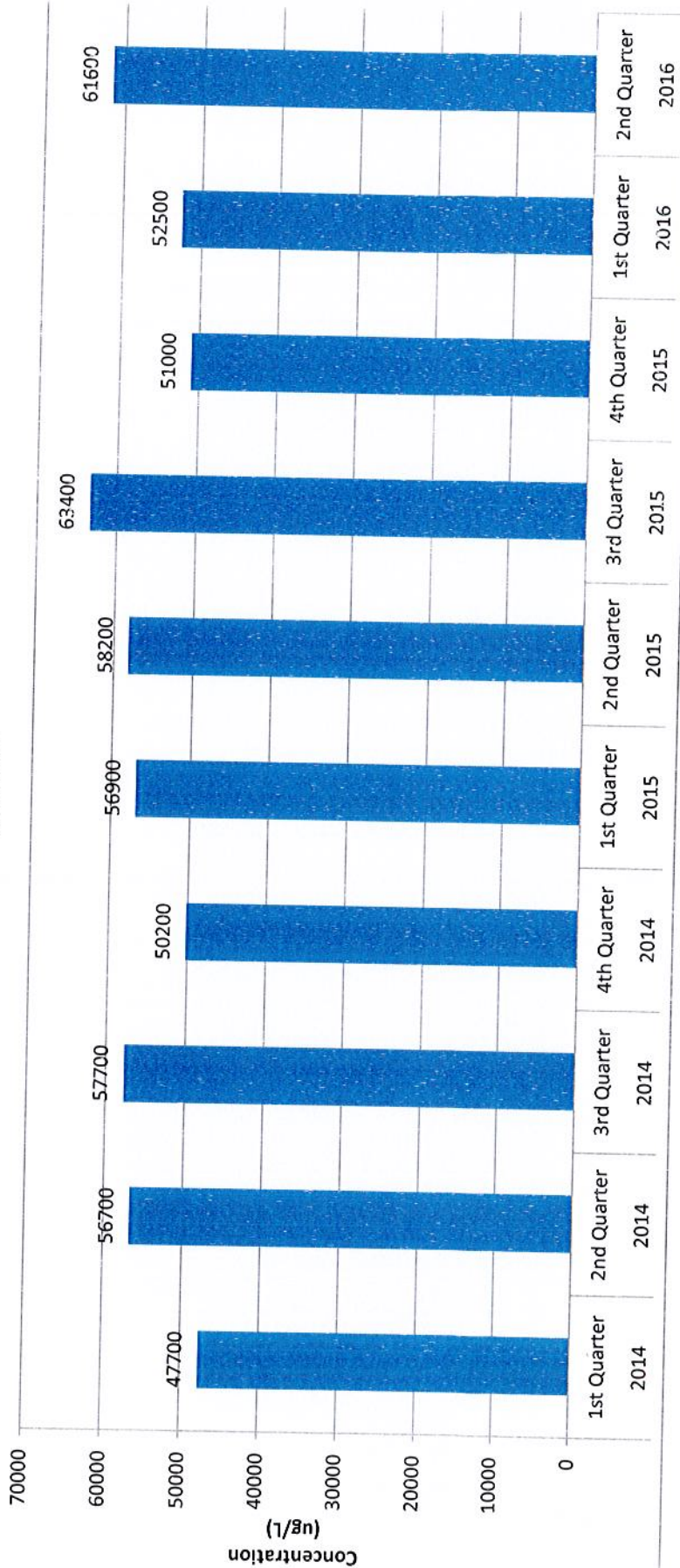


**New Windsor Landfill Quarterly Monitoring Reports  
MW 11S  
Manganese**

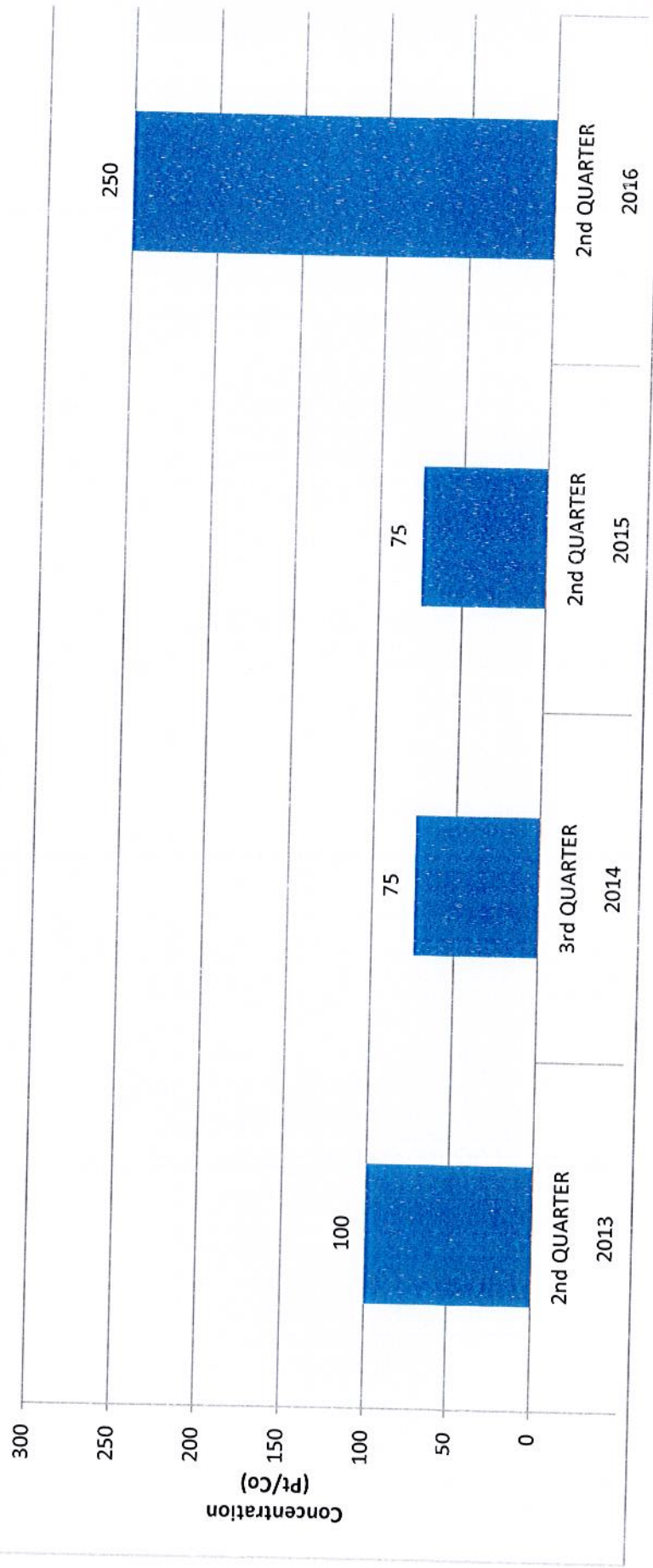




**New Windsor Landfill Quarterly Monitoring Reports  
MW 11S  
Sodium**



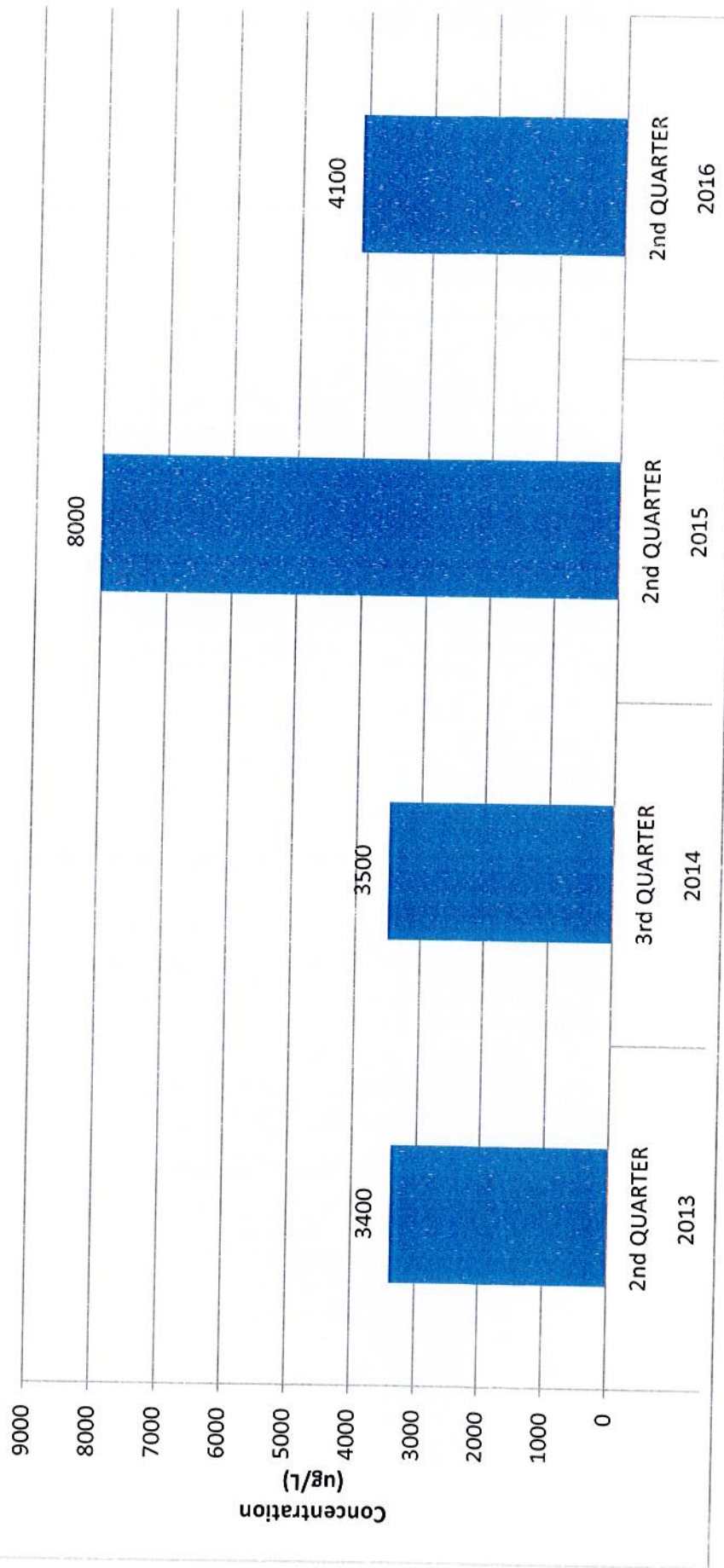
**New Windsor Landfill Quarterly Monitoring Reports  
Surface Water 1  
Color**



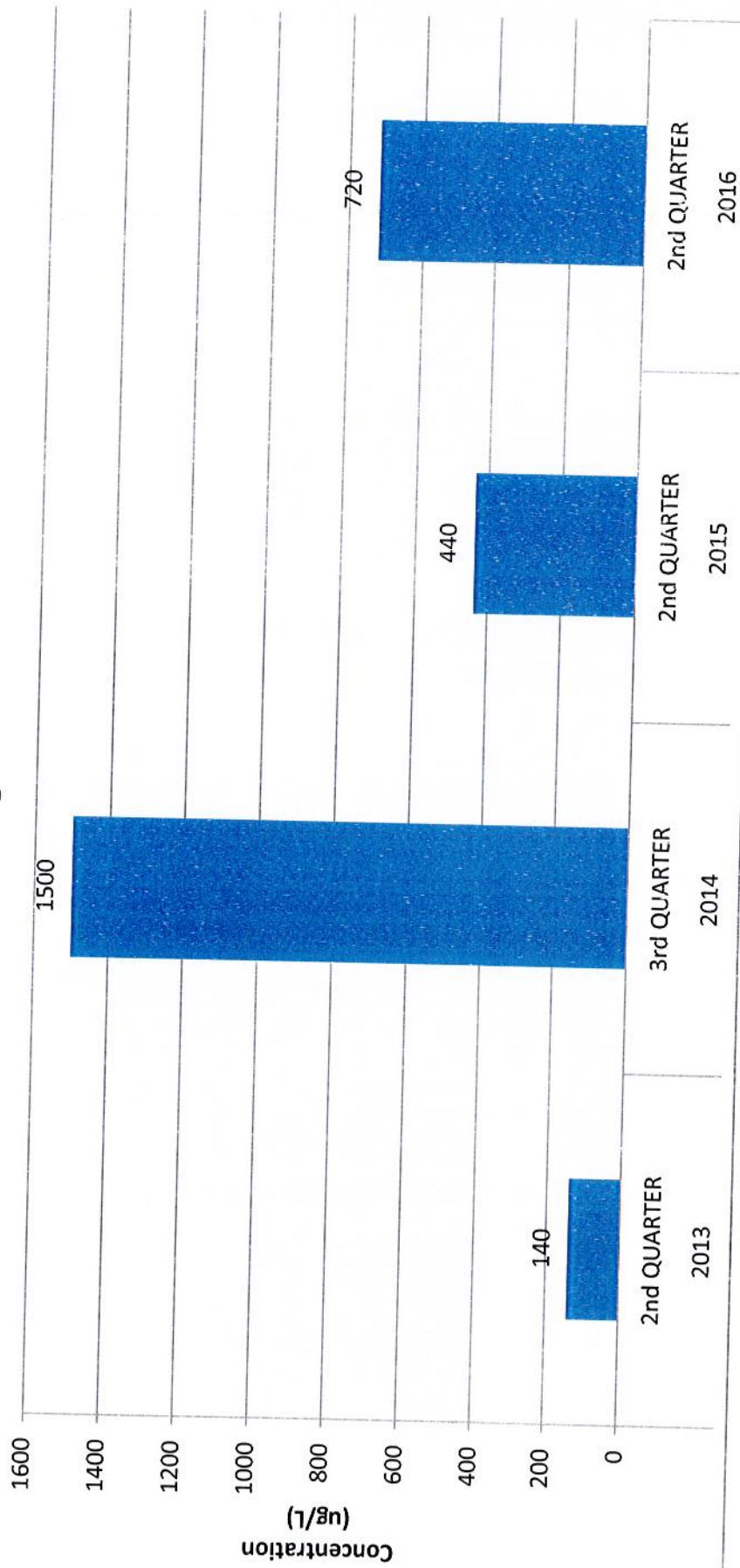
# New Windsor Landfill Quarterly Monitoring Reports

## Surface Water 1

### Iron

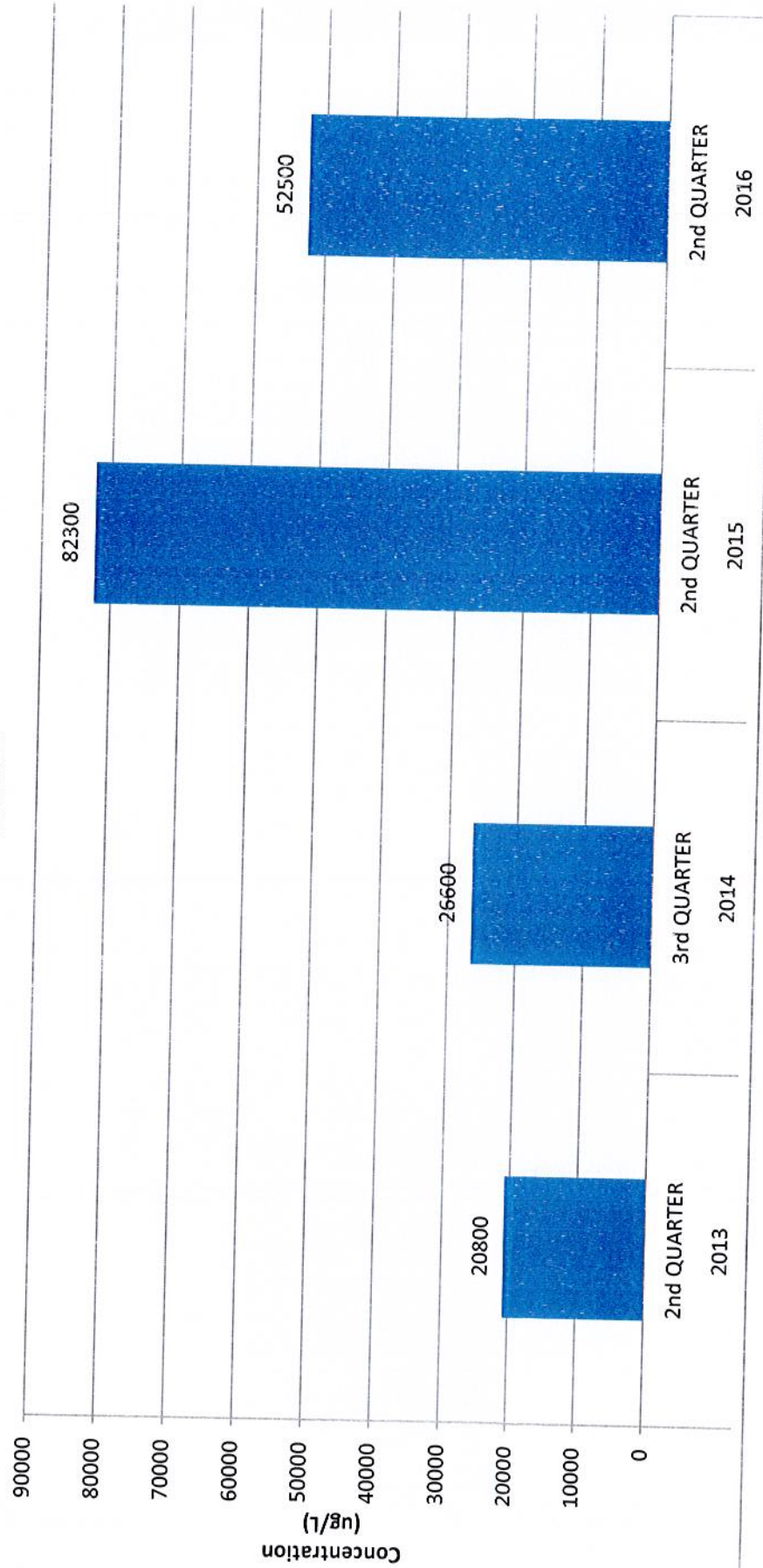


**New Windsor Landfill Quarterly Monitoring Reports**  
**Surface Water 1**  
**Manganese**





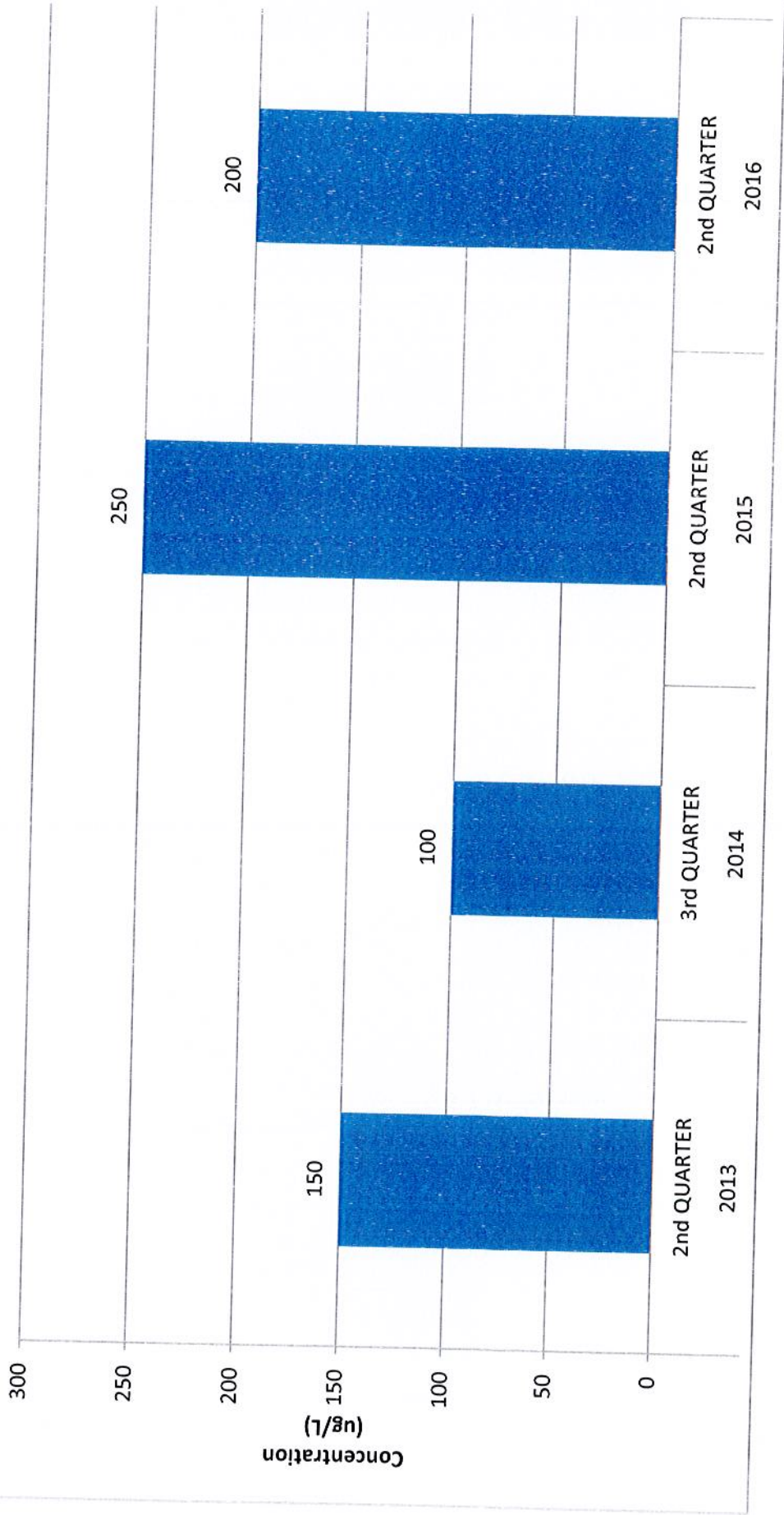
**New Windsor Landfill Quarterly Monitoring Reports  
Surface Water 1  
Sodium**



# New Windsor Landfill Quarterly Monitoring Reports

## Surface Water 2

### Color

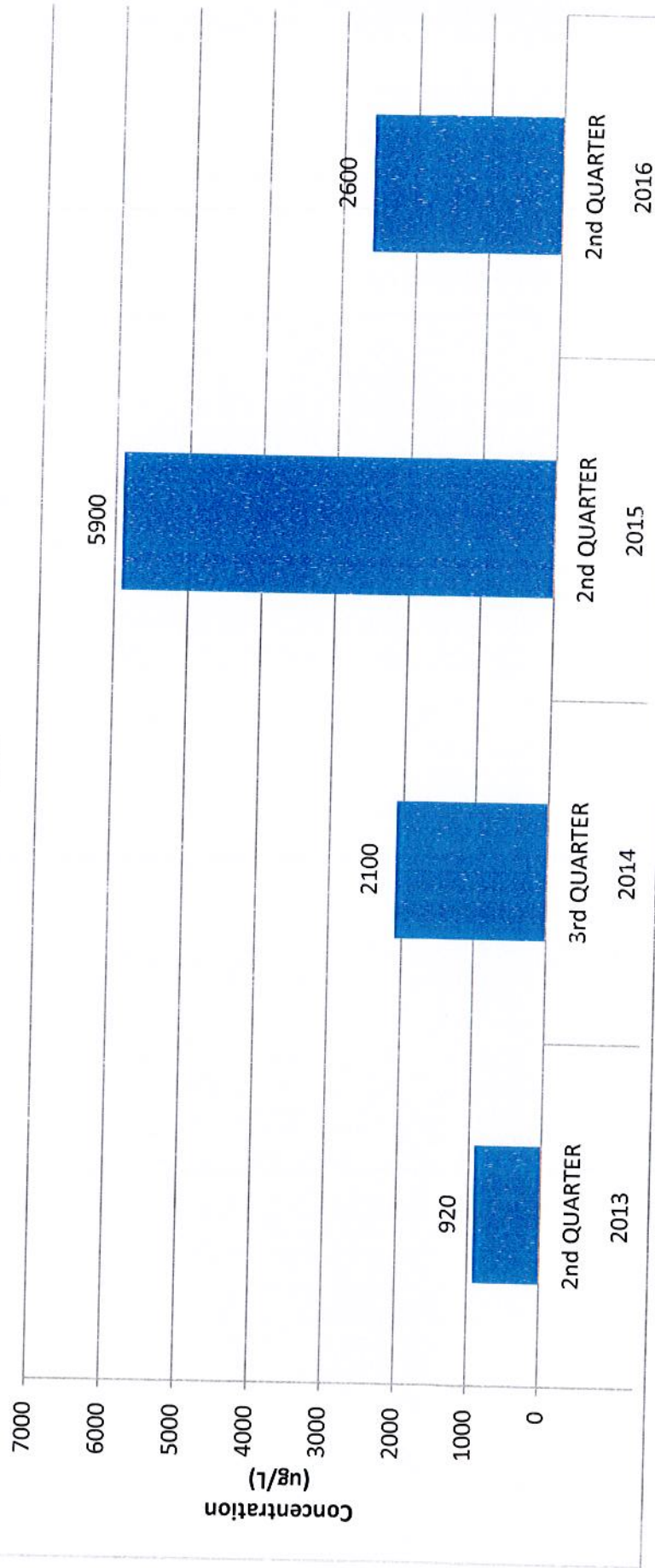




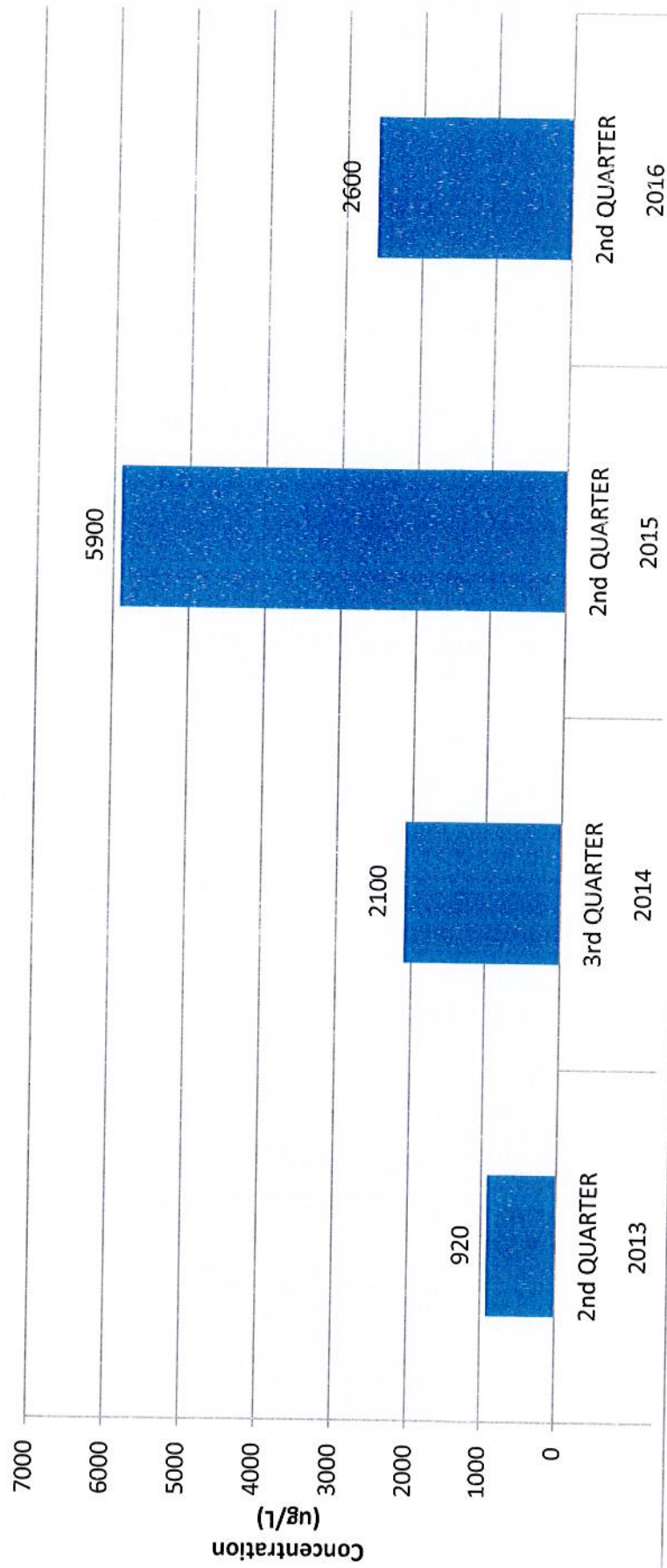
# New Windsor Landfill Quarterly Monitoring Reports

## Surface Water 2

### Iron



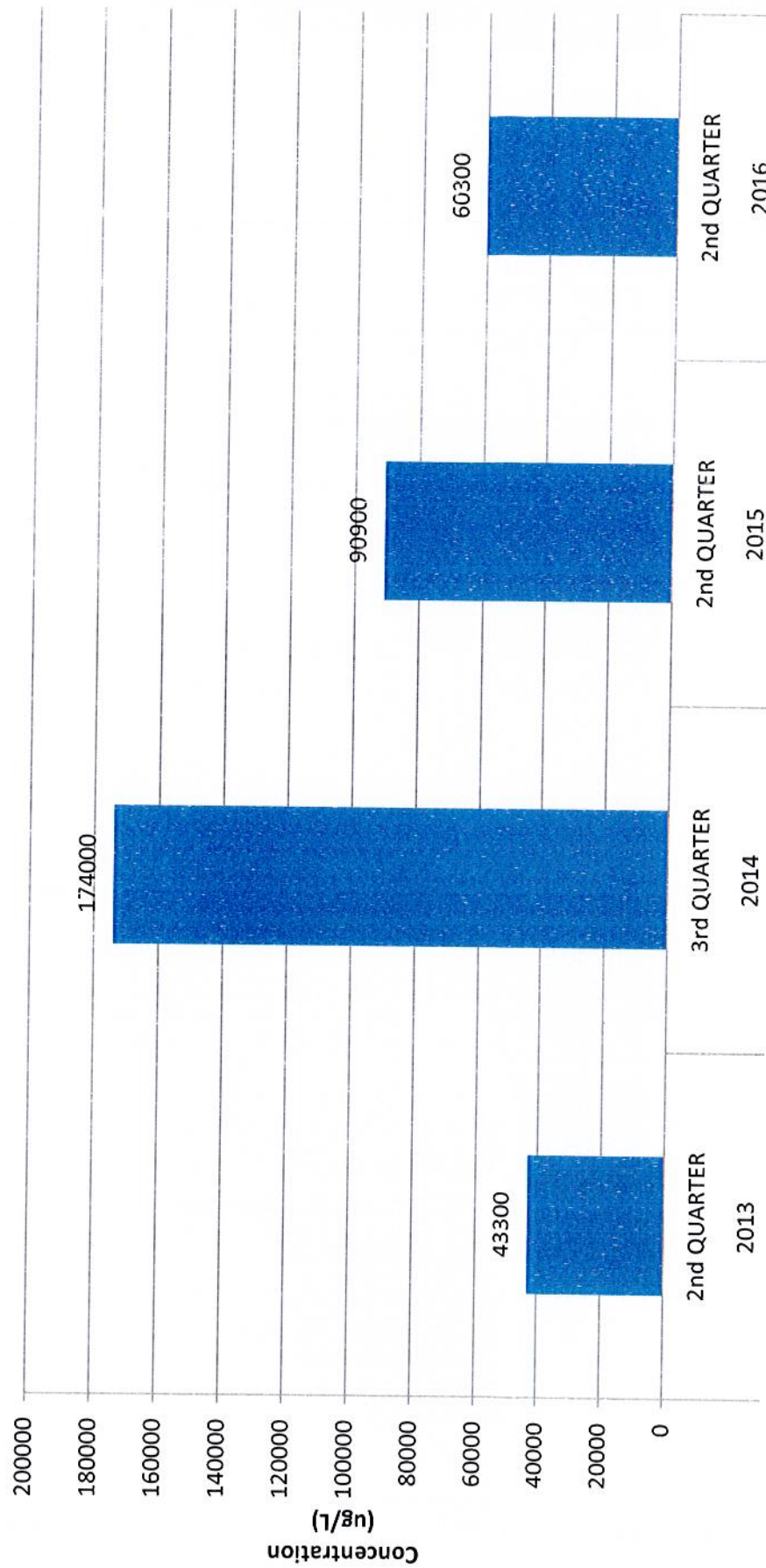
**New Windsor Landfill Quarterly Monitoring Reports  
Surface Water 2  
Manganese**



# New Windsor Landfill Quarterly Monitoring Reports

## Surface Water 2

### Sodium



# **ATTACHMENT 5**





Main Office  
 33 Airport Center Drive  
 Suite 202  
 New Windsor, New York 12553

**McGOEY, HAUSER and EDSALL  
 CONSULTING ENGINEERS D.P.C.**

(845) 567-3100  
 fax: (845) 567-3232  
 e-mail: mheny@mhepc.com

MARK J. EDSALL, P.E., P.P. (NY, NJ & PA)  
 MICHAEL W. WEEKS, P.E. (NY, NJ & PA)  
 MICHAEL J. LAMOREAUX, P.E. (NY, NJ, PA, VT & VA)  
 MATTHEW J. SICKLER, P.E. (NY & PA)  
 PATRICK J. HINES

Principal Emeritus:  
 RICHARD D. McGOEY, P.E. (NY & PA)  
 WILLIAM J. HAUSER, P.E. (NY, NJ & PA)

Sample Date: 26 May 2016  
 Report Date: 14 July 2016

**Monitoring Report:** sample type is grab, frequency is quarterly

<u>Parameter</u>	<u>Limit</u>	<u>Sample</u>	<u>Parameter</u>	<u>Limit</u>	<u>Sample</u>
Arsenic	0.02 mg/l	ND	Silver	0.1 mg/l	ND
BOD	Report	25	Selenium	0.2 mg/l	ND
Cadmium	0.02 mg/l	ND	Zinc	1.2 mg/l	ND
Chromium, Hex	0.2 mg/l	ND	Barium	4.0 mg/l	0.50
Chromium, total	2.0 mg/l	ND	Phenol	4.0 mg/l	0.014
Copper	0.8 mg/l	ND	Sulfide	6.0 mg/l	ND
Cyanide, total	0.2 mg/l	0.010	Manganese	4.0 mg/l	1.2
Lead	0.2 mg/l	ND	Gold	0.2 mg/l	ND
Mercury	0.1 mg/l	ND	pH	5.0-9.5 s.u.	6.50
Nickel	2.0 mg/l	ND	TSS	250 mg/l	83
Ignitability	>140°F	>150°F	Chlorine, avail.	50.0 mg/l	ND

**Certification Statement**

“I certify under penalty of law that this document and all attachments were prepared under my direction or supervision in accordance with a system designed to assure that qualified personnel properly gather and evaluate the information submitted. Based on my inquiry of the person or persons who manage the system, or those persons directly responsible for gathering the information, the information submitted is, to the best of my knowledge and belief, true, accurate, and complete. I am aware that there are significant penalties for submitting false information, including the possibility of fine and imprisonment for knowing violations.”

Respectfully submitted,

\_\_\_\_\_  
 Patrick J. Hines  
 Principal

MAN\WLANDFILL\monthly affirmation\23sk.doc







Main Office  
 33 Airport Center Drive  
 Suite 202  
 New Windsor, New York 12553

**McGOEY, HAUSER and EDSALL  
 CONSULTING ENGINEERS D.P.C.**

(845) 567-3100  
 fax: (845) 567-3232  
 e-mail: mheny@mhepc.com

MARK J. EDSALL, P.E., P.P. (NY, NJ & PA)  
 MICHAEL W. WEEKS, P.E. (NY, NJ & PA)  
 MICHAEL J. LAMOREAUX, P.E. (NY, NJ, PA, VT & VA)  
 MATTHEW J. SICKLER, P.E. (NY & PA)  
 PATRICK J. HINES

Principal Emeritus:  
 RICHARD D. McGOEY, P.E. (NY & PA)  
 WILLIAM J. HAUSER, P.E. (NY, NJ & PA)

Sample Date: 29 February 2016  
 Report Date: 29 March 2016

**Monitoring Report:** sample type is grab, frequency is quarterly

<u>Parameter</u>	<u>Limit</u>	<u>Sample</u>	<u>Parameter</u>	<u>Limit</u>	<u>Sample</u>
Arsenic	0.02 mg/l	ND	Silver	0.1 mg/l	ND
BOD	Report	24	Selenium	0.2 mg/l	ND
Cadmium	0.02 mg/l	ND	Zinc	1.2 mg/l	ND
Chromium, Hex	0.2 mg/l	ND	Barium	4.0 mg/l	0.39
Chromium, total	2.0 mg/l	ND	Phenol	4.0 mg/l	0.014
Copper	0.8 mg/l	ND	Sulfide	6.0 mg/l	ND
Cyanide, total	0.2 mg/l	0.010	Manganese	4.0 mg/l	1.0
Lead	0.2 mg/l	.006	Gold	0.2 mg/l	ND
Mercury	0.1 mg/l	ND	pH	5.0-9.5 s.u.	6.50
Nickel	2.0 mg/l	ND	TSS	250 mg/l	100
Ignitability	>140°F	>150°F	Chlorine, avail.	50.0 mg/l	ND

**Certification Statement**

“I certify under penalty of law that this document and all attachments were prepared under my direction or supervision in accordance with a system designed to assure that qualified personnel properly gather and evaluate the information submitted. Based on my inquiry of the person or persons who manage the system, or those persons directly responsible for gathering the information, the information submitted is, to the best of my knowledge and belief, true, accurate, and complete. I am aware that there are significant penalties for submitting false information, including the possibility of fine and imprisonment for knowing violations.”

Respectfully submitted,

\_\_\_\_\_  
 Patrick J. Hines  
 Principal

M:\NWLANDFILL\monthly affirmation\23sk.doc





Main Office  
 33 Airport Center Drive  
 Suite 202  
 New Windsor, New York 12553

**McGOEY, HAUSER and EDSALL  
 CONSULTING ENGINEERS D.P.C.**

(845) 567-3100  
 fax: (845) 567-3232  
 e-mail: mheny@mhepc.com

MARK J. EDSALL, P.E., P.P. (NY, NJ & PA)  
 MICHAEL W. WEEKS, P.E. (NY, NJ & PA)  
 MICHAEL J. LAMOREAUX, P.E. (NY, NJ, PA, VT & VA)  
 MATTHEW J. SICKLER, P.E. (NY & PA)  
 PATRICK J. HINES

Principal Emeritus:  
 RICHARD D. McGOEY, P.E. (NY & PA)  
 WILLIAM J. HAUSER, P.E. (NY, NJ & PA)

Sample Date: 25 August 2015  
 Report Date: 14 October 2015

**Monitoring Report:** sample type is grab, frequency is quarterly

<u>Parameter</u>	<u>Limit</u>	<u>Sample</u>	<u>Parameter</u>	<u>Limit</u>	<u>Sample</u>
Arsenic	0.02 mg/l	ND	Silver	0.1 mg/l	ND
BOD	Report	9.4	Selenium	0.2 mg/l	ND
Cadmium	0.02 mg/l	ND	Zinc	1.2 mg/l	ND
Chromium, Hex	0.2 mg/l	ND	Barium	4.0 mg/l	0.62
Chromium, total	2.0 mg/l	ND	Phenol	4.0 mg/l	0.014
Copper	0.8 mg/l	ND	Sulfide	6.0 mg/l	ND
Cyanide, total	0.2 mg/l	0.010	Manganese	4.0 mg/l	1.7
Lead	0.2 mg/l	ND	Gold	0.2 mg/l	ND
Mercury	0.1 mg/l	ND	pH	5.0-9.5 s.u.	6.57
Nickel	2.0 mg/l	ND	TSS	250 mg/l	120
Ignitability	>140°F	>150°F	Chlorine, avail.	50.0 mg/l	ND

**Certification Statement**

“I certify under penalty of law that this document and all attachments were prepared under my direction or supervision in accordance with a system designed to assure that qualified personnel properly gather and evaluate the information submitted. Based on my inquiry of the person or persons who manage the system, or those persons directly responsible for gathering the information, the information submitted is, to the best of my knowledge and belief, true, accurate, and complete. I am aware that there are significant penalties for submitting false information, including the possibility of fine and imprisonment for knowing violations.”

Respectfully submitted,

\_\_\_\_\_  
 Patrick J. Hines  
 Principal

MANWLANDFILL\monthly affirmation\23sk.doc





Main Office  
 33 Airport Center Drive  
 Suite 202  
 New Windsor, New York 12553

**McGOEY, HAUSER and EDSALL  
 CONSULTING ENGINEERS D.P.C.**

(845) 567-3100  
 fax: (845) 567-3232  
 e-mail: mheny@mhepc.com

MARK J. EDSALL, P.E., P.P. (NY, NJ & PA)  
 MICHAEL W. WEEKS, P.E. (NY, NJ & PA)  
 MICHAEL J. LAMOREAUX, P.E. (NY, NJ, PA, VT & VA)  
 MATTHEW J. SICKLER, P.E. (NY & PA)  
 PATRICK J. HINES

Principal Emeritus:  
 RICHARD D. McGOEY, P.E. (NY & PA)  
 WILLIAM J. HAUSER, P.E. (NY, NJ & PA)

Sample Date: 18 June 2015  
 Report Date: 31 July 2015

**Monitoring Report:** sample type is grab, frequency is quarterly

Parameter	Limit	Sample	Parameter	Limit	Sample
Arsenic	0.02 mg/l	ND	Silver	0.1 mg/l	ND
BOD	Report	28	Selenium	0.2 mg/l	ND
Cadmium	0.02 mg/l	ND	Zinc	1.2 mg/l	ND
Chromium, Hex	0.2 mg/l	ND	Barium	4.0 mg/l	0.52
Chromium, total	2.0 mg/l	ND	Phenol	4.0 mg/l	ND
Copper	0.8 mg/l	ND	Sulfide	6.0 mg/l	ND
Cyanide, total	0.2 mg/l	0.010	Manganese	4.0 mg/l	1.4
Lead	0.2 mg/l	0,005	Gold	0.2 mg/l	ND
Mercury	0.1 mg/l	ND	pH	5.0-9.5 s.u.	6.43
Nickel	2.0 mg/l	ND	TSS	250 mg/l	80
Ignitability	>140°F	>150°F	Chlorine, avail.	50.0 mg/l	ND

**Certification Statement**

“I certify under penalty of law that this document and all attachments were prepared under my direction or supervision in accordance with a system designed to assure that qualified personnel properly gather and evaluate the information submitted. Based on my inquiry of the person or persons who manage the system, or those persons directly responsible for gathering the information, the information submitted is, to the best of my knowledge and belief, true, accurate, and complete. I am aware that there are significant penalties for submitting false information, including the possibility of fine and imprisonment for knowing violations.”

Respectfully submitted,

\_\_\_\_\_  
 Patrick J. Hines  
 Principal

MANWLANDFILL\monthly affirmation\23sk.doc







Main Office  
 33 Airport Center Drive  
 Suite 202  
 New Windsor, New York 12553

**McGOEY, HAUSER and EDSALL  
 CONSULTING ENGINEERS D.P.C.**

(845) 567-3100  
 fax: (845) 567-3232  
 e-mail: mheny@mhepc.com

MARK J. EDSALL, P.E., P.P. (NY, NJ & PA)  
 MICHAEL W. WEEKS, P.E. (NY, NJ & PA)  
 MICHAEL J. LAMOREAUX, P.E. (NY, NJ, PA, VT & VA)  
 MATTHEW J. SICKLER, P.E. (NY & PA)  
 PATRICK J. HINES

Principal Emeritus:  
 RICHARD D. McGOEY, P.E. (NY & PA)  
 WILLIAM J. HAUSER, P.E. (NY, NJ & PA)

Sample Date: 26 March 2015  
 Report Date: 6 April 2015

**Monitoring Report:** sample type is grab, frequency is quarterly

<u>Parameter</u>	<u>Limit</u>	<u>Sample</u>	<u>Parameter</u>	<u>Limit</u>	<u>Sample</u>
Arsenic	0.02 mg/l	ND	Silver	0.1 mg/l	ND
BOD	Report	8.0	Selenium	0.2 mg/l	ND
Cadmium	0.02 mg/l	ND	Zinc	1.2 mg/l	ND
Chromium, Hex	0.2 mg/l	ND	Barium	4.0 mg/l	0.20
Chromium, total	2.0 mg/l	ND	Phenol	4.0 mg/l	ND
Copper	0.8 mg/l	ND	Sulfide	6.0 mg/l	ND
Cyanide, total	0.2 mg/l	0.014	Manganese	4.0 mg/l	1.0
Lead	0.2 mg/l	ND	Gold	0.2 mg/l	ND
Mercury	0.1 mg/l	ND	pH	5.0-9.5 s.u.	7.16
Nickel	2.0 mg/l	ND	TSS	250 mg/l	8.6
Ignitability	>140°F	>150°F	Chlorine, avail.	50.0 mg/l	ND

**Certification Statement**

“I certify under penalty of law that this document and all attachments were prepared under my direction or supervision in accordance with a system designed to assure that qualified personnel properly gather and evaluate the information submitted. Based on my inquiry of the person or persons who manage the system, or those persons directly responsible for gathering the information, the information submitted is, to the best of my knowledge and belief, true, accurate, and complete. I am aware that there are significant penalties for submitting false information, including the possibility of fine and imprisonment for knowing violations.”

Respectfully submitted,

\_\_\_\_\_  
 Patrick J. Hines  
 Principal

MANWLANDFIL\monthly affirmation\23sk.doc





**McGOEY, HAUSER and EDSALL  
CONSULTING ENGINEERS P.C.**

RICHARD D. MCGOEY, P.E. (NY & PA)  
WILLIAM J. HAUSER, P.E. (NY & NJ)  
MARK J. EDSALL, P.E. (NY, NJ & PA)  
JAMES M. FARR, P.E. (NY & PA)

MAIN OFFICE  
33 Airport Center Drive  
Suite 202  
New Windsor, New York 12553

(845) 567-3100  
fax: (845) 567-3232  
e-mail: mheny@mhepc.com

Sample Date: 8 Dec. 2014  
Report Date: 29Jan. 2015

**Monitoring Report:** sample type is grab, frequency is quarterly

<u>Parameter</u>	<u>Limit</u>	<u>Sample</u>	<u>Parameter</u>	<u>Limit</u>	<u>Sample</u>
Arsenic	0.02 mg/l	ND	Silver	0.1 mg/l	ND
BOD	Report	12	Selenium	0.2 mg/l	ND
Cadmium	0.02 mg/l	ND	Zinc	1.2 mg/l	ND
Chromium, Hex	0.2 mg/l	ND	Barium	4.0 mg/l	0.37
Chromium, total	2.0 mg/l	ND	Phenol	4.0 mg/l	ND
Copper	0.8 mg/l	ND	Sulfide	6.0 mg/l	ND
Cyanide, total	0.2 mg/l	ND	Manganese	4.0 mg/l	1.1
Lead	0.2 mg/l	ND	Gold	0.2 mg/l	ND
Mercury	0.1 mg/l	ND	pH	5.0-9.5 s.u.	7.04
Nickel	2.0 mg/l	ND	TSS	250 mg/l	39
Ignitability	>140°F	>150°F	Chlorine, avail.	50.0 mg/l	ND

**Certification Statement**

“I certify under penalty of law that this document and all attachments were prepared under my direction or supervision in accordance with a system designed to assure that qualified personnel properly gather and evaluate the information submitted. Based on my inquiry of the person or persons who manage the system, or those persons directly responsible for gathering the information, the information submitted is, to the best of my knowledge and belief, true, accurate, and complete. I am aware that there are significant penalties for submitting false information, including the possibility of fine and imprisonment for knowing violations.”

Respectfully submitted,

\_\_\_\_\_  
Patrick J. Hines  
Associate

M:\NWL\ANDFILL\monthly affirmation\23sk.doc

REGIONAL OFFICES

- 111 Wheatfield Drive • Milford, Pennsylvania 18337 • 570-296-2765 •
- 540 Broadway • Monticello, New York 12701 • 845-794-3399 •





**McGOEY, HAUSER and EDSALL**  
CONSULTING ENGINEERS P.C.

RICHARD D. MCGOEY, P.E. (NY & PA)  
WILLIAM J. HAUSER, P.E. (NY & NJ)  
MARK J. EDSALL, P.E. (NY, NJ & PA)  
JAMES M. FARR, P.E. (NY & PA)

MAIN OFFICE  
33 Airport Center Drive  
Suite 202  
New Windsor, New York 12553

(845) 567-3100  
fax: (845) 567-3232  
e-mail: mheny@mhepc.com

Sample Date: 28 Aug. 2014  
Report Date: 7 Oct. 2014

**Monitoring Report:** sample type is grab, frequency is quarterly

<u>Parameter</u>	<u>Limit</u>	<u>Sample</u>	<u>Parameter</u>	<u>Limit</u>	<u>Sample</u>
Arsenic	0.02 mg/l	ND	Silver	0.1 mg/l	ND
BOD	Report	12	Selenium	0.2 mg/l	ND
Cadmium	0.02 mg/l	ND	Zinc	1.2 mg/l	ND
Chromium, Hex	0.2 mg/l	ND	Barium	4.0 mg/l	0.60
Chromium, total	2.0 mg/l	ND	Phenol	4.0 mg/l	ND
Copper	0.8 mg/l	ND	Sulfide	6.0 mg/l	ND
Cyanide, total	0.2 mg/l	ND	Manganese	4.0 mg/l	1.5
Lead	0.2 mg/l	ND	Gold	0.2 mg/l	ND
Mercury	0.1 mg/l	ND	pH	5.0-9.5 s.u.	6.6
Nickel	2.0 mg/l	ND	TSS	250 mg/l	20
Ignitability	>140°F	>150°F	Chlorine, avail.	50.0 mg/l	ND

**Certification Statement**

“I certify under penalty of law that this document and all attachments were prepared under my direction or supervision in accordance with a system designed to assure that qualified personnel properly gather and evaluate the information submitted. Based on my inquiry of the person or persons who manage the system, or those persons directly responsible for gathering the information, the information submitted is, to the best of my knowledge and belief, true, accurate, and complete. I am aware that there are significant penalties for submitting false information, including the possibility of fine and imprisonment for knowing violations.”

Respectfully submitted,

\_\_\_\_\_  
Patrick J. Hines  
Associate

M:\NWL\LANDFILE\monthly affirmation\23sk.doc

REGIONAL OFFICES

- 111 Wheatfield Drive • Milford, Pennsylvania 18337 • 570-296-2765 •
- 540 Broadway • Monticello, New York 12701 • 845-794-3399 •







**McGOEY, HAUSER and EDSALL**  
CONSULTING ENGINEERS P.C.

RICHARD D. McGOEY, P.E. (NY & PA)  
WILLIAM J. HAUSER, P.E. (NY & NJ)  
MARK J. EDSALL, P.E. (NY, NJ & PA)  
JAMES M. FARR, P.E. (NY & PA)

MAIN OFFICE  
33 Airport Center Drive  
Suite 202  
New Windsor, New York 12553

(845) 567-3100  
fax: (845) 567-3232  
e-mail: mheny@mhepc.com

Sample Date: 11 June 2014 Chromium resample 17 June 2014  
Report Date: 14 July 2014

**Monitoring Report:** sample type is grab, frequency is quarterly

<u>Parameter</u>	<u>Limit</u>	<u>Sample</u>	<u>Parameter</u>	<u>Limit</u>	<u>Sample</u>
Arsenic	0.02 mg/l	ND	Silver	0.1 mg/l	ND
BOD	Report	22	Selenium	0.2 mg/l	ND
Cadmium	0.02 mg/l	ND	Zinc	1.2 mg/l	ND
Chromium, Hex	0.2 mg/l	ND	Barium	4.0 mg/l	0.51
Chromium, total	2.0 mg/l	ND	Phenol	4.0 mg/l	ND
Copper	0.8 mg/l	ND	Sulfide	6.0 mg/l	ND
Cyanide, total	0.2 mg/l	ND	Manganese	4.0 mg/l	1.5
Lead	0.2 mg/l	0.08	Gold	0.2 mg/l	ND
Mercury	0.1 mg/l	ND	pH	5.0-9.5 s.u.	6.05
Nickel	2.0 mg/l	ND	TSS	250 mg/l	47
Ignitability	>140°F	>150°F	Chlorine, avail.	50.0 mg/l	ND

**Certification Statement**

"I certify under penalty of law that this document and all attachments were prepared under my direction or supervision in accordance with a system designed to assure that qualified personnel properly gather and evaluate the information submitted. Based on my inquiry of the person or persons who manage the system, or those persons directly responsible for gathering the information, the information submitted is, to the best of my knowledge and belief, true, accurate, and complete. I am aware that there are significant penalties for submitting false information, including the possibility of fine and imprisonment for knowing violations."

Respectfully submitted,

\_\_\_\_\_  
Patrick J. Hines  
Associate

MANWLANDFIL\monthly affirmation\23sk.doc

REGIONAL OFFICES

- 111 Wheatfield Drive • Milford, Pennsylvania 18337 • 570-296-2765 •
- 540 Broadway • Monticello, New York 12701 • 845-794-3399 •





**McGOEY, HAUSER and EDSALL**  
CONSULTING ENGINEERS P.C.

RICHARD D. MCGOEY, P.E. (NY & PA)  
WILLIAM J. HAUSER, P.E. (NY & NJ)  
MARK J. EDSALL, P.E. (NY, NJ & PA)  
JAMES M. FARR, P.E. (NY & PA)

MAIN OFFICE  
33 Airport Center Drive  
Suite 202  
New Windsor, New York 12553

(845) 567-3100  
fax: (845) 567-3232  
e-mail: mheny@mhepc.com

Sample Date: 17 May 2013  
Report Date: 17 June 2013

**Monitoring Report:** sample type is grab, frequency is quarterly

Parameter	Limit	Sample	Parameter	Limit	Sample
Arsenic	0.02 mg/l	ND	Silver	0.1 mg/l	ND
BOD	Report	54	Selenium	0.2 mg/l	ND
Cadmium	0.02 mg/l	ND	Zinc	1.2 mg/l	ND
Chromium, Hex	0.2 mg/l	ND	Barium	4.0 mg/l	0.50
Chromium, total	2.0 mg/l	ND	Phenol	4.0 mg/l	ND
Copper	0.8 mg/l	ND	Sulfide	6.0 mg/l	ND
Cyanide, total	0.2 mg/l	ND	Manganese	4.0 mg/l	1.6
Lead	0.2 mg/l	ND	Gold	0.2 mg/l	ND
Mercury	0.1 mg/l	ND	pH	5.0-9.5 s.u.	6.53
Nickel	2.0 mg/l	ND	TSS	250 mg/l	80
Ignitability	>140°F	>150°F	Chlorine, avail.	50.0 mg/l	ND

**Certification Statement**

"I certify under penalty of law that this document and all attachments were prepared under my direction or supervision in accordance with a system designed to assure that qualified personnel properly gather and evaluate the information submitted. Based on my inquiry of the person or persons who manage the system, or those persons directly responsible for gathering the information, the information submitted is, to the best of my knowledge and belief, true, accurate, and complete. I am aware that there are significant penalties for submitting false information, including the possibility of fine and imprisonment for knowing violations."

Respectfully submitted,

\_\_\_\_\_  
Patrick J. Hines  
Associate

M:\NWLANDFILL\monthly affirmation\23sk.doc

REGIONAL OFFICES

- 111 Wheatfield Drive • Milford, Pennsylvania 18337 • 570-296-2765 •
- 540 Broadway • Monticello, New York 12701 • 845-794-3399 •





**McGOEY, HAUSER and EDSALL**  
CONSULTING ENGINEERS P.C.

RICHARD D. McGOEY, P.E. (NY & PA)  
WILLIAM J. HAUSER, P.E. (NY & NJ)  
MARK J. EDSALL, P.E. (NY, NJ & PA)  
JAMES M. FARR, P.E. (NY & PA)

MAIN OFFICE  
33 Airport Center Drive  
Suite 202  
New Windsor, New York 12553

(845) 567-3100  
fax: (845) 567-3232  
e-mail: mheny@mhepc.com

Sample Date: 31 March, 2014  
Report Date: 28 April 2014

**Monitoring Report:** sample type is grab, frequency is quarterly

<u>Parameter</u>	<u>Limit</u>	<u>Sample</u>	<u>Parameter</u>	<u>Limit</u>	<u>Sample</u>
Arsenic	0.02 mg/l	ND	Silver	0.1 mg/l	ND
BOD	Report	13	Selenium	0.2 mg/l	ND
Cadmium	0.02 mg/l	ND	Zinc	1.2 mg/l	ND
Chromium, Hex	0.2 mg/l	ND	Barium	4.0 mg/l	0.39
Chromium, total	2.0 mg/l	ND	Phenol	4.0 mg/l	ND
Copper	0.8 mg/l	ND	Sulfide	6.0 mg/l	ND
Cyanide, total	0.2 mg/l	ND	Manganese	4.0 mg/l	1.1
Lead	0.2 mg/l	ND	Gold	0.2 mg/l	ND
Mercury	0.1 mg/l	ND	pH	5.0-9.5 s.u.	6.58
Nickel	2.0 mg/l	ND	TSS	250 mg/l	64
Ignitability	>140°F	>150°F	Chlorine, avail.	50.0 mg/l	ND

**Certification Statement**

“I certify under penalty of law that this document and all attachments were prepared under my direction or supervision in accordance with a system designed to assure that qualified personnel properly gather and evaluate the information submitted. Based on my inquiry of the person or persons who manage the system, or those persons directly responsible for gathering the information, the information submitted is, to the best of my knowledge and belief, true, accurate, and complete. I am aware that there are significant penalties for submitting false information, including the possibility of fine and imprisonment for knowing violations.”

Respectfully submitted,

\_\_\_\_\_  
Patrick J. Hines  
Associate

M:\NWLANDFILL\monthly affirmation\23sk.doc

REGIONAL OFFICES

- 111 Wheatfield Drive • Milford, Pennsylvania 18337 • 570-296-2765 •
- 540 Broadway • Monticello, New York 12701 • 845-794-3399 •







**MAIN OFFICE**  
 33 Airport Center Drive  
 Suite 202  
 New Windsor, New York 12553

(845) 567-3100  
 fax: (845) 567-3232  
 e-mail: mheny@mhepc.com

**McGOEY, HAUSER and EDSALL  
 CONSULTING ENGINEERS P.C.**

RICHARD D. MCGOEY, P.E. (NY & PA)  
 WILLIAM J. HAUSER, P.E. (NY & NJ)  
 MARK J. EDSALL, P.E. (NY, NJ & PA)  
 JAMES M. FARR, P.E. (NY & PA)

Sample Date: 9 Dec. 2013  
 Report Date: 9 Jan 2014

**Monitoring Report:** sample type is grab, frequency is quarterly

<u>Parameter</u>	<u>Limit</u>	<u>Sample</u>	<u>Parameter</u>	<u>Limit</u>	<u>Sample</u>
Arsenic	0.02 mg/l	ND	Silver	0.1 mg/l	ND
BOD	Report	8.6	Selenium	0.2 mg/l	ND
Cadmium	0.02 mg/l	ND	Zinc	1.2 mg/l	ND
Chromium, Hex	0.2 mg/l	ND	Barium	4.0 mg/l	0.47
Chromium, total	2.0 mg/l	ND	Phenol	4.0 mg/l	1.2
Copper	0.8 mg/l	ND	Sulfide	6.0 mg/l	ND
Cyanide, total	0.2 mg/l	ND	Manganese	4.0 mg/l	1.4
Lead	0.2 mg/l	ND	Gold	0.2 mg/l	ND
Mercury	0.1 mg/l	ND	pH	5.0-9.5 s.u.	6.25
Nickel	2.0 mg/l	ND	TSS	250 mg/l	64
Ignitability	>140°F	>150°F	Chlorine, avail.	50.0 mg/l	ND

**Certification Statement**

“I certify under penalty of law that this document and all attachments were prepared under my direction or supervision in accordance with a system designed to assure that qualified personnel properly gather and evaluate the information submitted. Based on my inquiry of the person or persons who manage the system, or those persons directly responsible for gathering the information, the information submitted is, to the best of my knowledge and belief, true, accurate, and complete. I am aware that there are significant penalties for submitting false information, including the possibility of fine and imprisonment for knowing violations.”

Respectfully submitted,

\_\_\_\_\_  
 Patrick J. Hines  
 Associate

MANWLANDFILE\monthly affirmation\23sk.doc

**REGIONAL OFFICES**

- 111 Wheatfield Drive • Milford, Pennsylvania 18337 • 570-296-2765 •
- 540 Broadway • Monticello, New York 12701 • 845-794-3399 •





**McGOEY, HAUSER and EDSALL**  
CONSULTING ENGINEERS P.C.

RICHARD D. McGOEY, P.E. (NY & PA)  
WILLIAM J. HAUSER, P.E. (NY & NJ)  
MARK J. EDSALL, P.E. (NY, NJ & PA)  
JAMES M. FARR, P.E. (NY & PA)

MAIN OFFICE  
33 Airport Center Drive  
Suite 202  
New Windsor, New York 12553

(845) 567-3100  
fax: (845) 567-3232  
e-mail: mheny@mhepc.com

Sample Date: 27 Sept. 2013  
Report Date: 13 Nov 2013

**Monitoring Report:** sample type is grab, frequency is quarterly

Parameter	Limit	Sample	Parameter	Limit	Sample
Arsenic	0.02 mg/l	ND	Silver	0.1 mg/l	ND
BOD	Report	23	Selenium	0.2 mg/l	ND
Cadmium	0.02 mg/l	ND	Zinc	1.2 mg/l	ND
Chromium, Hex	0.2 mg/l	ND	Barium	4.0 mg/l	0.6
Chromium, total	2.0 mg/l	ND	Phenol	4.0 mg/l	ND
Copper	0.8 mg/l	ND	Sulfide	6.0 mg/l	ND
Cyanide, total	0.2 mg/l	ND	Manganese	4.0 mg/l	1.6
Lead	0.2 mg/l	.008	Gold	0.2 mg/l	ND
Mercury	0.1 mg/l	ND	pH	5.0-9.5 s.u.	6.50
Nickel	2.0 mg/l	ND	TSS	250 mg/l	110
Ignitability	>140°F	>150°F	Chlorine, avail.	50.0 mg/l	ND

**Certification Statement**

"I certify under penalty of law that this document and all attachments were prepared under my direction or supervision in accordance with a system designed to assure that qualified personnel properly gather and evaluate the information submitted. Based on my inquiry of the person or persons who manage the system, or those persons directly responsible for gathering the information, the information submitted is, to the best of my knowledge and belief, true, accurate, and complete. I am aware that there are significant penalties for submitting false information, including the possibility of fine and imprisonment for knowing violations."

Respectfully submitted,

\_\_\_\_\_  
Patrick J. Hines  
Associate

M:\NWL\LANDFILL\monthly affirmation\23sk.doc

REGIONAL OFFICES

- 111 Wheatfield Drive • Milford, Pennsylvania 18337 • 570-296-2765 •
- 540 Broadway • Monticello, New York 12701 • 845-794-3399 •





**McGOEY, HAUSER and EDSALL**  
CONSULTING ENGINEERS P.C.

RICHARD D. McGOEY, P.E. (NY & PA)  
WILLIAM J. HAUSER, P.E. (NY & NJ)  
MARK J. EDSALL, P.E. (NY, NJ & PA)  
JAMES M. FARR, P.E. (NY & PA)

MAIN OFFICE  
33 Airport Center Drive  
Suite 202  
New Windsor, New York 12553

(845) 567-3100  
fax: (845) 567-3232  
e-mail: mheny@mhepc.com

Sample Date: 28 Feb. 2013  
Report Date: 29 April 2013

**Monitoring Report:** sample type is grab, frequency is quarterly

<u>Parameter</u>	<u>Limit</u>	<u>Sample</u>	<u>Parameter</u>	<u>Limit</u>	<u>Sample</u>
Arsenic	0.02 mg/l	ND	Silver	0.1 mg/l	ND
BOD	Report	22	Selenium	0.2 mg/l	ND
Cadmium	0.02 mg/l	ND	Zinc	1.2 mg/l	ND
Chromium, Hex	0.2 mg/l	ND	Barium	4.0 mg/l	0.33
Chromium, total	2.0 mg/l	ND	Phenol	4.0 mg/l	ND
Copper	0.8 mg/l	ND	Sulfide	6.0 mg/l	ND
Cyanide, total	0.2 mg/l	ND	Manganese	4.0 mg/l	1.2
Lead	0.2 mg/l	.008	Gold	0.2 mg/l	ND
Mercury	0.1 mg/l	ND	pH	5.0-9.5 s.u.	6.82
Nickel	2.0 mg/l	ND	TSS	250 mg/l	48
Ignitability	>140°F	>150°F	Chlorine, avail.	50.0 mg/l	ND

**Certification Statement**

“I certify under penalty of law that this document and all attachments were prepared under my direction or supervision in accordance with a system designed to assure that qualified personnel properly gather and evaluate the information submitted. Based on my inquiry of the person or persons who manage the system, or those persons directly responsible for gathering the information, the information submitted is, to the best of my knowledge and belief, true, accurate, and complete. I am aware that there are significant penalties for submitting false information, including the possibility of fine and imprisonment for knowing violations.”

Respectfully submitted,

\_\_\_\_\_  
Patrick J. Hines  
Associate

M:\NWL\LANDFILL\monthly affirmation\23sk.doc

REGIONAL OFFICES

- 111 Wheatfield Drive • Milford, Pennsylvania 18337 • 570-296-2765 •
- 540 Broadway • Monticello, New York 12701 • 845-794-3399 •





M.A. Day Engineering Stormwater Pollution  
Prevention Plan April 17, 2018



**Preliminary  
Stormwater Pollution  
Prevention Plan  
for  
935 Union Avenue  
Site Plan**

**Location:**

935 Union Avenue  
Town of New Windsor  
County of Orange  
NWPB No. 17-04

**Date:** April 17, 2018



3 Van Wyck Lane  
Suite 2  
Wappingers Falls, New York 12590  
Phone: 845-223-3202



## Table of Contents

<b>CERTIFICATION STATEMENTS .....</b>	<b>IV</b>
OWNER’S/OPERATOR’S CERTIFICATION .....	V
CONTRACTOR’S CERTIFICATION .....	VI
SUBCONTRACTOR’S CERTIFICATION .....	VII
QUALIFIED PROFESSIONAL’S CREDENTIALS AND CERTIFICATION .....	VIII
<b>1.0 INTRODUCTION .....</b>	<b>1</b>
1.1 PROJECT BACKGROUND .....	1
1.2 PROPOSED PROJECT .....	1
<b>2.0 EXISTING SITE FEATURES .....</b>	<b>2</b>
2.1 HISTORIC PLACES .....	3
2.2 SITE SOILS.....	3
<b>3.0 EXISTING SITE HYDROLOGY .....</b>	<b>4</b>
3.1 PRE DEVELOPMENT DRAINAGE AREAS.....	5
3.2 PRE DEVELOPMENT RUNOFF FLOW RATES .....	6
<b>4.0 DEVELOPED SITE HYDROLOGY.....</b>	<b>6</b>
4.1 THE SIX STEP PROCESS FOR STORMWATER SITE PLANNING AND PRACTICE SELECTION.....	7
4.1 POST DEVELOPMENT DRAINAGE AREAS.....	9
4.2 POST DEVELOPMENT RUNOFF FLOW RATE.....	9
4.3 PRE VS. POST RUNOFF FLOW RATES .....	9
4.3.1 DP#1.....	9
4.3.2 DP#2.....	10
4.3.2 Mitigation Measures.....	10
<b>5.0 PERMANENT WATER QUALITY &amp; QUANTITY CONTROLS.....</b>	<b>11</b>
5.1 WATER QUALITY VOLUME .....	11
5.2 RUNOFF REDUCTION VOLUME (RRV).....	13
<b>6.0 TEMPORARY EROSION &amp; SEDIMENT CONTROL MEASURES .....</b>	<b>14</b>
6.1 SILT FENCE:.....	15
6.2 CONSTRUCTION ENTRANCE: .....	19
6.3 DUST CONTROL: .....	23
<b>7.0 PERMANENT EROSION &amp; SEDIMENT CONTROL MEASURES.....</b>	<b>26</b>
7.1 LANDGRADING:.....	26
<b>8.0 CONSTRUCTION SCHEDULE .....</b>	<b>31</b>





8.1	PRE-CONSTRUCTION SCHEDULE (DUPLICATE ON SWPPP PLAN SHEET) .....	31
8.2	CONSTRUCTION SCHEDULE (DUPLICATE ON SWPPP PLAN SHEET) .....	31
8.3	CONSTRUCTION WASTE MANAGEMENT PLAN .....	32
<b>9.0</b>	<b>CONCLUSIONS .....</b>	<b>34</b>

### **LIST OF FIGURES**

Figure A	- Location Map .....	2
Figure B	- Soils Map.....	4
Figure C	- USGS Map.....	5
Figure D	- 90% Rainfall in New York State .....	12
Figure I	- Landgrading Detail.....	29
Figure J	- Landgrading Construction Specifications Detail .....	30

### **LIST OF TABLES**

Table 1:	Pre Development Drainage Area Input Summary .....	6
Table 2:	Pre Development Hydrograph Summary .....	6
Table 3:	Post Development Drainage Input Summary .....	9
Table 4:	Post Development Hydrograph Summary .....	9
Table 5:	Pre vs. Post Summary for DP#1.....	10
Table 6:	Pre vs. Post Summary for DP#2.....	10
Table 7:	Silt Fence Requirements .....	16
Table 8:	Criteria for Geotextile Material in Construction Entrance.....	20

### **APPENDIX**

Pre-Development Cn, Tc Calculations .....	A
Pre-Development Hydrographs & Summary .....	A
Post-Development Cn, Tc Calculations.....	B
Post-Development Hydrographs & Summary .....	B
Unified Sizing Criteria Calculations.....	C
SPDES General Permit .....	D
Notice of Intent (NOI) .....	E
MS4 Stormwater Pollution Prevention Plan (SWPPP) Acceptance Form .....	F
Notice of Termination (NOT).....	G
Pre & Post Hydrology.....	H
SWPPP Plan & Details .....	I
Stormtech SC-740 Construction Guide and O&M Manual .....	J
Construction Inspection Log Book .....	K





## Certification Statements





### Owner's/Operator's Certification

"I certify under penalty of law that this document and all attachments were prepared under my direction or supervision in accordance with a system designed to assure that qualified personnel properly gather and evaluated the information submitted. Based on my inquiry of the persons or persons who manage the system, or those persons directly responsible for gathering the information, the information submitted is, to the best of my knowledge and belief, true, accurate, and complete. Further, I hereby certify that the SWPPP meets all Federal, State, and local erosion and sediment control requirements. I am aware that false statements made herein are punishable as a class A misdemeanor pursuant to Section 210.45 of the Penal Law."

Name (please print) \_\_\_\_\_

Title \_\_\_\_\_ Date \_\_\_\_\_

Address \_\_\_\_\_

Phone \_\_\_\_\_ Email \_\_\_\_\_

Signature \_\_\_\_\_







### Contractor's Certification

"I hereby certify that I understand and agree to comply with the terms and conditions of the SWPPP and agree to implement any corrective actions identified by the qualified inspector during a site inspection. I also understand that the owner or operator must comply with the terms and conditions of the New York State Pollutant Discharge Elimination System ("SPDES") general permit for stormwater discharges from construction activities and that it is unlawful for any person to cause or contribute to a violation of water quality standards. Furthermore, I understand that certifying false, incorrect or inaccurate information is a violation of the referenced permit and the laws of State of New York and could subject me to criminal, civil and/or administrative proceedings."

**Contracting Firm Name** (please print) \_\_\_\_\_

**Address** \_\_\_\_\_

**Phone** \_\_\_\_\_ **Fax** \_\_\_\_\_

**Name** (please print) \_\_\_\_\_

**Title** \_\_\_\_\_ **Date** \_\_\_\_\_

**Signature** \_\_\_\_\_

**SWPPP Responsibilities** \_\_\_\_\_

\_\_\_\_\_  
\_\_\_\_\_  
\_\_\_\_\_

**Trained Individual Name** (please print) \_\_\_\_\_

**Title** \_\_\_\_\_ **Date** \_\_\_\_\_

**Signature** \_\_\_\_\_

**SWPPP Responsibilities** \_\_\_\_\_

\_\_\_\_\_  
\_\_\_\_\_

Note: All contractors involved with Stormwater related activities shall sign a contractor's certification form.





### Subcontractor's Certification

"I hereby certify that I understand and agree to comply with the terms and conditions of the SWPPP and agree to implement any corrective actions identified by the qualified inspector during a site inspection. I also understand that the owner or operator must comply with the terms and conditions of the New York State Pollutant Discharge Elimination System ("SPDES") general permit for stormwater discharges from construction activities and that it is unlawful for any person to cause or contribute to a violation of water quality standards. Furthermore, I understand that certifying false, incorrect or inaccurate information is a violation of the referenced permit and the laws of State of New York and could subject me to criminal, civil and/or administrative proceedings."

**Subcontracting Firm Name** (please print) \_\_\_\_\_

**Address** \_\_\_\_\_

**Phone** \_\_\_\_\_ **Fax** \_\_\_\_\_

**Name** (please print) \_\_\_\_\_

**Title** \_\_\_\_\_ **Date** \_\_\_\_\_

**Signature** \_\_\_\_\_

**SWPPP Responsibilities** \_\_\_\_\_

\_\_\_\_\_

\_\_\_\_\_

**Trained Individual Name** (please print) \_\_\_\_\_

**Title** \_\_\_\_\_ **Date** \_\_\_\_\_

**Signature** \_\_\_\_\_

**SWPPP Responsibilities** \_\_\_\_\_

\_\_\_\_\_

\_\_\_\_\_

Note: All contractors involved with Stormwater related activities shall sign a contractor's certification form.





## Qualified Professional's Credentials and Certification

"I hereby certify that I meet the criteria set forth in the General Permit to conduct site inspections for this project and that the appropriate erosion and sediment controls described in the SWPPP and as described in the following Pre-Construction Site Assessment Checklist have been adequately installed or implemented, ensuring the overall preparedness of this site for the commencement of construction."

Name (please print) \_\_\_\_\_

Title \_\_\_\_\_ Date \_\_\_\_\_

Address \_\_\_\_\_

Phone \_\_\_\_\_ Email \_\_\_\_\_

Signature \_\_\_\_\_

"Qualified Professional" means a person knowledgeable in the principles and practices of erosion and sediment controls, such as a Certified Professional in Erosion and Sediment Control (CPESC), soil scientist, licensed engineer or someone working under the direction and supervision of a licensed engineer (person must have experience in the principles and practices of erosion and sediment control).



## **1.0 Introduction**

This Stormwater Pollution Prevention Plan (SWPPP) for the site to be known as “935 Union Avenue” has been developed in accordance with New York State Department of Environmental Conservation (NYSDEC) technical standards as presented in the New York Standards and Specifications for Sediment and Erosion Control Manual (July 2016), and the New York State Stormwater Management Design Manual (August 2015). This report has also been designed to meet the criteria requirements of the New York State Pollutant Discharge Elimination System (SPDES) General Permit GP-0-15-002.

### **1.1 Project Background**

The subject property is a 2.81-acre parcel located at 935 Union Avenue (a.k.a. Route 300) in the Town of New Windsor, Orange County, New York. The tax map parcel no. is 4-1-12.11.

The site is located south of Interstate 84 by approximately 1.4 miles, 4,300 feet south of the intersection with Route 17K and west of the NYS Thruway by approximately 780’. The project is also due west of the Lake Washington which is on the opposite side of Union Avenue. The intersection of Liner Road is directly adjacent to the property on the north side. Liner Road abuts the project site on the north and west side of the property. The project site is approximately 3,000’ north of Little Britain Road. The project site is also located approximately 1,000’ south of the town line with the Town of Newburgh.

A location map has been provided in Figure A below, which shows an aerial view of the site and the surrounding area.

### **1.2 Proposed Project**

The Proposed Action involves the removal of an existing 5,575 square foot, wood-frame & masonry building and constructing a four-story limited-service hotel with 93 rooms and requisite parking on the site. The site will be landscaped with proper lighting and a re-aligned single entrance onto Union Avenue. The access to the south of the property will remain with minor improvements

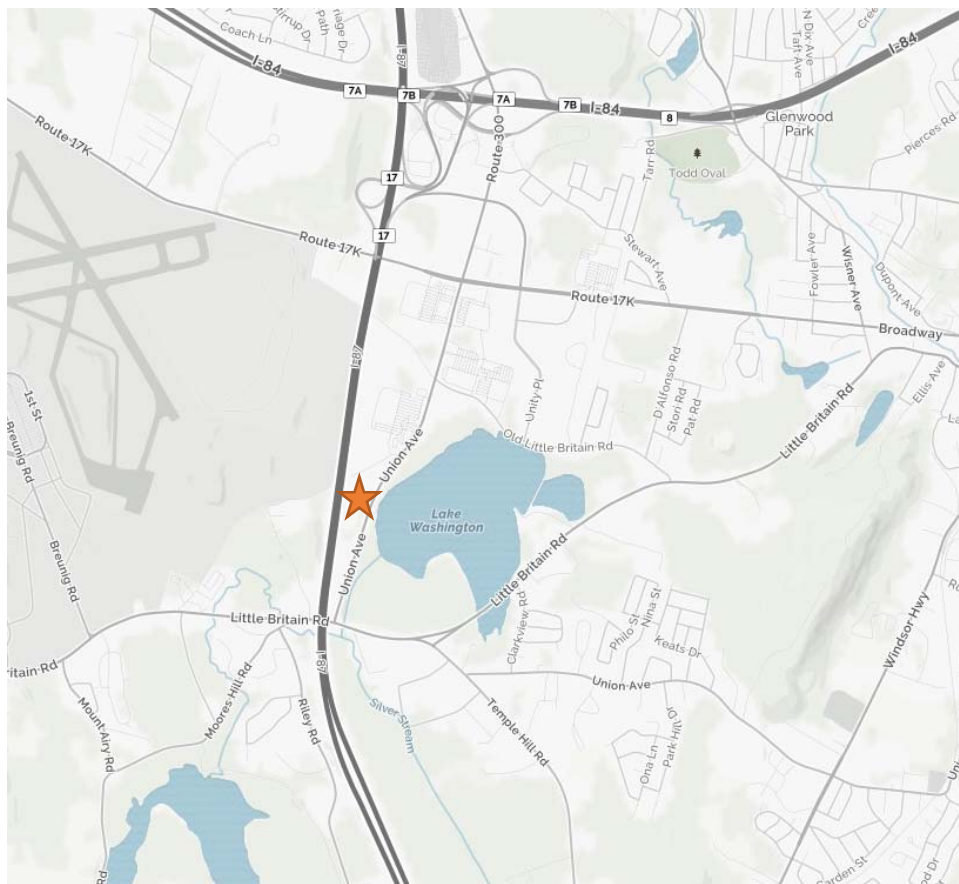
The storm water management practices that are being proposed herein are to satisfy both the requirements for water quality and quantity. Please refer to section 5.0, “Permanent Water Quality and Quantity Controls,” of this report for further information.

According to the NY SPDES General Permit, a SWPPP must be implemented for any project greater than one (1) acre of disturbance. The total disturbance for this project will be greater



than 1.0 acre threshold, therefore a complete SWPPP shall be provided. Disturbance to the site during construction will be minimized to every extent possible. Temporary erosion and sediment control measures have been provided and locations have been shown on the plan to indicate the limits of disturbance and to delineate the areas deemed necessary for re-grading and clearing during construction. This report has been designed to offer both temporary and permanent mitigation practices during and after the construction phase in an effort to reduce the sediment laden runoff created by the disturbed areas.

Figure A - Location Map



Source: Google Earth

## 2.0 Existing Site Features

The site currently contains a vacant 5,575 square foot wood-frame and masonry building that is the former location of the Banta's Steak and Stein restaurant. The site has been vacant for approximately 2 years. The site contains pavement, exterior lighting and other improvements that were once used by the restaurant.

## 2.1 Historic Places

Base on the New York State Historic Preservation Office (SHPO) National Register and Archeological Sensitivity Map, the site is not located within an archeo sensitive area.

## 2.2 Site Soils

The official soil types indicated by the USDA Soil Conservation Service, "Soil Survey of Orange County, New York" lists the site soils to be "Mardin" MdB and a small area to the south identified as "Qu" or former quarry sites. The quarried area appears to be south of the existing diner.

### MdB - Mardin soils (57%)

Hydrologic Soil group: D

Description: This Deep, moderately well drained, gently sloping soil formed in glacial till deposits derived for sandstone shale and slate.

Typical profile

- Ap - 0 to 8 inches: gravelly silt loam
- Bw - 8 to 15 inches: gravelly silt loam
- E - 15 to 20 inches: gravelly silt loam
- Bx - 20 to 72 inches: gravelly silt loam

### Qu – Quarries (43%)

Hydrologic Soil group: N/A

Description: Quarries are excavation into various kinds of bedrock including shale, slate, limestone and granitic gness. The rock material has been removed for road subgrade and other construction purposed. There are no visible rock outcroppings on the site.

Refer to the following site soil descriptions and soils map in Figure B for the soil conditions presently found on the site

Figure B - Soils Map

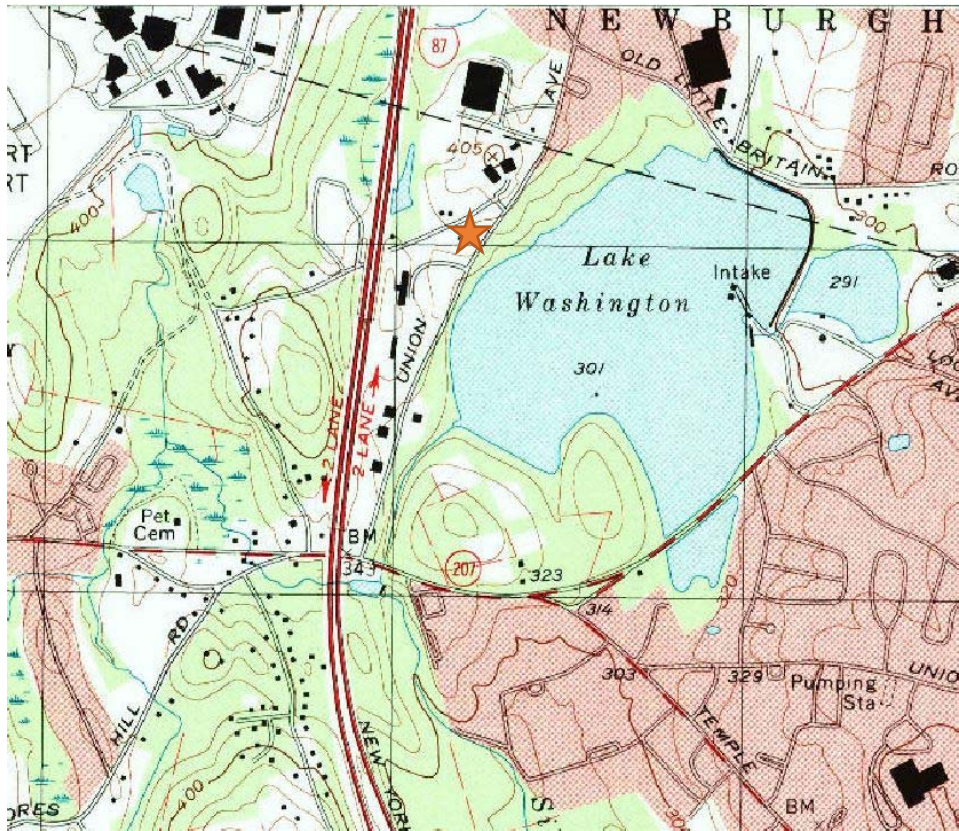


Source: USDA Natural Resource Conservation Service Web Soil Survey

### 3.0 Existing Site Hydrology

The site in the pre-development condition consists of wooded, grassland ground and impervious cover. Due to the natural topography of the land, the site drains toward south of the site, where it is intersected by an existing stormsewer which discharges into Lake Antrim. Refer to Figure C for a topographical map of the site.

Figure C - USGS Map



Source: USGS Cornwall-on-Hudson Quadrangle New York 7.5 Minute Series

### 3.1 Pre Development Drainage Areas

The water shed for the project site is approximately 3.10 acres which includes the proposed project site and portions of parcel to the west, owned by Windsor Hospitality, LLC.

The water shed has been broken into two drainage area to more accurately analyze the stormwater runoff in the pre-development conditions.

Drainage Area 1 (DA#1) is 2.81 acres encompasses the western portions of the site along with small portion of the Windsor Hospitality site. A single Design Point (DP#1) located at the existing drainage manhole within the Union Avenue (NYS Route 300) Right-of-way. The majority of the runoff is overland flow from the existing building and parking lot areas. This flow is intercepted by an existing 12 inch RCP pipe along the southwest property boundary which discharges to the existing storm sewer system along the southerly property boundary, which ultimately discharges to DP#1.

Drainage Area 2 (DA#2) is 0.29 acres and consists of small grass/woodland portions of the project site. The runoff consists of overland flow which is collected by an existing 12 inch RCP pipe within the Union Avenue Right-of-way.



Refer to Appendix “A” for a detailed calculation of the Area, CN and  $T_c$  values. A summary of the pre development drainage input calculations can be found in Table 1 below.

Table 1: Pre Development Drainage Area Input Summary

Area	Total Area (Acres)	CN	$T_c$ (minutes)
DA#1	2.81	90	12.8
DA#2	0.29	82	11.0

### 3.2 Pre Development Runoff Flow Rates

The pre development runoff rates were calculated using the Area, CN and  $T_c$  values as shown above. These values were then entered into HydroCAD, 1 and 2, 10, 25, & 100-year storm event flow rate values were obtained for a Type-III storm distribution. Refer to Appendix “A” for pre development hydrographs.

The following table is a summary of the pre development design flows:

Table 2: Pre Development Hydrograph Summary

Design Point	1-year Event	2-Year Event	10-Year Event	25-Year Event	100-Year Event
DP#1	4.62 c.f.s.	5.93 c.f.s.	9.10 c.f.s.	11.69 c.f.s.	16.37 c.f.s.
DP#2	0.34 c.f.s.	0.47 c.f.s.	0.82 c.f.s.	1.10 c.f.s.	1.64 c.f.s.

## 4.0 Developed Site Hydrology

The site in the post-development build out condition will consist of a 93-room hotel. Other development on this site will include the construction roadways, parking areas, retaining walls and various land-grading and landscaping. Ground cover changes will include wooded areas being converted to impervious and grassed lawn areas. Construction and regrading on the site will alter the existing topography and will therefore change the existing drainage patterns. While the same design point that was analyzed in the pre-development condition will be analyzed in the post-development condition, the drainage area and flow will be altered due to the improvements on the site.

Please refer to Drainage Sheet 2 of 2, “Post Development Hydrology”, included in the back of this report, for graphical representations of drainage flow paths and areas.

## **4.1 The Six Step Process for Stormwater Site Planning and Practice Selection**

### **4.1.1 Site Planning**

During the planning process, many green aspects have been incorporated into the site layout. Some of these practices include the preservation of natural features and the reduction of impervious cover.

#### **4.1.1.1 Preservation of Natural Resources**

The following measures have been incorporated into the site design to preserve natural resources.

- **Preservation of Undisturbed Areas** – of the 3.01 acres, 1.02 acres will remain with the existing lot and will remain undeveloped as part of this application.
- **Reduction of Clearing and Grading** - The site has been designed with the intent to limit clearing and grading required to the minimum amount necessary.

#### **4.1.1.2 Reduction of Impervious Cover**

Throughout the site an effort has been made to reduce the amount of impervious cover proposed by this project.

#### **4.1.1.3 Runoff Reduction Techniques**

The site has been designed to manage the impacts by using runoff reduction practices that promote infiltration. Runoff from the site will be directed to underground infiltration basin located under the parking areas and drive aisle on the site. This will allow for stormwater runoff to infiltrate into the surrounding soil.

### **4.1.2 Determine Water Quality Treatment Volumes (WQv)**

The required WQv have been calculation in accordance with Chapter 4: Unified Stormwater Sizing Criteria of the New York State Stormwater Management Design Manual January 2015. Please refer to section 5.0, "Permanent Water Quality and Quantity Controls," of this report for further information

### 4.1.3 Apply Runoff Reduction Techniques and Standard SMPs with RRV Capacity

The standard SMPs with RRV capacity are listed in table 3.5. The following percentages for WQv (provided by the standard SMP) towards meeting the RRV sizing criteria

Runoff Reduction Capacity for Standard SMPs	
SMP	RRv Capacity (% of WQv Provided by Parctice)
Infiltration Practice	100%
Bioretention Practice	100% in HSG A & B (without underdrain)
	40% in HSG C & D (with underdrain)
Dry Swale	40% in HSG A & B
	20% in HSG C & D

By applying a combination of green infrastructure techniques and standard SMPs with RRV capacity, the design must reduce 100% of the WQv calculated in Step 2. If the RRV calculated in this step is greater than or equal to the WQv calculated in Step 2, the design has met the RRV requirements and may proceed to Step 5.

### 4.1.4 Determine the minimum RRV required – Refer to Section 5.0

### 4.1.5 Apply Standard Stormwater Management Practices to Address Remaining Water Quality Volumes

100% of the WQv water quality volume requirement has been addressed by applying the green infrastructure technique and standard SMP's with RRV capacity.

### 4.1.6 Apply Volume and Peak Rate Control Practices if Still Needed to Meet Requirements.

The post-development peak flow rates for the required Channel Protect Storage Volume (CPv), Overbank Flood (Qp) and the Extreme Flood (Qf) control can be found in Section 6 Unified Stormwater Sizing Criteria.



## 4.1 Post Development Drainage Areas

The drainage area contributing runoff to DP#1 in the post-development condition has been broken down into three smaller sub-areas to properly analyze the overall drainage impacts at DP#1. Sub-areas shall consist of portions of the site where development is to take place and will therefore contain a stormwater management practice (SMP) to properly mitigate runoff for that area. Please refer to Appendix “B” for a detailed calculation of the Area, CN and  $T_c$  values. A summary of the post development drainage input can be found below in Table 5.

Table 3: Post Development Drainage Input Summary

Sub-Area	Total Area (acres)	CN	$T_c$ (minutes)
DA#1	0.32	82	9.9
DA#1A	1.08	88	6.0*
DA#1B	1.77	91	6.0*
DA#2	0.04	82	6.3

## 4.2 Post Development Runoff Flow Rate

The post development runoff rates were calculated using the Area, CN and  $T_c$  values obtained as shown in the chart in above. These values were entered into HydroCAD, and 2, 10, 25, & 100-year storm flow rate values were obtained for a Type-III storm distribution. Please refer to the Appendix “B” for the hydrographs for sub-areas. Refer to the following chart for a summary of the post development design flows:

Table 4: Post Development Hydrograph Summary

Design Pont	1-Year Event	2-Year Event	10-Year Event	25-Year Event	100-Year Event
DP#1	0.38 c.f.s.	0.54 c.f.s.	4.03 c.f.s.	8.55 c.f.s.	14.39 c.f.s.
DP#2	0.06 c.f.s.	0.08 c.f.s.	0.15 c.f.s.	0.20 c.f.s.	0.30 c.f.s.

## 4.3 Pre vs. Post Runoff Flow Rates

### 4.3.1 DP#1

Design point #1 will experience a net decrease in area, and therefore a decreasing stormwater runoff will occur between the pre and post development conditions. Please refer to Table 5 for a summary of the Pre vs. Post flow rates.

Table 5: Pre vs. Post Summary for DP#1

Storm	Pre	Post	Delta
1-year	4.62 c.f.s.	0.38 c.f.s.	-4.24 c.f.s.
2-year	5.93 c.f.s.	0.54 c.f.s.	-5.39 c.f.s.
10-year	9.10 c.f.s.	4.03 c.f.s.	-5.07 c.f.s.
25-year	11.69 c.f.s.	8.55 c.f.s.	-3.14 c.f.s.
100-year	16.37 c.f.s.	14.39 c.f.s.	-1.98 c.f.s.

### 4.3.2 DP#2

Design point #2 will experience a net decrease in area, and therefore a decreasing stormwater runoff will occur between the pre and post development conditions.

Please refer to Table 5 for a summary of the Pre vs. Post flow rates.

Table 6: Pre vs. Post Summary for DP#2

Storm	Pre	Post	Delta
1-year	0.34 c.f.s.	0.06 c.f.s.	-0.28 c.f.s.
2-year	0.47 c.f.s.	0.08 c.f.s.	-0.39 c.f.s.
10-year	0.82 c.f.s.	0.15 c.f.s.	-0.67 c.f.s.
25-year	1.10 c.f.s.	0.20 c.f.s.	-0.90 c.f.s.
100-year	1.64 c.f.s.	0.30 c.f.s.	-1.34 c.f.s.

### 4.3.2 Mitigation Measures

#### Underground Infiltration Bastions

StormTech stormwater infiltration systems will be installed beneath the parking area as mitigation for the WQv quantity and will allow for infiltration of stormwater into the surrounding soils. The system will consist of an “Isolator Rows” to provide pretreatment and a series of standard StormTech chambers for quantity. The StormTech “Isolator Row” is a row of standard StormTech chambers surrounded with appropriate filter fabrics. Runoff will be first entering the Isolator Row via a manhole at the upstream end of the system. An outlet control structure will regulate the flow out of the system via an overflow weir. The overflow weir with the height set

at even with the top the chambers allows stormwater in excess of the storage capacity to bypass into the existing storm sewer system.

The “StormTech” system being proposed on this site is to help mitigate stormwater peak flows to below pre-development conditions. Each system has a specific “foot print” of crushed stone and number of “StormTech SC-740”. The chambers will be set on top of a 18” stone bed and will also be placed between and on 9” top of the chambers. The runoff will enter the system through a 48” diameter manhole.

Deep Test Pits and field percolation will need to be performed in accordance with Appendix D of the Stormwater Management Design Manual. For the purpose of this report, an exfiltration rate of 15 inches per hour was use for the preliminary design of the system.

## 5.0 Permanent Water Quality & Quantity Controls

The New York State Stormwater Management Design Manual outlines the guidelines, requirements and waivers for implementation of permanent water quality and quantity control measures on a given constructions site. The unified stormwater sizing criteria has been used to develop stormwater management practices (SMP’s) that meet pollutant removal goals, reduce channel erosion, prevent overbank flooding, and help control extreme floods.

Since the drainage area for DP#1 experiences an increase in impervious area in the post development condition, the use of stormwater management practices is required. Stormwater management basin systems are being proposed to satisfy the requirements for water quality. In accordance with Chapter 4: Unified Stormwater Sizing Criteria of the New York State Stormwater Management Design Manual June 2016, channel protection for redevelopment activities is not required if there are no changes to the hydrology that increase the discharge rate from the site. As noted in table 5 above there will be no increase in the discharge rate from the site therefor the Stream Channel Protection Volume Requirements ( $C_{p_v}$ ), Overbank Flood Control Criteria ( $Q_p$ ), and Extreme Flood Control Criteria ( $Q_f$ ) does not apply. Water quality ( $WQ_v$ ), volumes, shall all be accounted for within the proposed stormwater management basin system. The following is an outline of the criteria for the stormwater management practices of this project site.

### 5.1 Water Quality Volume

The Water Quality Volume ( $WQ_v$ ) is designed to improve water quality and is sized to capture and treat 90% of the average annual stormwater runoff volume. The  $WQ_v$  is directly related to the amount of impervious cover created on a site. Water quality storage volume can be calculated using the following equation:

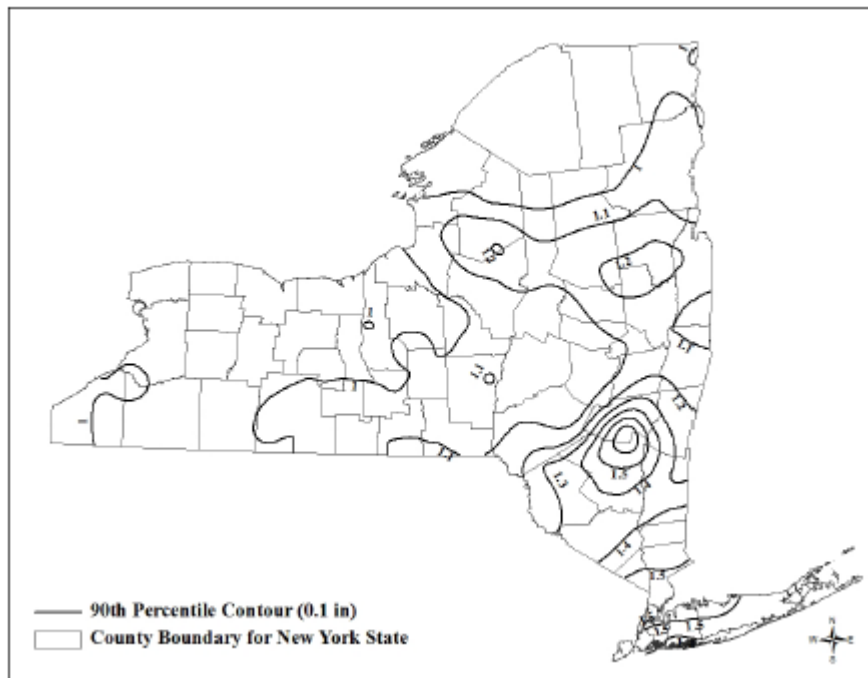
$$WQ_v = \frac{(P)(R_v)(A)}{12}$$

Where:

- WQ<sub>v</sub> = Water Quality Volume (acre-feet)
- P = 1.5 (Using Figure D - 90% Rainfall Event Number)
- R<sub>v</sub> = 0.05 + 0.009(I), where I is percent impervious cover
- A = Contributing area (acres)

Figure D – 90% Rainfall in New York State

Figure 4.1: 90th Percentile Rainfall in New York State (NYSDEC, 2013)



Total required WQ<sub>v</sub> for sub-area 1A = 0.040 ac-ft. (1,760 ft<sup>3</sup>)

Total provided WQ<sub>v</sub> for sub-area 1A = 0.10 ac-ft. (4,758 ft<sup>3</sup>)

Total required WQ<sub>v</sub> for sub-area 1B = 0.092 ac-ft. (4,030 ft<sup>3</sup>)

Total provided WQ<sub>v</sub> for sub-area 1B = 0.095 ac-ft. (4,181 ft<sup>3</sup>)

The calculations can be found in Appendix E.

## 5.2 Runoff Reduction Volume (RR<sub>v</sub>)

Runoff Reduction Volume is the reduction of the total WQ<sub>v</sub> by application of green infrastructure techniques and SMPs to replicate pre-development hydrology. The minimum required RR<sub>v</sub> is defined as the Specified Reduction Factor (S), provided objective technical justification is documented. Runoff reduction shall be achieved by infiltration, groundwater recharge, reuse, recycle, evaporation/evapotranspiration of 100 percent of the post-development water quality volumes to replicate pre-development hydrology by maintaining pre-construction infiltration, peak runoff flow, discharge volume, as well as minimizing concentrated flow by using runoff control techniques to provide treatment in a distributed manner before runoff reaches the collection system.. This requirement can be accomplished by application of on-site green infrastructure techniques, standard stormwater management practices with runoff reduction capacity, and good operation and maintenance.

The total available volume provided by the underground Infiltration basin systems are

Total required RR<sub>v</sub> for sub-area 1A = 0.040 ac-ft. (1,760 ft<sup>3</sup>)

Total provided RR<sub>v</sub> for sub-area 1A = 0.10 ac-ft. (4,758 ft<sup>3</sup>)

Total required RR<sub>v</sub> for sub-area 1B = 0.092 ac-ft. (4,030 ft<sup>3</sup>)

Total provided RR<sub>v</sub> for sub-area 1B = 0.095 ac-ft. (4,181 ft<sup>3</sup>)

The calculations can be found in Appendix C

## 6.0 Temporary Erosion & Sediment Control Measures

This SWPPP adheres to the erosion and sediment control requirements as described in the New York State Standards and Specifications for Erosion and Sediment Control. Construction on the project site involves the disturbance of greater than one (1) acre of soil and, therefore, requires GP-0-15-002 permit coverage. Coverage under this permit requires that a comprehensive Erosion and Sediment Control Plan be developed for the site during the construction phase. Please refer to the following items concerning temporary erosion & sediment control practices:

**STANDARDS AND SPECIFICATIONS  
FOR  
SILT FENCE**



**6.1 Silt Fence:**

All silt fencing locations have been shown on the SWPPP insert in the back of this report and shall be installed in accordance with the detail shown in Figure F below:

**Definition**

A temporary barrier of geotextile fabric installed on the contours across a slope used to intercept sediment laden runoff from small drainage areas of disturbed soil.

**Purpose**

The purpose of a silt fence is to reduce runoff velocity and effect deposition of transported sediment load. Limits imposed by ultraviolet stability of the fabric will dictate the maximum period the silt fence may be used (approximately one year).

**Conditions Where Practice Applies**

A silt fence may be used subject to the following conditions:

1. Maximum allowable slope lengths contributing runoff to a silt fence placed on a slope are:

<u>Slope Maximum</u>	<u>Steepness Length (ft.)</u>
2:1	25
3:1	50
4:1	75
5:1 or flatter	100

2. Maximum drainage area for overland flow to a silt fence shall not exceed ¼ acre per 100 feet of fence, with maximum ponding depth of 1.5 feet behind the fence.



3. Erosion would occur in the form of sheet erosion.
4. There is no concentration of water flowing to the barrier.

**Design Criteria**

Design computations are not required for installations of 1 month or less. Longer installation periods should be designed for expected runoff. All silt fences shall be placed as close to the areas as possible, but at least 10 feet from the toe of a slope to allow for maintenance and roll down. The area beyond the fence must be undisturbed or stabilized. Sensitive areas to be protected by silt fence may need to be reinforced by using heavy wire fencing for added support to prevent collapse. Where ends of filter cloth come together, they shall be overlapped, folded and stapled to prevent sediment bypass. A detail of the silt fence shall be shown on the plan. See Figure below for details.

**Criteria for Silt Fence Materials**

1. Silt Fence Fabric: The fabric shall meet the following specifications unless otherwise approved by the appropriate erosion and sediment control plan approval authority. Such approval shall not constitute statewide acceptance.

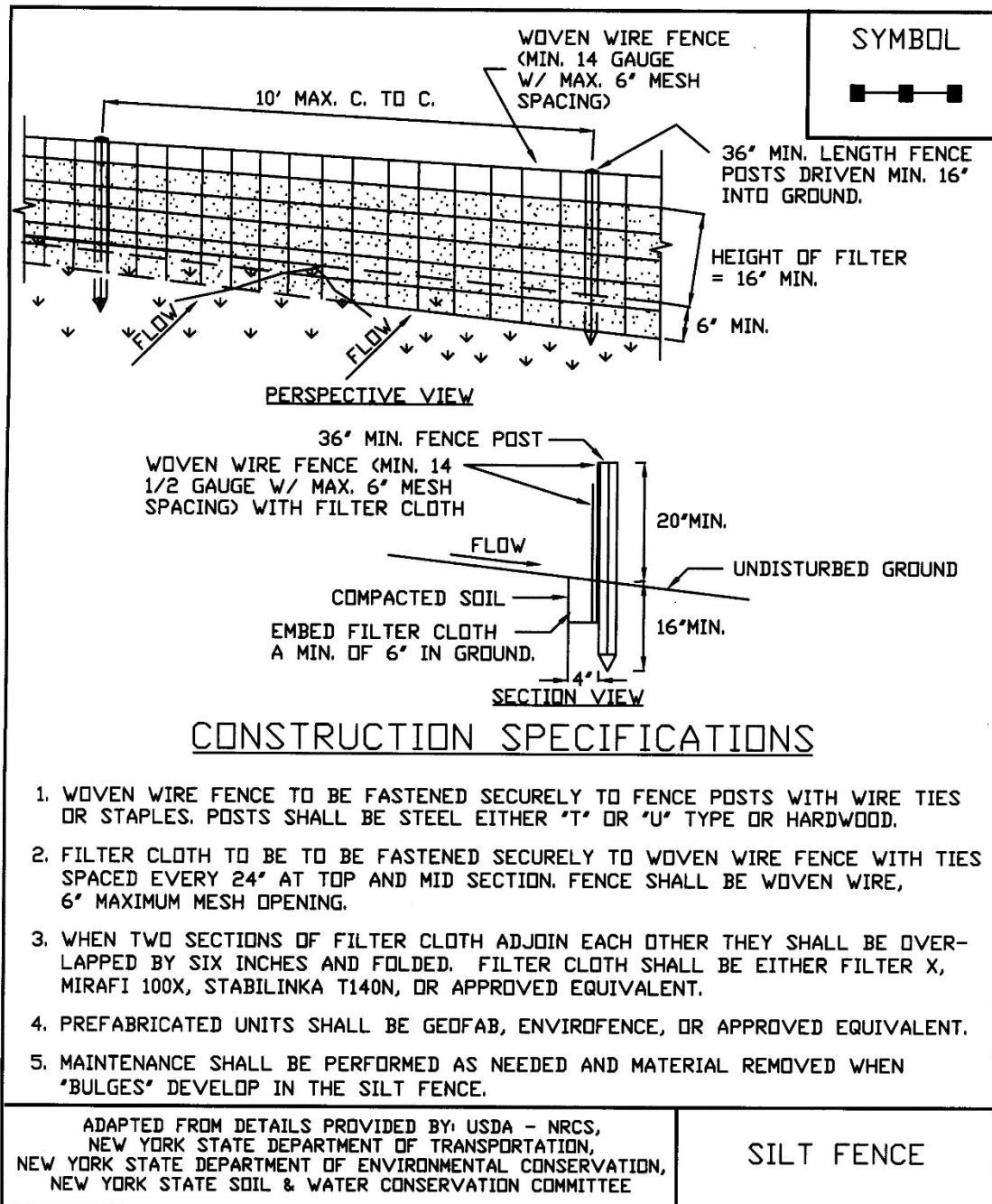
Table 7: Silt Fence Requirements

<b>Fabric Properties</b>	<b>Acceptable Value</b>	<b>Test Method</b>
Grab Tensile Strength (lbs)	90	ASTM D1682
Elongation at Failure (%)	50	ASTM D1682
Mullen Burst Strength (PSI)	190	ASTM D3786
Puncture Strength (lbs)	40	ASTM D751 (modified)
Slurry Flow Rate (gal/min/sf)	0.3	
Equivalent Opening Size	40-80	US Std Sieve CW-02215
Ultraviolet Radiation Stability (%)	90	ASTM G-26

2. Fence Posts (for fabricated units): The length shall be a minimum of 36 inches long. Wood posts will be of sound quality hardwood with a minimum cross sectional area of 2 square inches. Steel posts will be standard T and U section weighing not less than 1.00 pound per linear foot.

3. Wire Fence (for fabricated units): Wire fencing shall be a minimum 14 gage with a maximum 6 in. mesh opening, or as approved.
4. Prefabricated Units: Envirofence, Geofab, or approved equal, may be used in lieu of the above method providing the unit is installed per the detail shown below

Figure E - Silt Fence Detail



**STANDARD AND SPECIFICATIONS  
FOR  
STABILIZED CONSTRUCTION ENTRANCE**



**6.2 Construction Entrance:**

A construction entrance location has been shown on the SWPPP insert in the back of this report and shall be installed and maintained in accordance with the detail shown in Figure I below; until such time that the driveway has been stabilized by pavement.

**Definition**

A stabilized pad of aggregate underlain with geotextile located at any point where traffic will be entering or leaving a construction site to or from a public right-of-way, street, alley, sidewalk, or parking area.

**Purpose**

The purpose of stabilized construction entrance is to reduce or eliminate the tracking of sediment onto public rights-of way or streets.

**Conditions Where Practice Applies**

A stabilized construction entrance shall be used at all points of construction ingress and egress.

**Design Criteria**

**Aggregate Size:** Use a matrix of 1-4 inch stone, or reclaimed or recycled concrete equivalent.

**Thickness:** Not less than six (6) inches.

**Width:** 12-foot minimum but not less than the full width of points where ingress or egress occurs.

24-foot minimum if there is only one access to the site.

**Length:** As required, but not less than 50 feet (except on a single residence lot where a 30 foot minimum would apply).

**Geotextile:** To be placed over the entire area to be covered with aggregate. Filter cloth will not be required on a single-family residence lot. Piping of surface water under entrance shall be provided as required. If piping is impossible, a mountable berm with 5:1 slopes will be permitted.

**Criteria for Geotextile**

The geotextile shall be woven or non-woven fabric consisting only of continuous chain polymeric filaments or yarns of polyester. The fabric shall be inert to commonly encountered chemicals, hydro-carbons, mildew, rot resistant, and conform to the fabric properties as shown

Table 8: Criteria for Geotextile Material in Construction Entrance

<u>Fabric Properties</u> <sup>3</sup>	Light Duty <sup>1</sup> Roads Grade <u>Subgrade</u>	Heavy Duty <sup>2</sup> Haul Roads Rough <u>Graded</u>	<u>Test Method</u>
Grab Tensile Strength (lbs)	200	220	ASTM D1682
Elongation at Failure (%)	50	60	ASTM D1682
Mullen Brust Strength (lbs)	190	430	ASTM D3786
Puncture Strength (lbs)	40	125	ASTM D751 modified
Equivalent Opening Size	40-80	40-80	US Std Sieve CW-02215
Aggregate Depth	6	10	--

<sup>1</sup> Light Duty Road: Area sites that have been graded to subgrade and where most travel would be single axle vehicles and an occasional multi-axle truck. Acceptable materials are Trevira Spunbond 1115, Mirafi 100X, Typar 3401, or equivalent.

<sup>2</sup> Heavy Duty Road: Area sites with only rough grading, and where most travel would be multi-axle vehicles. Acceptable materials are Trevira Spunbond 1135, Mirafi 600X, or equivalent.

<sup>3</sup> Fabrics not meeting these specifications may be used only when design procedure and supporting documentation are supplied to determine aggregate depth and fabric strength.

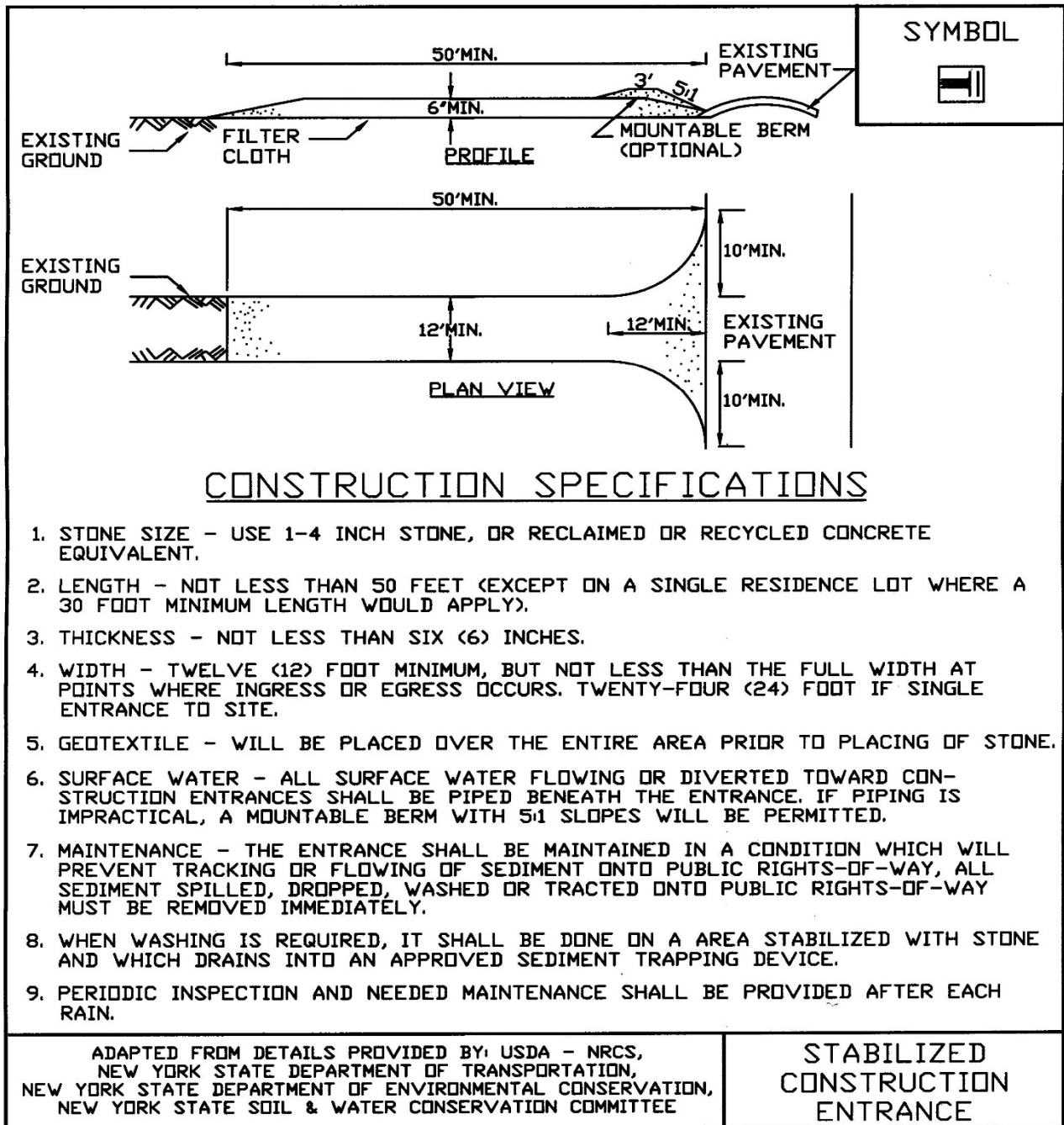
**Maintenance**

The entrance shall be maintained in a condition which will prevent tracking of sediment onto public rights-of-way or streets. This may require periodic top dressing with additional aggregate. All sediment spilled, dropped, or washed onto public rights-of-way must be removed immediately. When necessary, wheels must be cleaned to remove sediment prior to entrance



onto public rights-of-way. When washing is required, it shall be done on an area stabilized with aggregate, which drains into an approved sediment-trapping device. All sediment shall be prevented from entering storm drains, ditches, or watercourses.

Figure H – Construction Entrance Detail





**STANDARD AND SPECIFICATIONS  
FOR  
DUST CONTROL**



**6.3 Dust Control:**

During the construction phase of the project, approximately 4.50 acres of soil will be disturbed to facilitate land regrading and general building construction. The time interval from initial excavation of the proposed disturbed area to the seeding and mulching stabilization phase shall be kept to a minimum. During this window of time during construction of bare soil exposure, dust control may be necessary. Water shall be used as the preferred means of dust stabilization. Refer to the following specifications regarding dust control.

**Definition**

The control of dust resulting from land-disturbing activities.

**Purpose**

To prevent surface and air movement of dust from disturbed soil surfaces that may cause off-site damage, health hazards, and traffic safety problems.

**Conditions Where Practice Applies**

On construction roads, access points, and other disturbed areas subject to surface dust movement and dust blowing where off-site damage may occur if dust is not controlled.

**Design Criteria**

Construction operations should be scheduled to minimize the amount of area disturbed at one time. Buffer areas of vegetation should be left where practical. Temporary or permanent stabilization measures shall be installed. No specific design criteria are given; see construction specifications below for common methods of dust control. Water quality must be considered when materials are selected for dust control. Where there is a potential for

the material to wash off to a stream, ingredient information must be provided to the local permitting authority.

### **Construction Specifications**

#### **A.**

**Non-driving Areas** – These areas use products and materials applied or placed on soil surfaces to prevent airborne migration of soil particles.

**Vegetative Cover** – For disturbed areas not subject to traffic, vegetation provides the most practical method of dust control (see Section 3).

**Mulch** (including gravel mulch) – Mulch offers a fast effective means of controlling dust. This can also include rolled erosion control blankets.

**Spray adhesives** – These are products generally composed of polymers in a liquid or solid form that are mixed with water to form an emulsion that is sprayed on the soil surface with typical hydroseeding equipment. The mixing ratios and application rates will be in accordance with the manufacturer's recommendations for the specific soils on the site. In no case should the application of these adhesives be made on wet soils or if there is a probability of precipitation within 48 hours of its proposed use. Material Safety Data Sheets will be provided to all applicators and others working with the material.

#### **B.**

**Driving Areas** – These areas utilize water, polymer emulsions, and barriers to prevent dust movement from the traffic surface into the air.

**Sprinkling** – The site may be sprayed with water until the surface is wet. This is especially effective on haul roads and access routes.

**Polymer Additives** – These polymers are mixed with water and applied to the driving surface by a water truck with gravity feed drip bar, spray bar or automated distributor truck. The mixing ratios and application rates will be in accordance with the manufacturer's recommendations. Incorporation of the emulsion into the soil will be done to the appropriate depth based on expected traffic. Compaction after incorporation will be by vibratory roller to a minimum of 95%. The prepared surface shall be moist and no application of the polymer will be made if there is a probability of precipitation within 48 hours of its proposed use. Material Safety Data Sheets will be provided to all applicators working with the material.

**Barriers** – Woven geo-textiles can be placed on the driving surface to effectively reduce dust throw and particle migration on haul roads. Stone can also be used for construction roads for effective dust control.

**Windbreak** – A silt fence or similar barrier can control air currents at intervals equal to ten times the barrier height. Preserve existing wind barrier vegetation as much as practical.

August 2005 Page 5A.87 New York Standards and Specifications for Erosion and Sediment Control All Stormwater Pollution Prevention Plans must contain the NYS DEC issued "Conditions for Use" and "Application Instructions" for any polymers used on the site. This information can be obtained from the NYS DEC website.

### **Maintenance**



Maintain dust control measures through dry weather periods until all disturbed areas are stabilized.

## 7.0 Permanent Erosion & Sediment Control Measures

### **STANDARDS AND SPECIFICATIONS FOR LANDGRADING**



### 7.1 Landgrading:

#### **Definition**

Reshaping of the existing land surface in accordance with a plan as determined by engineering survey and layout.

#### **Purpose**

The purpose of a landgrading specification is to provide for erosion control and vegetative establishment on those areas where the existing land surface is to be reshaped by grading according to plan.

#### **Design Criteria**

The grading plan should be based upon the incorporation of building designs and street layouts that fit and utilize existing topography and desirable natural surrounding to avoid extreme grade modifications. Information submitted must provide sufficient topographic surveys and soil investigations to determine limitations that must be imposed on the grading operation related to slope stability, effect on adjacent properties and drainage patterns, measures for drainage and water removal and vegetative treatment, etc.

Many counties have regulations and design procedures already established for land grading and cut and fill slopes. Where these requirements exist, they shall be followed.

The plan must show existing and proposed contours of the area(s) to be graded. The plan shall also include practices for erosion control, slope stabilization, safe disposal of runoff water and drainage, such as waterways, lined ditches, reverse slope benches (include grade and cross section), grade stabilization structures, retaining walls, and surface and subsurface drains. The plan shall also include phasing of these practices. The following shall be incorporated into the plan:

1. Provisions shall be made to safely conduct surface runoff to storm drains, protected outlets, or to stable water courses to ensure that surface runoff will not damage slopes or other graded areas.
2. Cut and fill slopes that are to be stabilized with grasses shall not be steeper than 2:1. When slopes exceed 2:1, special design and stabilization considerations are required and shall be adequately shown on the plans. (Note: Where the slope is to be mowed, the slope should be no steeper than 3:1, although 4:1 is preferred because of safety factors related to mowing steep slopes.)
3. Reverse slope benches or diversions shall be provided whenever the vertical interval (height) of any 2:1 slope exceeds 20 feet; for 3:1 slope it shall be increased to 30 feet and for a 4:1 to 40 feet. Benches shall be located to divide the slope face as equally as possible and shall convey the water to a stable outlet. Soils, seeps, rock outcrops, etc., shall also be taken into consideration when designing benches.
  - A. Benches shall be a minimum of 6 feet wide to provide ease for maintenance.
  - B. Benches shall be designed with a reverse slope of 6:1 or flatter to the toe of the upper slope and with a minimum of one foot in depth. Bench gradient to the outlet shall be between 2 percent and 3 percent, unless accompanied by appropriate design and computations.
  - C. The flow length within a bench shall not exceed 800 feet unless accompanied by appropriate design and computations.
4. Surface water shall be diverted from the face of all cut and/or fill slopes by the use of diversions, ditches and swales or conveyed downslope by the use of a designed structure, except where:
  - A. The face of the slope is or shall be stabilized and the face of all graded slopes shall be protected from surface runoff until they are stabilized.
  - B. The face of the slope shall not be subject to any concentrated flows of surface water such as from natural drainage ways, graded swales, downspouts, etc.
  - C. The face of the slope will be protected by special erosion control materials, sod, gravel, riprap, or other stabilization method.
5. Cut slopes occurring in ripable rock shall be serrated. The serrations shall be made with conventional equipment as the excavation is made. Each step or serration shall be constructed on the contour and will have steps cut at nominal two-foot intervals with

nominal three-foot horizontal shelves. These steps will vary depending on the slope ratio or the cut slope. The nominal slope line is 1.5:1. These steps will weather and act to hold moisture, lime, fertilizer, and seed thus producing a much quicker and longer-lived vegetative cover and better slope stabilization. Overland flow shall be diverted from the top of all serrated cut slopes and carries to a suitable outlet.

6. Subsurface drainage shall be provided where necessary to intercept seepage that would otherwise adversely affect slope stability or create excessively wet site conditions.
7. Slopes shall not be created so close to property lines as to endanger adjoining properties without adequately protecting such properties against sedimentation, erosion, slippage, settlement, subsidence, or other related damages.
8. Fill material shall be free of brush, rubbish, rocks, logs, stumps, building debris, and other objectionable material. It should be free of stones over two inches in diameter where compacted by hand or mechanical tampers or over eight inches in diameter where compacted by rollers or other equipment. Frozen materials shall not be placed in the fill nor shall the fill material be placed on a frozen foundation.
9. Stockpiles, borrowed areas, and spoil shall be shown on the plans and shall be subject to the provision of this Standards and Specifications.
10. All disturbed areas shall be stabilized structurally or vegetatively in compliance with the Critical Area Treatment section of the New York State Standards and Specifications for Erosion and Sediment Control Manual.

### **Construction Specifications**

See Figure N below for the list of Construction Specifications. This list can also be found on the SWPPP details sheet included in the back of this report.

Figure I – Landgrading Detail

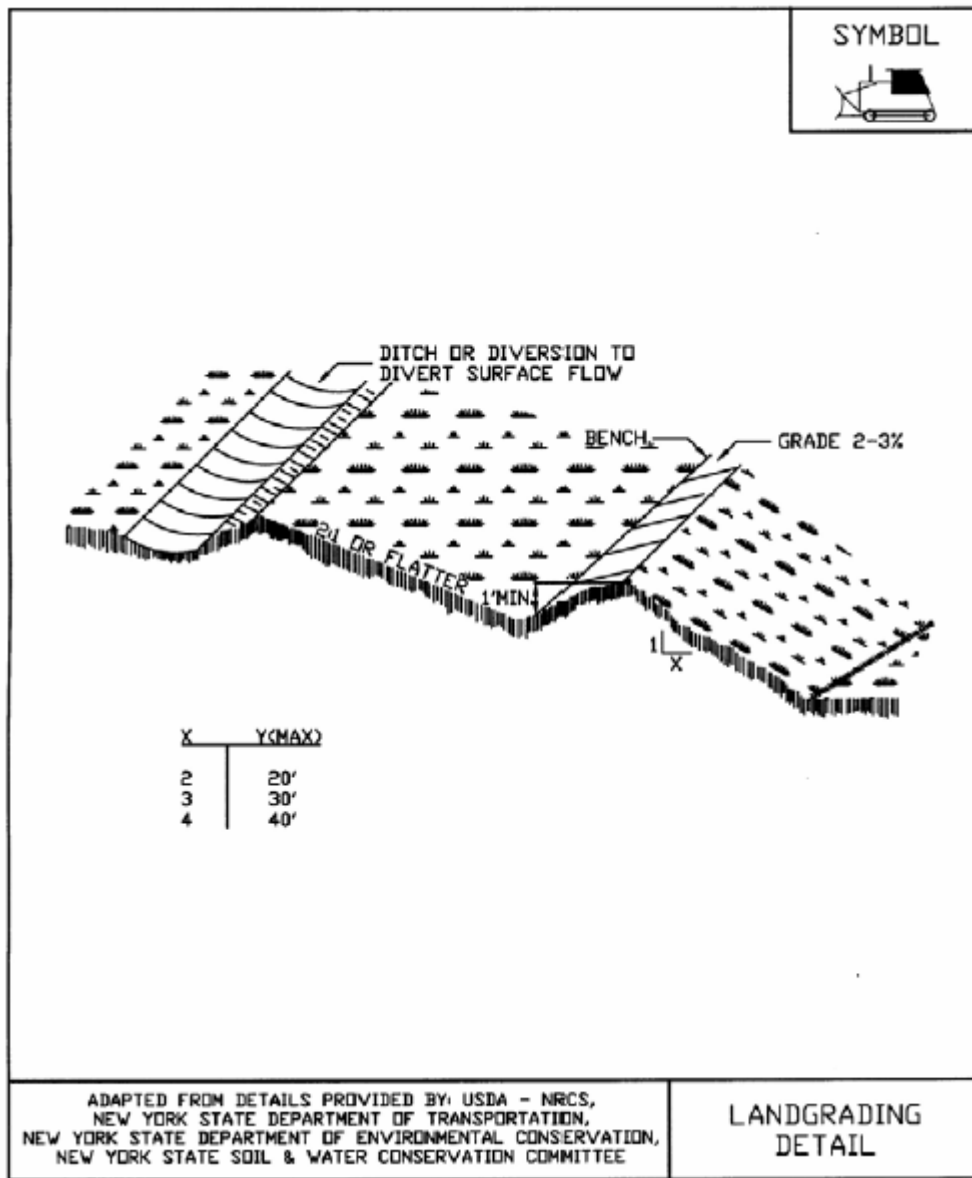




Figure J – Landgrading Construction Specifications Detail

<u>CONSTRUCTION SPECIFICATIONS</u>	
<ol style="list-style-type: none"> <li>1. ALL GRADED OR DISTURBED AREAS INCLUDING SLOPES SHALL BE PROTECTED DURING CLEARING AND CONSTRUCTION IN ACCORDANCE WITH THE APPROVED SEDIMENT CONTROL PLAN UNTIL THEY ARE PERMANENTLY STABILIZED.</li> <li>2. ALL SEDIMENT CONTROL PRACTICES AND MEASURES SHALL BE CONSTRUCTED, APPLIED AND MAINTAINED IN ACCORDANCE WITH THE APPROVED SEDIMENT CONTROL PLAN AND THE "STANDARDS AND SPECIFICATIONS FOR SOIL EROSION AND SEDIMENT CONTROL IN DEVELOPING AREAS".</li> <li>3. TOPSOIL REQUIRED FOR THE ESTABLISHMENT OF VEGETATION SHALL BE STOCKPILED IN AMOUNT NECESSARY TO COMPLETE FINISHED GRADING OF ALL EXPOSED AREAS.</li> <li>4. AREAS TO BE FILLED SHALL BE CLEARED, GRUBBED, AND STRIPPED OF TOPSOIL TO REMOVE TREES, VEGETATION, ROOTS OR OTHER OBJECTIONABLE MATERIAL.</li> <li>5. AREAS WHICH ARE TO BE TOPSOILED SHALL BE SCARIFIED TO A MINIMUM DEPTH OF FOUR INCHES PRIOR TO PLACEMENT OF TOPSOIL.</li> <li>6. ALL FILLS SHALL BE COMPACTED AS REQUIRED TO REDUCE EROSION, SLIPPAGE, SETTLEMENT, SUBSIDENCE OR OTHER RELATED PROBLEMS. FILL INTENDED TO SUPPORT BUILDINGS, STRUCTURES AND CONDUITS, ETC. SHALL BE COMPACTED IN ACCORDANCE WITH LOCAL REQUIREMENTS OR CODES.</li> <li>7. ALL FILL TO BE PLACED AND COMPACTED IN LAYERS NOT TO EXCEED 9 INCHES IN THICKNESS.</li> <li>8. EXCEPT FOR APPROVED LANDFILLS, FILL MATERIAL SHALL BE FREE OF FROZEN PARTICLES, BRUSH, ROOTS, SOD, OR OTHER FOREIGN OR OTHER OBJECTIONABLE MATERIALS THAT WOULD INTERFERE WITH OR PREVENT CONSTRUCTION OF SATISFACTORY FILLS.</li> <li>9. FROZEN MATERIALS OR SOFT, MUCKY OR HIGHLY COMPRESSIBLE MATERIALS SHALL NOT BE INCORPORATED IN FILLS.</li> <li>10. FILL SHALL NOT BE PLACED ON SATURATED OR FROZEN SURFACES.</li> <li>11. ALL BENCHES SHALL BE KEPT FREE OF SEDIMENT DURING ALL PHASES OF DEVELOPMENT.</li> <li>12. SEEPS OR SPRINGS ENCOUNTERED DURING CONSTRUCTION SHALL BE HANDLED IN ACCORDANCE WITH THE STANDARD AND SPECIFICATION FOR SUBSURFACE DRAIN OR OTHER APPROVED METHOD.</li> <li>13. ALL GRADED AREAS SHALL BE PERMANENTLY STABILIZED IMMEDIATELY FOLLOWING FINISHED GRADING.</li> <li>14. STOCKPILES, BORROW AREAS AND SPOIL AREAS SHALL BE SHOWN ON THE PLANS AND SHALL BE SUBJECT TO THE PROVISIONS OF THIS STANDARD AND SPECIFICATION.</li> </ol>	
<p>ADAPTED FROM DETAILS PROVIDED BY: USDA - NRCS, NEW YORK STATE DEPARTMENT OF TRANSPORTATION, NEW YORK STATE DEPARTMENT OF ENVIRONMENTAL CONSERVATION, NEW YORK STATE SOIL &amp; WATER CONSERVATION COMMITTEE</p>	<p><b>LANDGRADING SPECIFICATIONS</b></p>

## 8.0 Construction Schedule

As required under GP-0-15-002 permit coverage, a construction schedule for the site is required and must be strictly followed. This project is able to be done in a single phases and still to adhere to the NYS DEC policy of disturbing less than five (5) acres of land at any given time. Please refer to the construction schedule outlined below:

The construction sequence will be strictly followed unless a modified plan is submitted for review and approval by the Town.

### 8.1 Pre-Construction Schedule (Duplicate on SWPPP Plan Sheet)

#### PRE-CONSTRUCTION SEQUENCE:

1. Submit N.O.I. to bureau of water permits, Albany NY.
2. Receive acknowledgement back from NYSDEC.
3. Non-disturbance areas shall be marked with 4-ft orange snow fencing to town engineer's satisfaction prior to site disturbance, and shall be maintained until issuance of a Certificate-of-Occupancy.
4. Hold a pre-construction meeting with the site engineer, Town Engineer, contractor, erosion control inspector and building inspector. Place a copy of the SWPPP report on site along with a copy of the inspector's log book containing copies of the weekly inspections. (applicant's erosion & sediment control inspection agent shall conduct an inspection on a weekly basis)

### 8.2 Construction Schedule (Duplicate on SWPPP Plan Sheet)

#### CONSTRUCTION SEQUENCE:

1. Install and stabilize temporary erosion & sediment control measures as shown on the SWPPP plan.
2. Install temporary diversion swales as necessary to divert runoff away from construction.
3. Commence initial site clearing and grub remaining areas of disturbance.
4. Begin remaining site grading, driveway grade construction and foundation excavation.
5. Rough cut driveway and parking area to sub-grade
6. Pour concrete footings and foundations for proposed buildings.
7. Install drainage system.
8. Install remaining site utilities and/or infrastructure.
9. Install Stormtech systems as shown on the Utility Plan and as per Manufacturer's specifications.
10. Inspect Stormtech system for any sediment accumulation and/or damage before paving initial paving commences.

11. Pave driveway and install curbing once all major work on site is complete, as required.
12. Install on-pavement temporary inlet protection.
13. Topsoil, seed and mulch all disturbed areas that have obtained finished grade elevations.
14. Seed and mulch all disturbed areas that will not be re-disturbed for at least 14 days.
15. Finalize building construction.
16. Pave parking area and drives with final top-coat of asphalt
17. Once all major site disturbance activities have ceased and the site has achieved final stabilization, file an N.O.T. (notice of termination) with NYSDEC.
18. Terminate erosion control inspections.

### **8.3 Construction waste management plan**

Construction waste management practices are designed to maintain a clean and orderly work environment. This will reduce the potential for significant materials to come into contact with stormwater. A maintenance schedule shall be developed for these areas. The general contractor shall implement the following practices:

1. Material resulting from the clearing and grubbing operation will be stockpiled up slope from adequate sedimentation controls.
2. Equipment cleaning, maintenance, and repair areas shall be designated and protected by a temporary perimeter berm.
3. The use of detergents for large scale washing is prohibited (i.e., vehicles, buildings, pavement surfaces, etc.).
4. Spill Prevention and Response  
A Spill Prevention and Response Plan shall be developed for the site by the general contractor. The plan shall detail the steps needed to be followed in the event of an accidental spill and shall identify contact names and phone numbers of people and agencies that must be notified.

The plan shall include Material Safety Data Sheets (MSDS) for all materials to be stored on-site. All workers on-site will be required to be trained on safe handling and spill prevention procedures for all materials used during construction. Regular tailgate safety meetings shall be held and all workers that are expected on the site during the week shall be required to attend.

5. Material Storage  
Construction materials shall be stored in a dedicated staging area. The staging area shall be located in an area that minimizes the impacts of the construction materials effecting stormwater quality.

Chemicals, paints, solvents, fertilizers, and other toxic material must be stored in waterproof containers. Except during application, the contents must be kept in trucks or within storage facilities. Runoff containing such material must be collected, removed from the site, treated and disposed at an approved solid waste or chemical disposal facility.

6. Temporary Concrete Washout Facility

Temporary concrete washout facilities should be located a minimum of 50 ft from storm drain inlets, open drainage facilities, and watercourses. Each facility should be located away from construction traffic or access areas to prevent disturbance or tracking. A sign should be installed adjacent to each washout facility to inform concrete equipment operators to utilize the proper facilities.

When temporary concrete washout facilities are no longer required for the work, the hardened concrete shall be removed and disposed of. Materials used to construct the temporary concrete washout facilities shall be removed from the site and disposed of. Holes, depressions or other ground disturbance caused by the removal of the temporary concrete washout facilities shall be backfilled and/or repaired and seeded and mulched for final stabilization.

7. Solid Waste Disposal

No solid materials, including building materials, are allowed to be discharged from the site with stormwater. All solid waste, including disposable materials incidental to the major construction activities, must be collected and placed in containers. The containers will be emptied periodically by a contract trash disposal service and hauled away from the site.

Substances that have the potential for polluting surface and/or groundwater must be controlled by whatever means necessary in order to ensure that they do not discharge from the site. As an example, special care must be exercised during equipment fueling and servicing operations. If a spill occurs, it must be contained and disposed so that it will not flow from the site or enter groundwater, even if this requires removal, treatment, and disposal of soil. In this regard, potentially polluting substances should be handled in a manner consistent with the impact they represent.

8. Water Source

Non-stormwater components of site discharge must be clean water. Water used for construction, which discharges from the site, must originate from a public water supply or private well approved by the Health Department. Water used for construction that does not originate from an approved public supply must not discharge from the site. It can be retained in the ponds until it infiltrates and evaporates.

## 9.0 Conclusions

The SWPPP (Stormwater Pollution Prevention Plan) for the site for “935 Union Avenue.”, has been designed in accordance with New York State Department of Environmental Conservation (NYSDEC) technical standards as presented in the New York Standards and Specifications for Sediment and Erosion Control Manual (July 2016), and the New York State Stormwater Management Design Manual (August 2015). All BMP (Best Management Practices) have been applied to the site to ensure the proper control of any erosion and sediment created on site from disturbance activities. The Village of Suffern building inspector, Village Engineer and NYSDEC representative have the authority to modify, add or eliminate any erosion control practice on the construction site. The site’s owner shall file an NOI, included in Appendix F of this report, as required by the NYSDEC before starting construction.



## **Appendix**

---

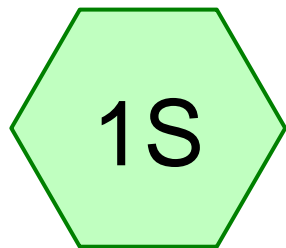




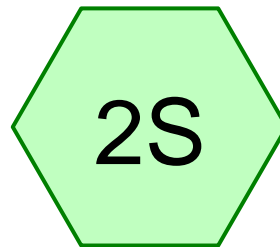
## Appendix A

# Pre-Development Cn, Tc Calculations & Pre-Development Hydrographs & Summary

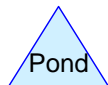
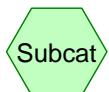




Pre Area 1



Pre Area 2



**2017.003 - Banta Hos**

Prepared by {enter your company name here}

HydroCAD® 10.00-18 s/n 04728 © 2016 HydroCAD Software Solutions LLC

Printed 4/17/2018

Page 2

**Area Listing (selected nodes)**

Area (acres)	CN	Description (subcatchment-numbers)
0.390	84	50-75% Grass cover, Fair, HSG D (1S, 2S)
0.016	98	Existing Sidewalk (1S)
0.151	98	Existing Building (1S)
1.187	98	Existing Pavement (1S)
1.365	82	Woods/grass comb., Fair, HSG D (1S, 2S)

**2017.003 - Banta Hos**

Prepared by {enter your company name here}

Printed 4/17/2018

HydroCAD® 10.00-18 s/n 04728 © 2016 HydroCAD Software Solutions LLC

Page 3

**Pipe Listing (selected nodes)**

Line#	Node Number	In-Invert (feet)	Out-Invert (feet)	Length (feet)	Slope (ft/ft)	n	Diam/Width (inches)	Height (inches)	Inside-Fill (inches)
1	1S	0.00	0.00	155.0	0.0225	0.012	12.0	0.0	0.0

**Summary for Subcatchment 1S: Pre Area 1**

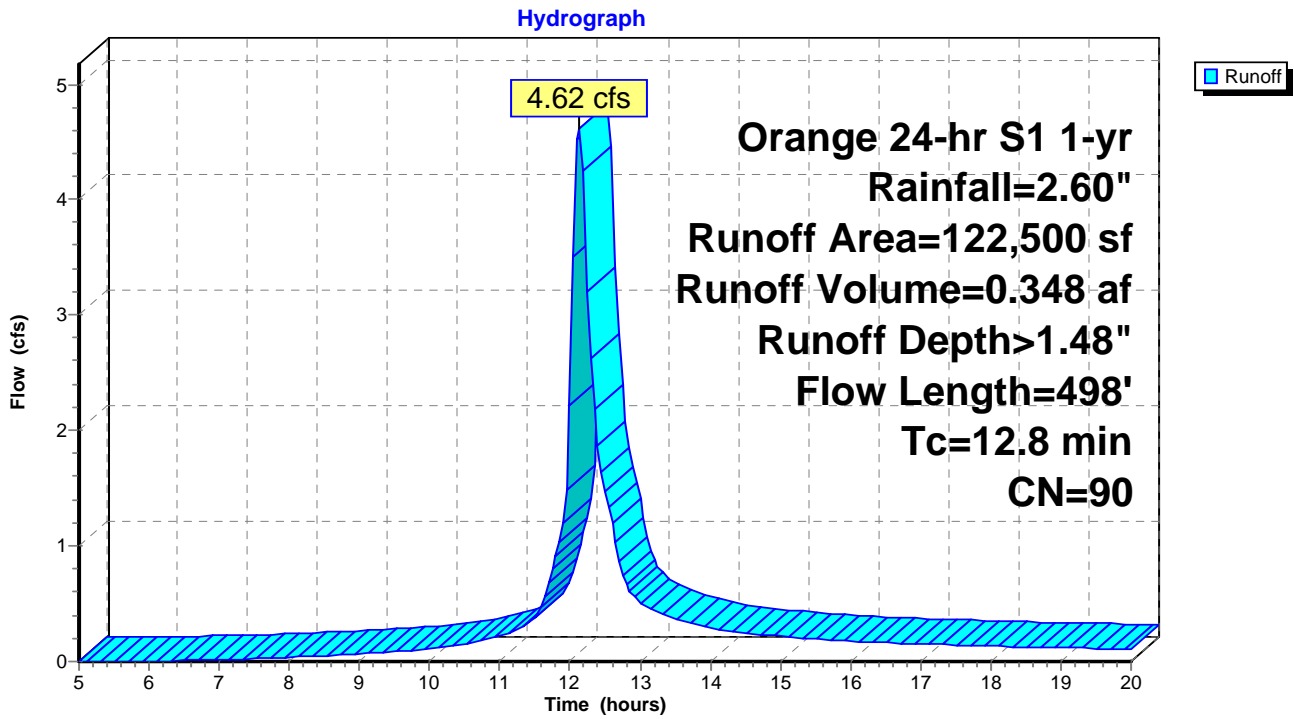
Runoff = 4.62 cfs @ 12.13 hrs, Volume= 0.348 af, Depth> 1.48"

Runoff by SCS TR-20 method, UH=SCS, Weighted-CN, Time Span= 5.00-20.00 hrs, dt= 0.05 hrs  
 Orange 24-hr S1 1-yr Rainfall=2.60"

Area (sf)	CN	Description
* 51,690	98	Existing Pavement
* 6,560	98	Existing Building
* 680	98	Existing Sidewalk
47,800	82	Woods/grass comb., Fair, HSG D
15,770	84	50-75% Grass cover, Fair, HSG D
122,500	90	Weighted Average
63,570		51.89% Pervious Area
58,930		48.11% Impervious Area

Tc (min)	Length (feet)	Slope (ft/ft)	Velocity (ft/sec)	Capacity (cfs)	Description
11.4	100	0.1100	0.15		<b>Sheet Flow, Reach A-B</b> Woods: Light underbrush n= 0.400 P2= 2.90"
0.1	15	0.3300	2.87		<b>Shallow Concentrated Flow, Reach B-C</b> Woodland Kv= 5.0 fps
0.0	12	0.3300	9.25		<b>Shallow Concentrated Flow, Reach C-D</b> Unpaved Kv= 16.1 fps
0.9	216	0.0350	3.80		<b>Shallow Concentrated Flow, Reach D-E</b> Paved Kv= 20.3 fps
0.4	155	0.0225	7.37	5.79	<b>Pipe Channel, Reach E-DP#1</b> 12.0" Round Area= 0.8 sf Perim= 3.1' r= 0.25' n= 0.012 Concrete pipe, finished
12.8	498	Total			

### Subcatchment 1S: Pre Area 1



**Summary for Subcatchment 2S: Pre Area 2**

Runoff = 0.34 cfs @ 12.11 hrs, Volume= 0.024 af, Depth> 0.96"

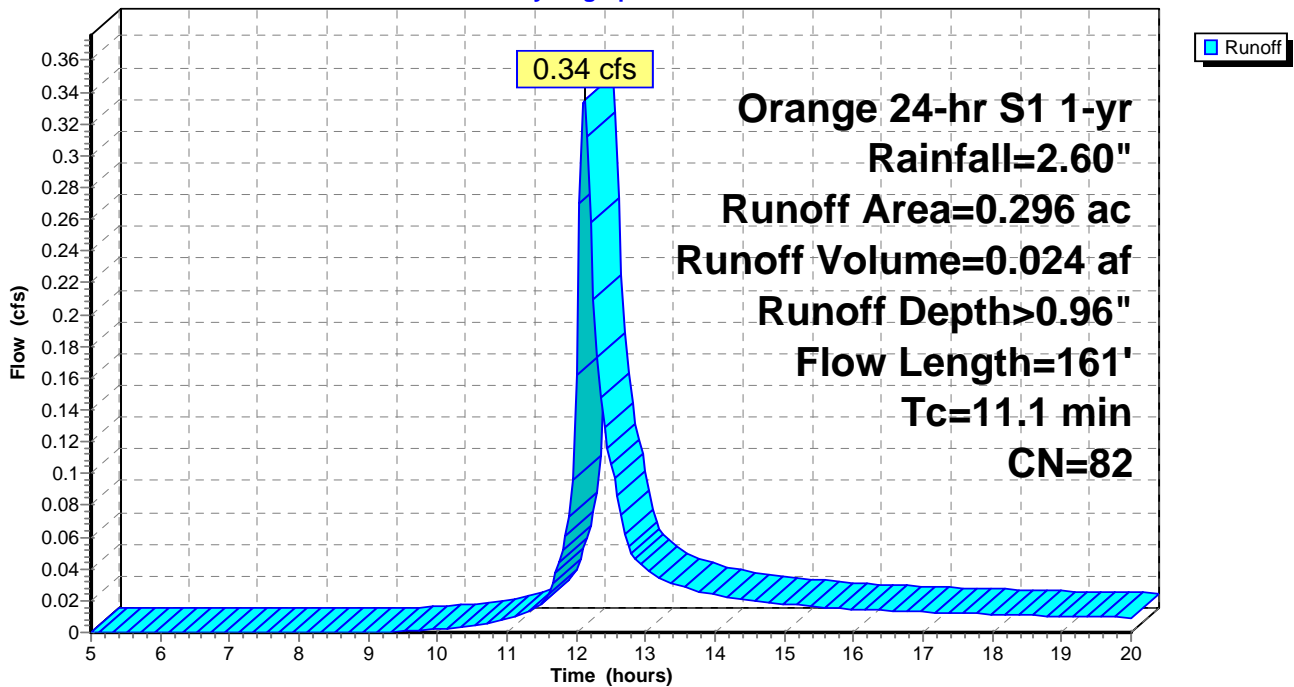
Runoff by SCS TR-20 method, UH=SCS, Weighted-CN, Time Span= 5.00-20.00 hrs, dt= 0.05 hrs  
 Orange 24-hr S1 1-yr Rainfall=2.60"

Area (ac)	CN	Description
0.268	82	Woods/grass comb., Fair, HSG D
0.028	84	50-75% Grass cover, Fair, HSG D
0.296	82	Weighted Average
0.296		100.00% Pervious Area

Tc (min)	Length (feet)	Slope (ft/ft)	Velocity (ft/sec)	Capacity (cfs)	Description
10.7	100	0.1300	0.16		<b>Sheet Flow, Reach A-B</b> Woods: Light underbrush n= 0.400 P2= 2.90"
0.2	30	0.1600	2.00		<b>Shallow Concentrated Flow, Reach B-C</b> Woodland Kv= 5.0 fps
0.1	31	0.1100	5.34		<b>Shallow Concentrated Flow, Reach C-DP#2</b> Unpaved Kv= 16.1 fps
11.1	161	Total			

**Subcatchment 2S: Pre Area 2**

Hydrograph





**Summary for Subcatchment 1S: Pre Area 1**

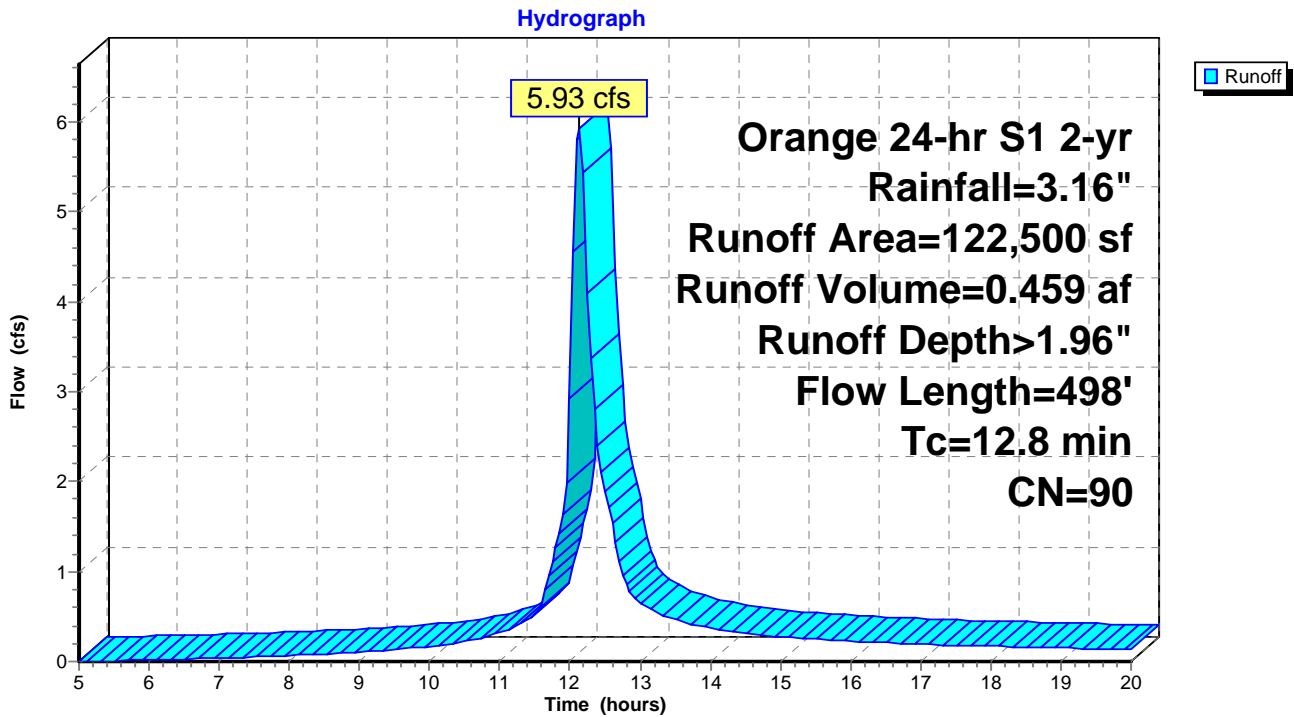
Runoff = 5.93 cfs @ 12.13 hrs, Volume= 0.459 af, Depth> 1.96"

Runoff by SCS TR-20 method, UH=SCS, Weighted-CN, Time Span= 5.00-20.00 hrs, dt= 0.05 hrs  
 Orange 24-hr S1 2-yr Rainfall=3.16"

Area (sf)	CN	Description
* 51,690	98	Exisitng Pavement
* 6,560	98	Exisitng Building
* 680	98	Exising Sidewalk
47,800	82	Woods/grass comb., Fair, HSG D
15,770	84	50-75% Grass cover, Fair, HSG D
122,500	90	Weighted Average
63,570		51.89% Pervious Area
58,930		48.11% Impervious Area

Tc (min)	Length (feet)	Slope (ft/ft)	Velocity (ft/sec)	Capacity (cfs)	Description
11.4	100	0.1100	0.15		<b>Sheet Flow, Reach A-B</b> Woods: Light underbrush n= 0.400 P2= 2.90"
0.1	15	0.3300	2.87		<b>Shallow Concentrated Flow, Reach B-C</b> Woodland Kv= 5.0 fps
0.0	12	0.3300	9.25		<b>Shallow Concentrated Flow, Reach C-D</b> Unpaved Kv= 16.1 fps
0.9	216	0.0350	3.80		<b>Shallow Concentrated Flow, Reach D-E</b> Paved Kv= 20.3 fps
0.4	155	0.0225	7.37	5.79	<b>Pipe Channel, Reach E-DP#1</b> 12.0" Round Area= 0.8 sf Perim= 3.1' r= 0.25' n= 0.012 Concrete pipe, finished
12.8	498	Total			

### Subcatchment 1S: Pre Area 1



**Summary for Subcatchment 2S: Pre Area 2**

Runoff = 0.47 cfs @ 12.11 hrs, Volume= 0.034 af, Depth> 1.36"

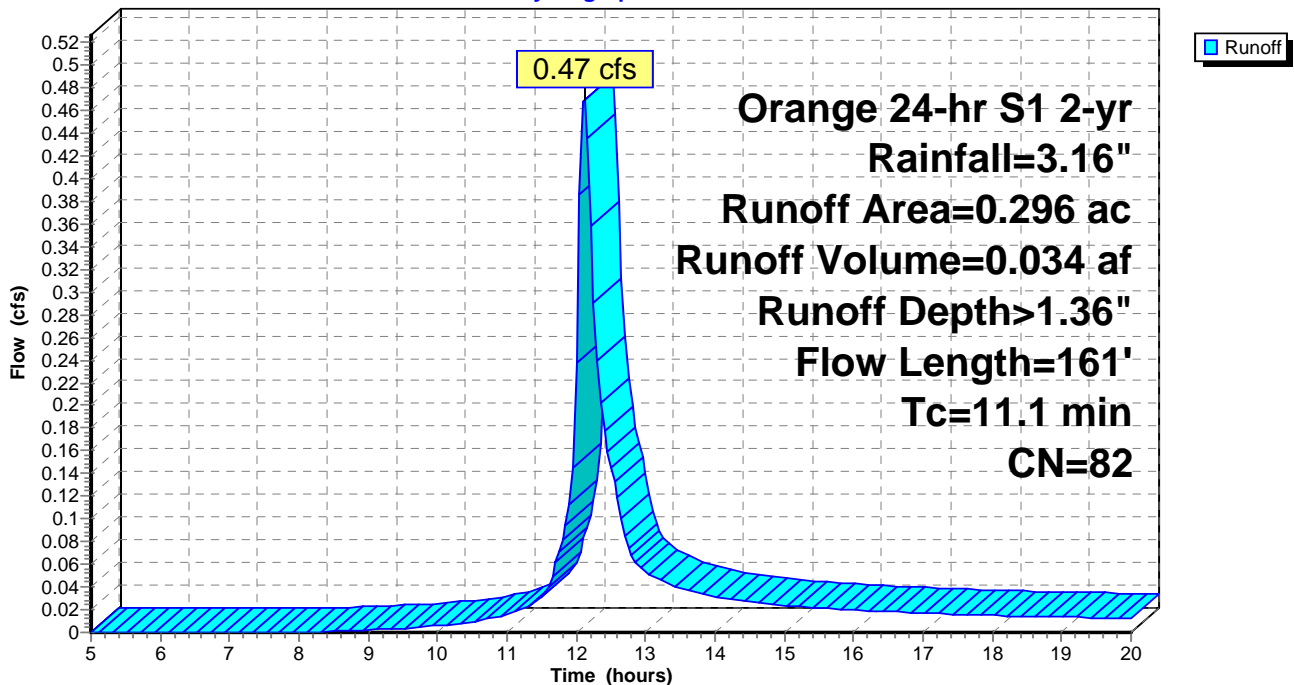
Runoff by SCS TR-20 method, UH=SCS, Weighted-CN, Time Span= 5.00-20.00 hrs, dt= 0.05 hrs  
 Orange 24-hr S1 2-yr Rainfall=3.16"

Area (ac)	CN	Description
0.268	82	Woods/grass comb., Fair, HSG D
0.028	84	50-75% Grass cover, Fair, HSG D
0.296	82	Weighted Average
0.296		100.00% Pervious Area

Tc (min)	Length (feet)	Slope (ft/ft)	Velocity (ft/sec)	Capacity (cfs)	Description
10.7	100	0.1300	0.16		<b>Sheet Flow, Reach A-B</b> Woods: Light underbrush n= 0.400 P2= 2.90"
0.2	30	0.1600	2.00		<b>Shallow Concentrated Flow, Reach B-C</b> Woodland Kv= 5.0 fps
0.1	31	0.1100	5.34		<b>Shallow Concentrated Flow, Reach C-DP#2</b> Unpaved Kv= 16.1 fps
11.1	161	Total			

**Subcatchment 2S: Pre Area 2**

Hydrograph



**Summary for Subcatchment 1S: Pre Area 1**

Runoff = 9.10 cfs @ 12.13 hrs, Volume= 0.776 af, Depth> 3.31"

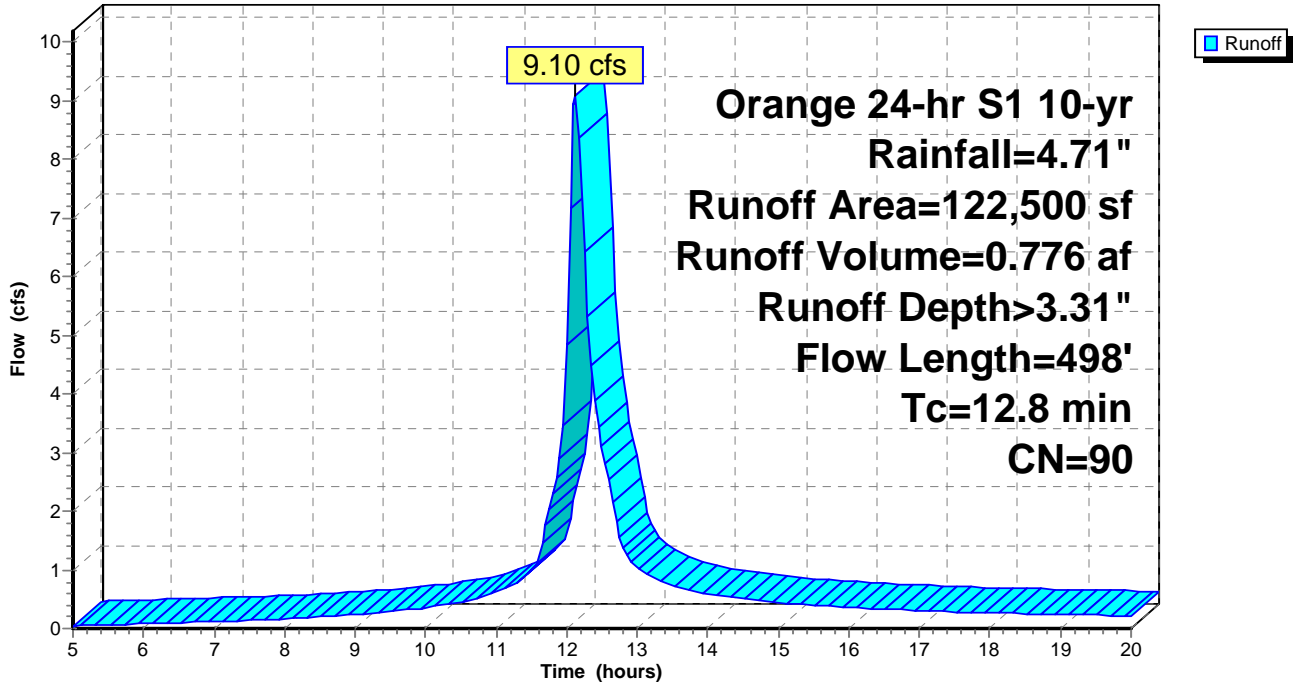
Runoff by SCS TR-20 method, UH=SCS, Weighted-CN, Time Span= 5.00-20.00 hrs, dt= 0.05 hrs  
 Orange 24-hr S1 10-yr Rainfall=4.71"

Area (sf)	CN	Description
* 51,690	98	Existing Pavement
* 6,560	98	Existing Building
* 680	98	Existing Sidewalk
47,800	82	Woods/grass comb., Fair, HSG D
15,770	84	50-75% Grass cover, Fair, HSG D
122,500	90	Weighted Average
63,570		51.89% Pervious Area
58,930		48.11% Impervious Area

Tc (min)	Length (feet)	Slope (ft/ft)	Velocity (ft/sec)	Capacity (cfs)	Description
11.4	100	0.1100	0.15		<b>Sheet Flow, Reach A-B</b> Woods: Light underbrush n= 0.400 P2= 2.90"
0.1	15	0.3300	2.87		<b>Shallow Concentrated Flow, Reach B-C</b> Woodland Kv= 5.0 fps
0.0	12	0.3300	9.25		<b>Shallow Concentrated Flow, Reach C-D</b> Unpaved Kv= 16.1 fps
0.9	216	0.0350	3.80		<b>Shallow Concentrated Flow, Reach D-E</b> Paved Kv= 20.3 fps
0.4	155	0.0225	7.37	5.79	<b>Pipe Channel, Reach E-DP#1</b> 12.0" Round Area= 0.8 sf Perim= 3.1' r= 0.25' n= 0.012 Concrete pipe, finished
12.8	498	Total			

Subcatchment 1S: Pre Area 1

Hydrograph



**Summary for Subcatchment 2S: Pre Area 2**

Runoff = 0.82 cfs @ 12.11 hrs, Volume= 0.063 af, Depth> 2.57"

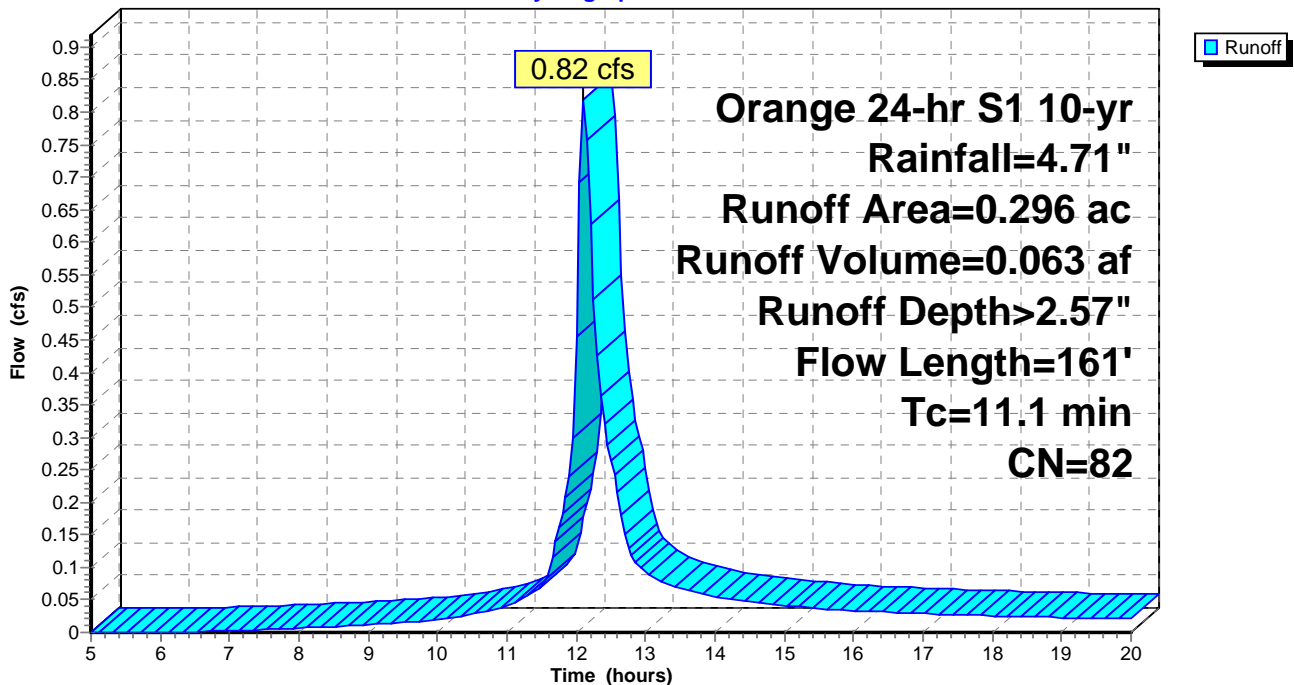
Runoff by SCS TR-20 method, UH=SCS, Weighted-CN, Time Span= 5.00-20.00 hrs, dt= 0.05 hrs  
 Orange 24-hr S1 10-yr Rainfall=4.71"

Area (ac)	CN	Description
0.268	82	Woods/grass comb., Fair, HSG D
0.028	84	50-75% Grass cover, Fair, HSG D
0.296	82	Weighted Average
0.296		100.00% Pervious Area

Tc (min)	Length (feet)	Slope (ft/ft)	Velocity (ft/sec)	Capacity (cfs)	Description
10.7	100	0.1300	0.16		<b>Sheet Flow, Reach A-B</b> Woods: Light underbrush n= 0.400 P2= 2.90"
0.2	30	0.1600	2.00		<b>Shallow Concentrated Flow, Reach B-C</b> Woodland Kv= 5.0 fps
0.1	31	0.1100	5.34		<b>Shallow Concentrated Flow, Reach C-DP#2</b> Unpaved Kv= 16.1 fps
11.1	161	Total			

**Subcatchment 2S: Pre Area 2**

Hydrograph



**Summary for Subcatchment 1S: Pre Area 1**

Runoff = 11.69 cfs @ 12.12 hrs, Volume= 1.027 af, Depth> 4.38"

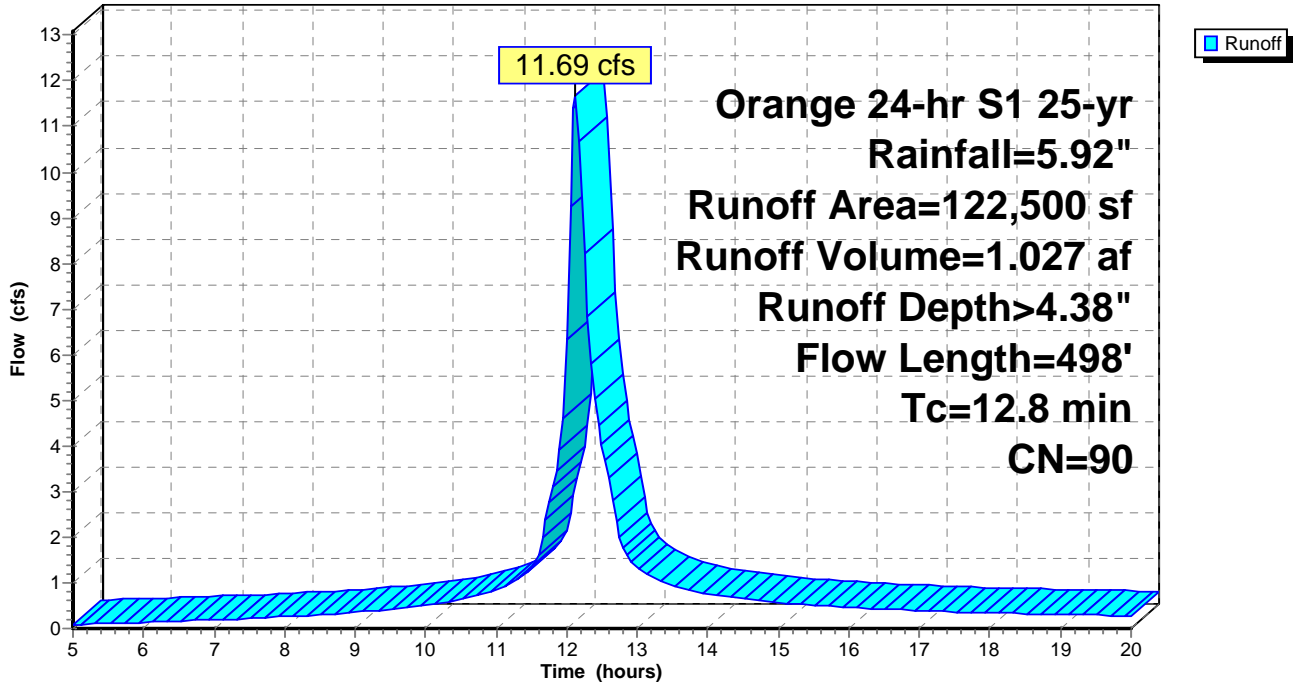
Runoff by SCS TR-20 method, UH=SCS, Weighted-CN, Time Span= 5.00-20.00 hrs, dt= 0.05 hrs  
 Orange 24-hr S1 25-yr Rainfall=5.92"

Area (sf)	CN	Description
* 51,690	98	Exisitng Pavement
* 6,560	98	Exisitng Building
* 680	98	Exising Sidewalk
47,800	82	Woods/grass comb., Fair, HSG D
15,770	84	50-75% Grass cover, Fair, HSG D
122,500	90	Weighted Average
63,570		51.89% Pervious Area
58,930		48.11% Impervious Area

Tc (min)	Length (feet)	Slope (ft/ft)	Velocity (ft/sec)	Capacity (cfs)	Description
11.4	100	0.1100	0.15		<b>Sheet Flow, Reach A-B</b> Woods: Light underbrush n= 0.400 P2= 2.90"
0.1	15	0.3300	2.87		<b>Shallow Concentrated Flow, Reach B-C</b> Woodland Kv= 5.0 fps
0.0	12	0.3300	9.25		<b>Shallow Concentrated Flow, Reach C-D</b> Unpaved Kv= 16.1 fps
0.9	216	0.0350	3.80		<b>Shallow Concentrated Flow, Reach D-E</b> Paved Kv= 20.3 fps
0.4	155	0.0225	7.37	5.79	<b>Pipe Channel, Reach E-DP#1</b> 12.0" Round Area= 0.8 sf Perim= 3.1' r= 0.25' n= 0.012 Concrete pipe, finished
12.8	498	Total			

### Subcatchment 1S: Pre Area 1

Hydrograph





**Summary for Subcatchment 2S: Pre Area 2**

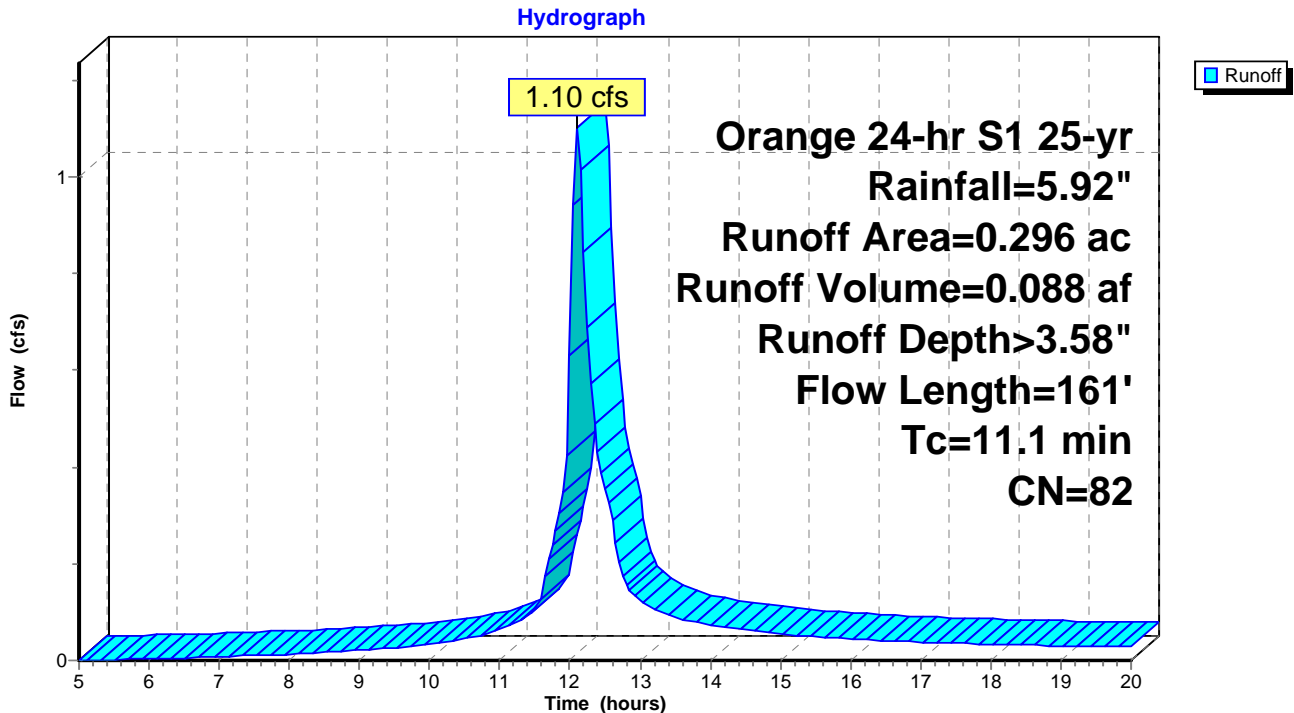
Runoff = 1.10 cfs @ 12.11 hrs, Volume= 0.088 af, Depth> 3.58"

Runoff by SCS TR-20 method, UH=SCS, Weighted-CN, Time Span= 5.00-20.00 hrs, dt= 0.05 hrs  
 Orange 24-hr S1 25-yr Rainfall=5.92"

Area (ac)	CN	Description
0.268	82	Woods/grass comb., Fair, HSG D
0.028	84	50-75% Grass cover, Fair, HSG D
0.296	82	Weighted Average
0.296		100.00% Pervious Area

Tc (min)	Length (feet)	Slope (ft/ft)	Velocity (ft/sec)	Capacity (cfs)	Description
10.7	100	0.1300	0.16		<b>Sheet Flow, Reach A-B</b> Woods: Light underbrush n= 0.400 P2= 2.90"
0.2	30	0.1600	2.00		<b>Shallow Concentrated Flow, Reach B-C</b> Woodland Kv= 5.0 fps
0.1	31	0.1100	5.34		<b>Shallow Concentrated Flow, Reach C-DP#2</b> Unpaved Kv= 16.1 fps
11.1	161	Total			

**Subcatchment 2S: Pre Area 2**



**Summary for Subcatchment 1S: Pre Area 1**

Runoff = 16.37 cfs @ 12.12 hrs, Volume= 1.539 af, Depth> 6.57"

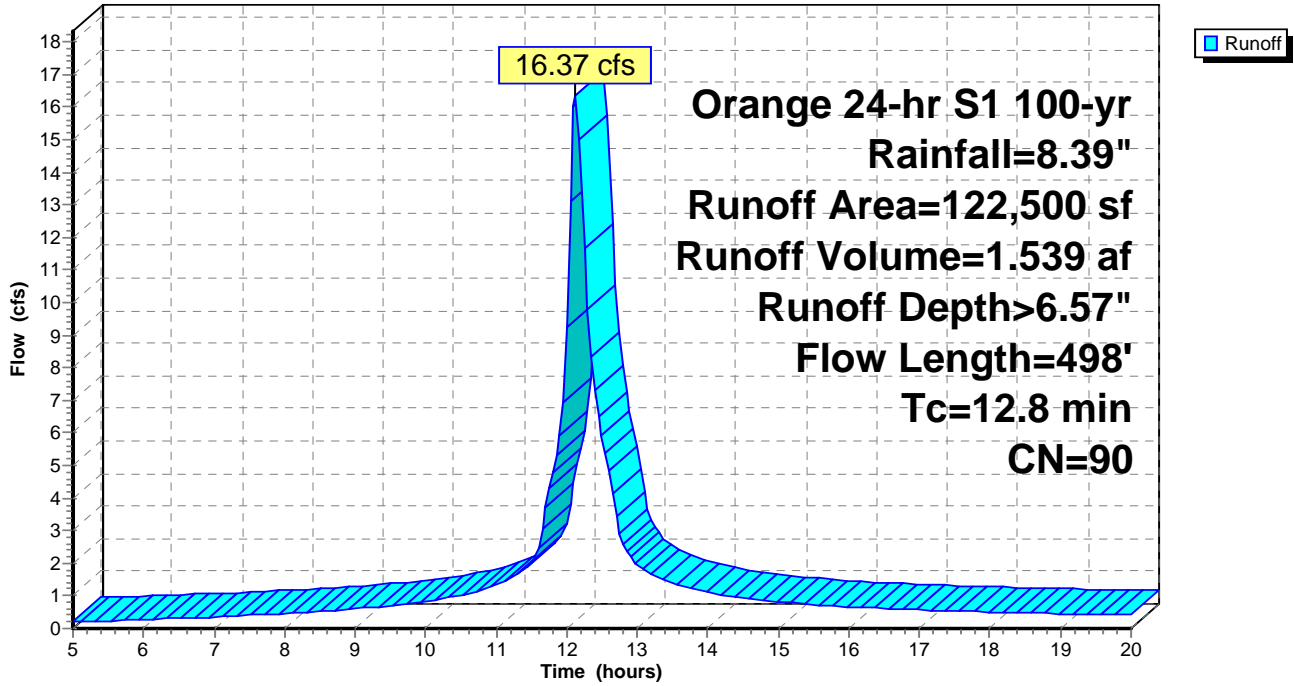
Runoff by SCS TR-20 method, UH=SCS, Weighted-CN, Time Span= 5.00-20.00 hrs, dt= 0.05 hrs  
 Orange 24-hr S1 100-yr Rainfall=8.39"

Area (sf)	CN	Description
* 51,690	98	Exisitng Pavement
* 6,560	98	Exisitng Building
* 680	98	Exising Sidewalk
47,800	82	Woods/grass comb., Fair, HSG D
15,770	84	50-75% Grass cover, Fair, HSG D
122,500	90	Weighted Average
63,570		51.89% Pervious Area
58,930		48.11% Impervious Area

Tc (min)	Length (feet)	Slope (ft/ft)	Velocity (ft/sec)	Capacity (cfs)	Description
11.4	100	0.1100	0.15		<b>Sheet Flow, Reach A-B</b> Woods: Light underbrush n= 0.400 P2= 2.90"
0.1	15	0.3300	2.87		<b>Shallow Concentrated Flow, Reach B-C</b> Woodland Kv= 5.0 fps
0.0	12	0.3300	9.25		<b>Shallow Concentrated Flow, Reach C-D</b> Unpaved Kv= 16.1 fps
0.9	216	0.0350	3.80		<b>Shallow Concentrated Flow, Reach D-E</b> Paved Kv= 20.3 fps
0.4	155	0.0225	7.37	5.79	<b>Pipe Channel, Reach E-DP#1</b> 12.0" Round Area= 0.8 sf Perim= 3.1' r= 0.25' n= 0.012 Concrete pipe, finished
12.8	498	Total			

### Subcatchment 1S: Pre Area 1

Hydrograph



**Summary for Subcatchment 2S: Pre Area 2**

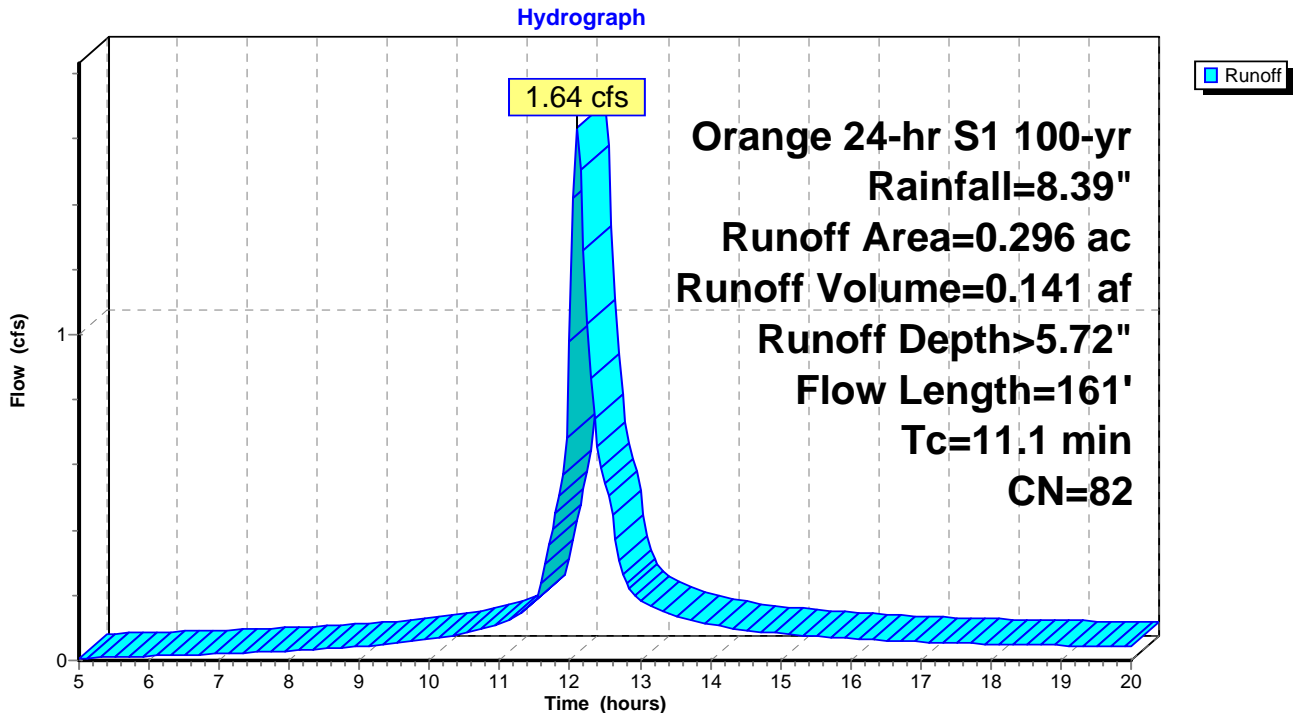
Runoff = 1.64 cfs @ 12.11 hrs, Volume= 0.141 af, Depth> 5.72"

Runoff by SCS TR-20 method, UH=SCS, Weighted-CN, Time Span= 5.00-20.00 hrs, dt= 0.05 hrs  
 Orange 24-hr S1 100-yr Rainfall=8.39"

Area (ac)	CN	Description
0.268	82	Woods/grass comb., Fair, HSG D
0.028	84	50-75% Grass cover, Fair, HSG D
0.296	82	Weighted Average
0.296		100.00% Pervious Area

Tc (min)	Length (feet)	Slope (ft/ft)	Velocity (ft/sec)	Capacity (cfs)	Description
10.7	100	0.1300	0.16		<b>Sheet Flow, Reach A-B</b> Woods: Light underbrush n= 0.400 P2= 2.90"
0.2	30	0.1600	2.00		<b>Shallow Concentrated Flow, Reach B-C</b> Woodland Kv= 5.0 fps
0.1	31	0.1100	5.34		<b>Shallow Concentrated Flow, Reach C-DP#2</b> Unpaved Kv= 16.1 fps
11.1	161	Total			

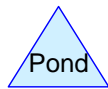
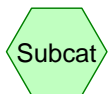
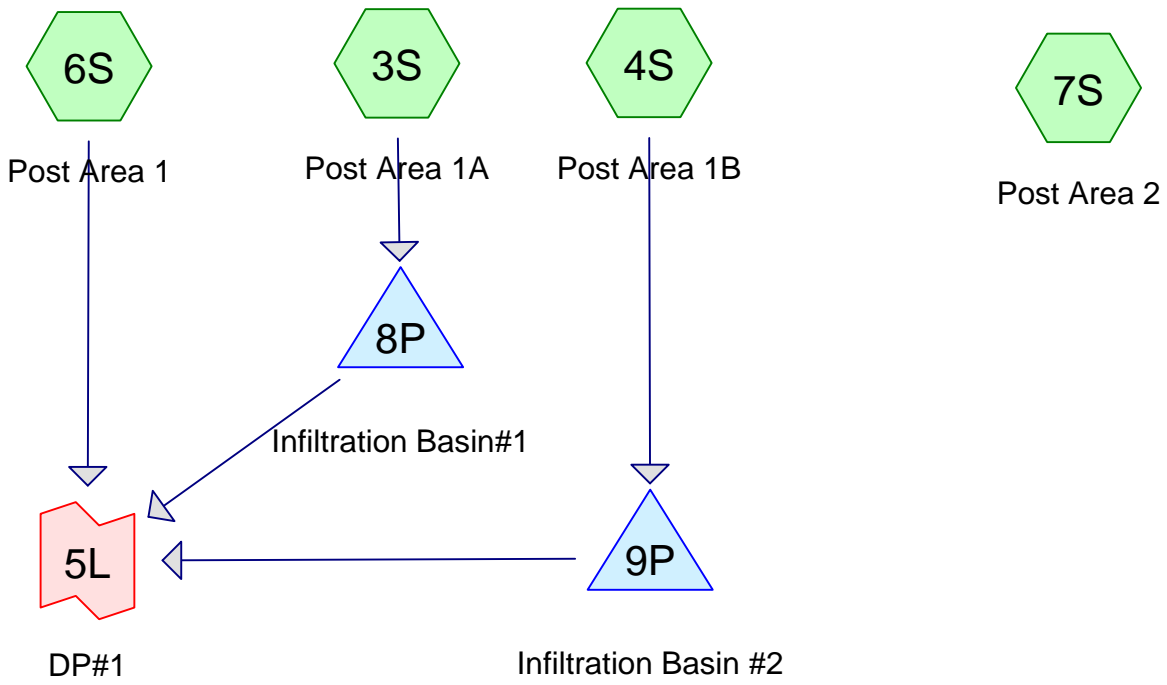
**Subcatchment 2S: Pre Area 2**



## Appendix B

# Post-Development Cn, Tc Calculations & Post-Development Hydrographs & Summary





**Routing Diagram for 2017.003 - Banta Hos**  
 Prepared by {enter your company name here}, Printed 4/17/2018  
 HydroCAD® 10.00-18 s/n 04728 © 2016 HydroCAD Software Solutions LLC

## 2017.003 - Banta Hos

Prepared by {enter your company name here}

HydroCAD® 10.00-18 s/n 04728 © 2016 HydroCAD Software Solutions LLC

Printed 4/17/2018

Page 2

### Area Listing (selected nodes)

Area (acres)	CN	Description (subcatchment-numbers)
1.043	80	>75% Grass cover, Good, HSG D (3S, 4S, 6S, 7S)
0.315	98	Proposed Building (3S, 4S)
1.132	98	Proposed Pavement (3S, 4S, 6S)
0.055	98	Proposed Sidewalk (3S, 4S)
0.685	82	Woods/grass comb., Fair, HSG D (3S, 4S)
<b>3.230</b>	<b>89</b>	<b>TOTAL AREA</b>



**2017.003 - Banta Hos**

Prepared by {enter your company name here}

Printed 4/17/2018

HydroCAD® 10.00-18 s/n 04728 © 2016 HydroCAD Software Solutions LLC

Page 3

**Pipe Listing (selected nodes)**

Line#	Node Number	In-Invert (feet)	Out-Invert (feet)	Length (feet)	Slope (ft/ft)	n	Diam/Width (inches)	Height (inches)	Inside-Fill (inches)
1	3S	0.00	0.00	185.0	0.0190	0.013	18.0	0.0	0.0
2	4S	0.00	0.00	54.0	0.0090	0.013	18.0	0.0	0.0
3	6S	0.00	0.00	155.0	0.0004	0.012	12.0	0.0	0.0
4	8P	328.10	326.90	30.0	0.0400	0.013	18.0	0.0	0.0
5	9P	328.10	326.90	30.0	0.0400	0.013	18.0	0.0	0.0

**Summary for Subcatchment 3S: Post Area 1A**

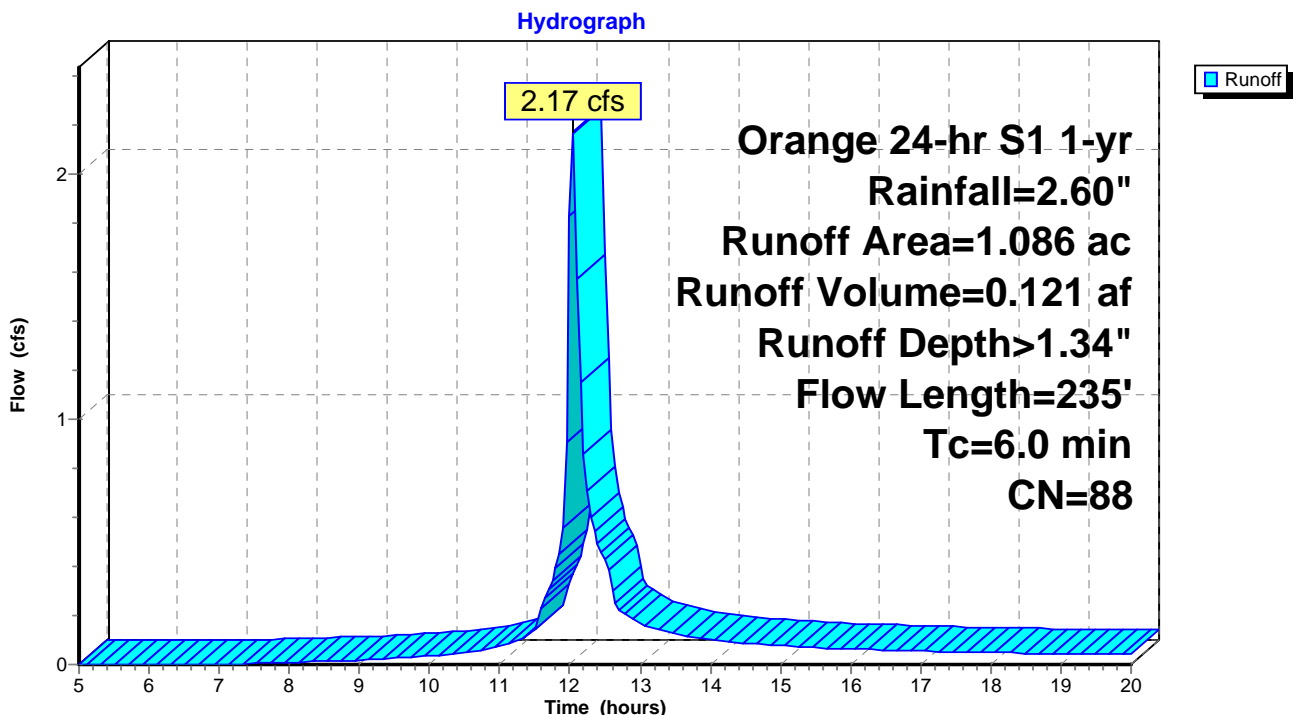
Runoff = 2.17 cfs @ 12.04 hrs, Volume= 0.121 af, Depth> 1.34"

Runoff by SCS TR-20 method, UH=SCS, Weighted-CN, Time Span= 5.00-20.00 hrs, dt= 0.05 hrs  
 Orange 24-hr S1 1-yr Rainfall=2.60"

Area (ac)	CN	Description
* 0.302	98	Proposed Pavement
* 0.107	98	Proposed Building
* 0.024	98	Proposed Sidewalk
0.236	80	>75% Grass cover, Good, HSG D
0.417	82	Woods/grass comb., Fair, HSG D
1.086	88	Weighted Average
0.653		60.13% Pervious Area
0.433		39.87% Impervious Area

Tc (min)	Length (feet)	Slope (ft/ft)	Velocity (ft/sec)	Capacity (cfs)	Description
0.6	50	0.0400	1.50		<b>Sheet Flow, Reach A-B</b> Smooth surfaces n= 0.011 P2= 2.90"
0.4	185	0.0190	8.19	14.48	<b>Pipe Channel, Rach B-C</b> 18.0" Round Area= 1.8 sf Perim= 4.7' r= 0.38' n= 0.013 Corrugated PE, smooth interior
5.0					<b>Direct Entry,</b>
6.0	235	Total			

**Subcatchment 3S: Post Area 1A**



**Summary for Subcatchment 4S: Post Area 1B**

Runoff = 4.10 cfs @ 12.04 hrs, Volume= 0.232 af, Depth> 1.57"

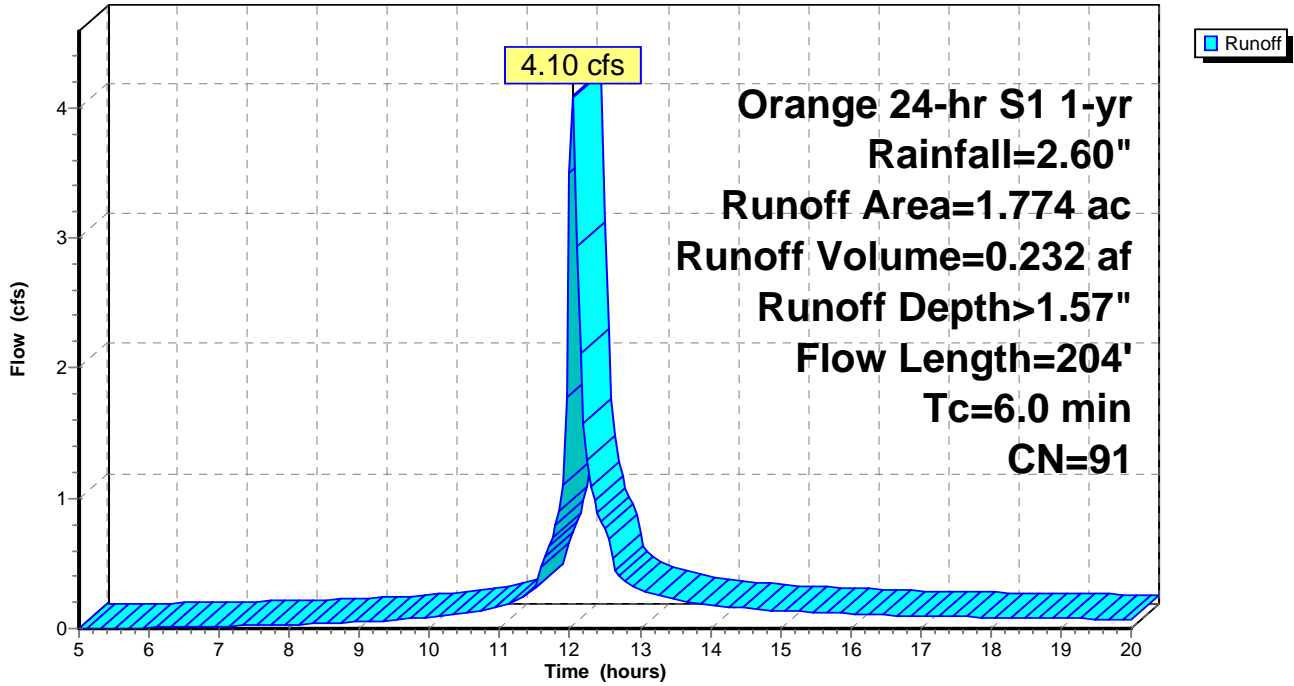
Runoff by SCS TR-20 method, UH=SCS, Weighted-CN, Time Span= 5.00-20.00 hrs, dt= 0.05 hrs  
 Orange 24-hr S1 1-yr Rainfall=2.60"

Area (ac)	CN	Description
* 0.798	98	Proposed Pavement
* 0.208	98	Proposed Building
* 0.031	98	Proposed Sidewalk
0.469	80	>75% Grass cover, Good, HSG D
0.268	82	Woods/grass comb., Fair, HSG D
1.774	91	Weighted Average
0.737		41.54% Pervious Area
1.037		58.46% Impervious Area

Tc (min)	Length (feet)	Slope (ft/ft)	Velocity (ft/sec)	Capacity (cfs)	Description
2.1	10	0.0800	0.08		<b>Sheet Flow, Reach A-B</b> Woods: Light underbrush n= 0.400 P2= 2.90"
0.1	30	0.3300	9.25		<b>Shallow Concentrated Flow, Reach B-C</b> Unpaved Kv= 16.1 fps
0.4	110	0.0500	4.54		<b>Shallow Concentrated Flow, Reach C-D</b> Paved Kv= 20.3 fps
0.2	54	0.0090	5.64	9.97	<b>Pipe Channel, Reach D-E</b> 18.0" Round Area= 1.8 sf Perim= 4.7' r= 0.38' n= 0.013 Corrugated PE, smooth interior
3.2					<b>Direct Entry,</b>
6.0	204	Total			

Subcatchment 4S: Post Area 1B

Hydrograph



**Summary for Subcatchment 6S: Post Area 1**

Runoff = 0.38 cfs @ 12.10 hrs, Volume= 0.026 af, Depth> 0.96"

Runoff by SCS TR-20 method, UH=SCS, Weighted-CN, Time Span= 5.00-20.00 hrs, dt= 0.05 hrs  
 Orange 24-hr S1 1-yr Rainfall=2.60"

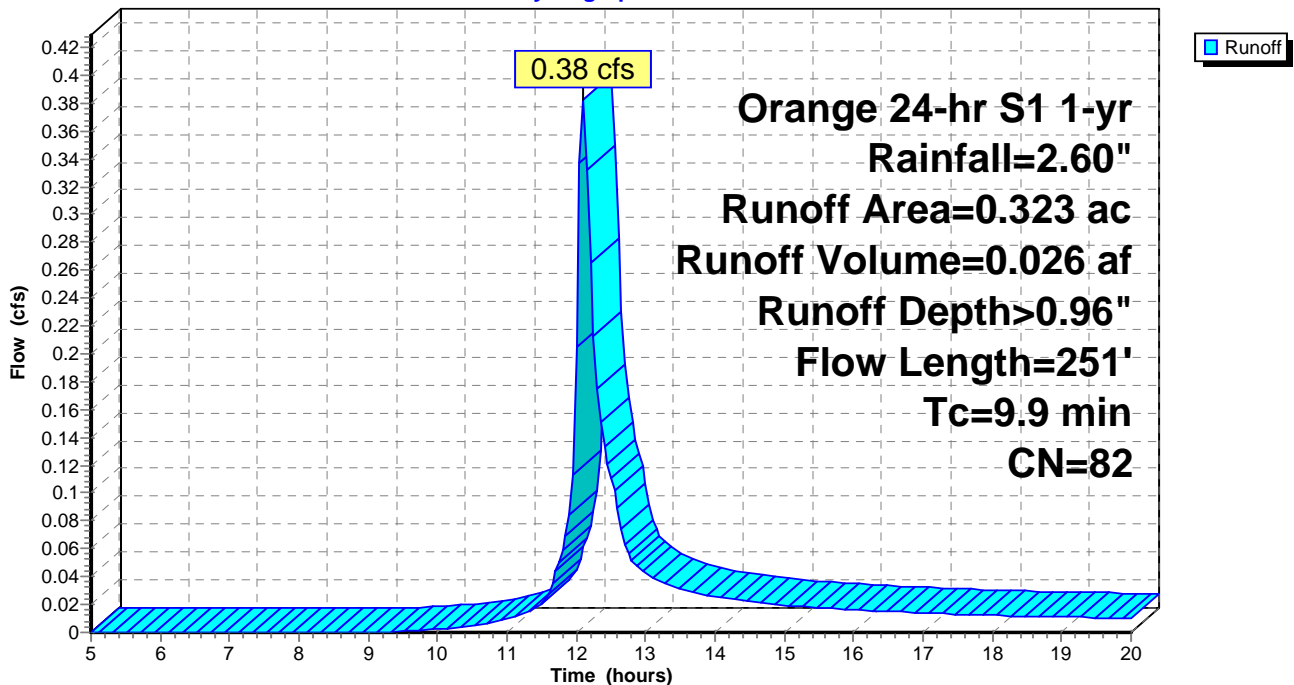
Area (ac)	CN	Description
0.291	80	>75% Grass cover, Good, HSG D
* 0.032	98	Proposed Pavement
0.323	82	Weighted Average
0.291		90.09% Pervious Area
0.032		9.91% Impervious Area

Tc (min)	Length (feet)	Slope (ft/ft)	Velocity (ft/sec)	Capacity (cfs)	Description
7.3	96	0.0430	0.22		<b>Sheet Flow, Reach A-B</b> Grass: Short n= 0.150 P2= 2.90"
2.6	155	0.0004	0.98	0.77	<b>Pipe Channel, RCP_Round 12"</b> 12.0" Round Area= 0.8 sf Perim= 3.1' r= 0.25' n= 0.012 Concrete pipe, finished
9.9	251	Total			

**Subcatchment 6S: Post Area 1**

Hydrograph



**Summary for Subcatchment 7S: Post Area 2**

Runoff = 0.06 cfs @ 12.05 hrs, Volume= 0.003 af, Depth> 0.86"

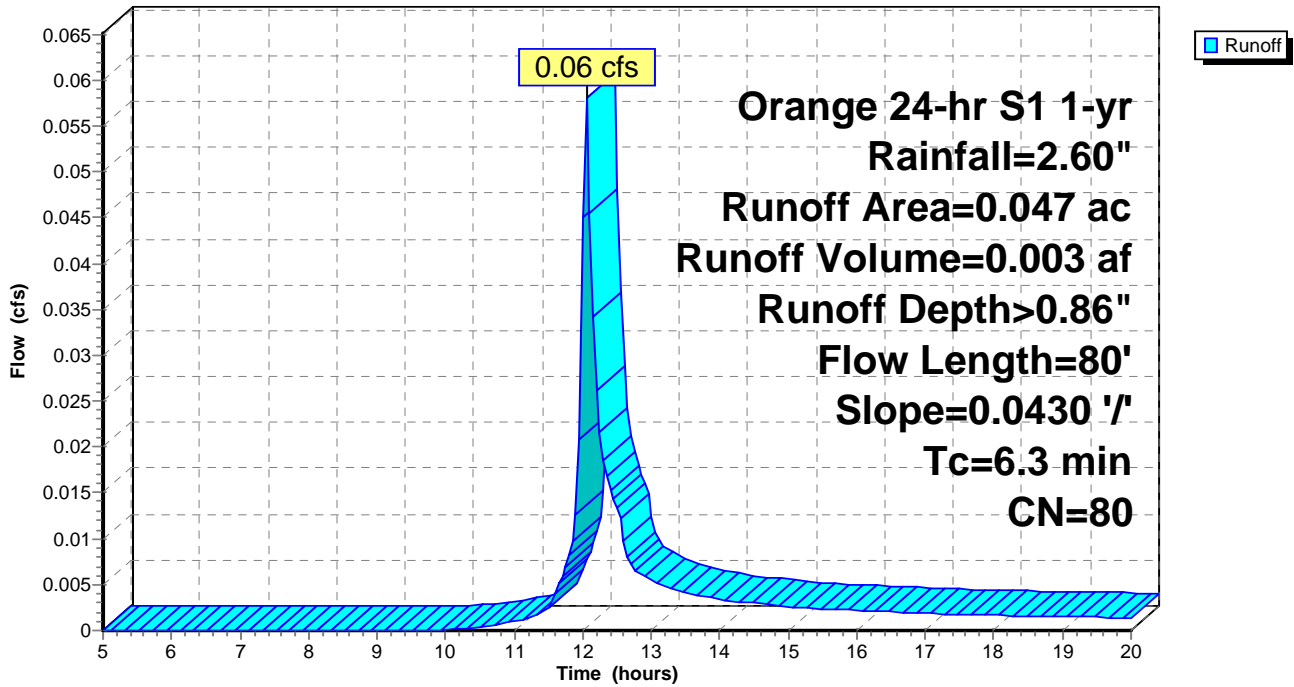
Runoff by SCS TR-20 method, UH=SCS, Weighted-CN, Time Span= 5.00-20.00 hrs, dt= 0.05 hrs  
 Orange 24-hr S1 1-yr Rainfall=2.60"

Area (ac)	CN	Description
0.047	80	>75% Grass cover, Good, HSG D
0.047		100.00% Pervious Area

Tc (min)	Length (feet)	Slope (ft/ft)	Velocity (ft/sec)	Capacity (cfs)	Description
6.3	80	0.0430	0.21		Sheet Flow, Reach A-B Grass: Short n= 0.150 P2= 2.90"

**Subcatchment 7S: Post Area 2**

Hydrograph



**Summary for Pond 8P: Infiltration Basin#1**

Inflow Area = 1.086 ac, 39.87% Impervious, Inflow Depth > 1.34" for 1-yr event  
 Inflow = 2.17 cfs @ 12.04 hrs, Volume= 0.121 af  
 Outflow = 0.87 cfs @ 12.00 hrs, Volume= 0.121 af, Atten= 60%, Lag= 0.0 min  
 Discarded = 0.87 cfs @ 12.00 hrs, Volume= 0.121 af  
 Primary = 0.00 cfs @ 5.00 hrs, Volume= 0.000 af

Routing by Stor-Ind method, Time Span= 5.00-20.00 hrs, dt= 0.05 hrs  
 Peak Elev= 330.83' @ 12.21 hrs Surf.Area= 2,500 sf Storage= 629 cf

Plug-Flow detention time= (not calculated: outflow precedes inflow)  
 Center-of-Mass det. time= 3.4 min ( 793.5 - 790.1 )

Volume	Invert	Avail.Storage	Storage Description
#1	330.20'	3,248 cf	<b>Custom Stage Data (Prismatic)</b> Listed below (Recalc) 10,050 cf Overall - 1,929 cf Embedded = 8,121 cf x 40.0% Voids
#2	331.22'	1,929 cf	<b>ADS StormTech SC-740 +Cap</b> x 42 Inside #1 Effective Size= 44.6"W x 30.0"H => 6.45 sf x 7.12'L = 45.9 cf Overall Size= 51.0"W x 30.0"H x 7.56'L with 0.44' Overlap 6 Rows of 7 Chambers
		5,178 cf	Total Available Storage

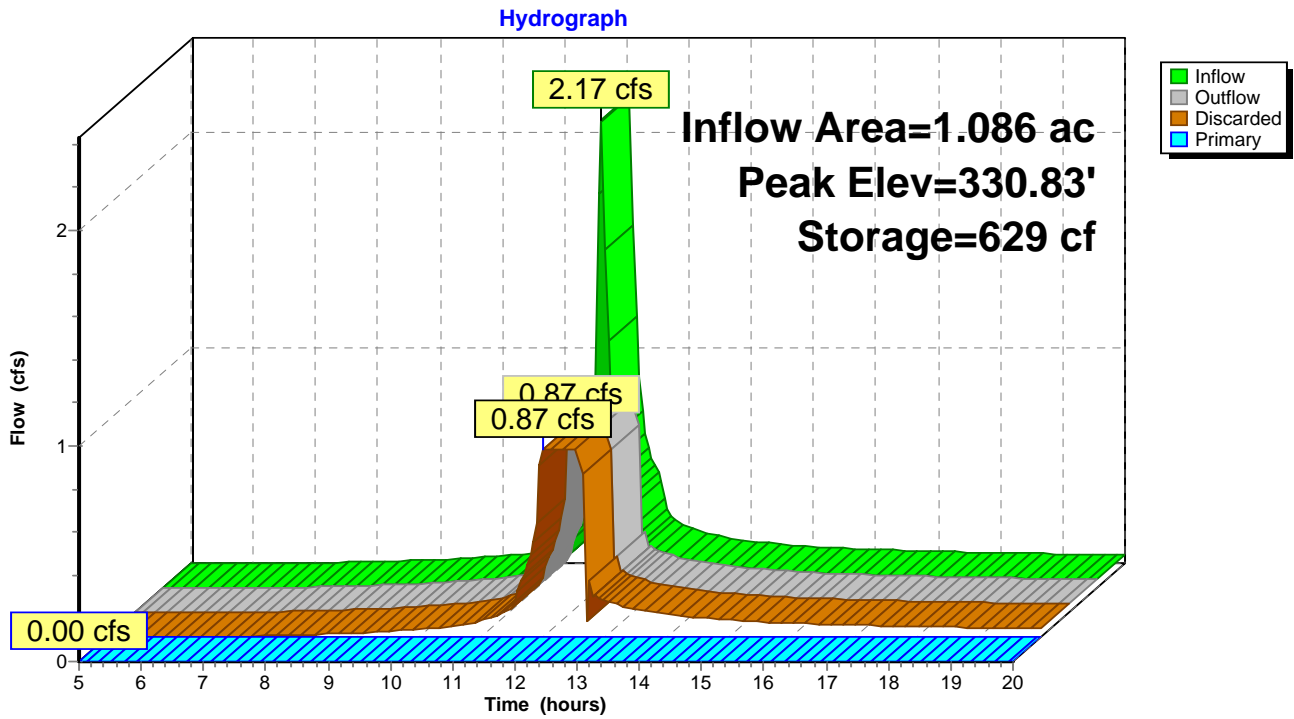
Elevation (feet)	Surf.Area (sq-ft)	Inc.Store (cubic-feet)	Cum.Store (cubic-feet)
330.20	2,500	0	0
334.22	2,500	10,050	10,050

Device	Routing	Invert	Outlet Devices
#1	Primary	328.10'	<b>18.0" Round Culvert</b> L= 30.0' CMP, square edge headwall, Ke= 0.500 Inlet / Outlet Invert= 328.10' / 326.90' S= 0.0400 '/' Cc= 0.900 n= 0.013 Corrugated PE, smooth interior, Flow Area= 1.77 sf
#2	Device 1	333.75'	<b>4.0' long Sharp-Crested Vee/Trap Weir</b> Cv= 2.62 (C= 3.28)
#3	Discarded	330.20'	<b>15.000 in/hr Exfiltration over Surface area</b>

**Discarded OutFlow** Max=0.87 cfs @ 12.00 hrs HW=330.33' (Free Discharge)  
 ↳ **3=Exfiltration** (Exfiltration Controls 0.87 cfs)

**Primary OutFlow** Max=0.00 cfs @ 5.00 hrs HW=330.20' (Free Discharge)  
 ↳ **1=Culvert** (Passes 0.00 cfs of 9.89 cfs potential flow)  
 ↳ **2=Sharp-Crested Vee/Trap Weir** ( Controls 0.00 cfs)

### Pond 8P: Infiltration Basin#1





**Summary for Pond 9P: Infiltration Basin #2**

Inflow Area = 1.774 ac, 58.46% Impervious, Inflow Depth > 1.57" for 1-yr event  
 Inflow = 4.10 cfs @ 12.04 hrs, Volume= 0.232 af  
 Outflow = 0.84 cfs @ 11.85 hrs, Volume= 0.231 af, Atten= 79%, Lag= 0.0 min  
 Discarded = 0.84 cfs @ 11.85 hrs, Volume= 0.231 af  
 Primary = 0.00 cfs @ 5.00 hrs, Volume= 0.000 af

Routing by Stor-Ind method, Time Span= 5.00-20.00 hrs, dt= 0.05 hrs  
 Peak Elev= 332.90' @ 12.44 hrs Surf.Area= 2,427 sf Storage= 2,218 cf

Plug-Flow detention time= 14.9 min calculated for 0.231 af (100% of inflow)  
 Center-of-Mass det. time= 14.7 min ( 792.0 - 777.3 )

Volume	Invert	Avail.Storage	Storage Description
#1	331.00'	3,266 cf	<b>Custom Stage Data (Prismatic)</b> Listed below (Recalc) 10,922 cf Overall - 2,756 cf Embedded = 8,165 cf x 40.0% Voids
#2	332.50'	2,756 cf	<b>ADS StormTech SC-740 +Cap</b> x 60 Inside #1 Effective Size= 44.6"W x 30.0"H => 6.45 sf x 7.12'L = 45.9 cf Overall Size= 51.0"W x 30.0"H x 7.56'L with 0.44' Overlap 6 Rows of 10 Chambers
		6,022 cf	Total Available Storage

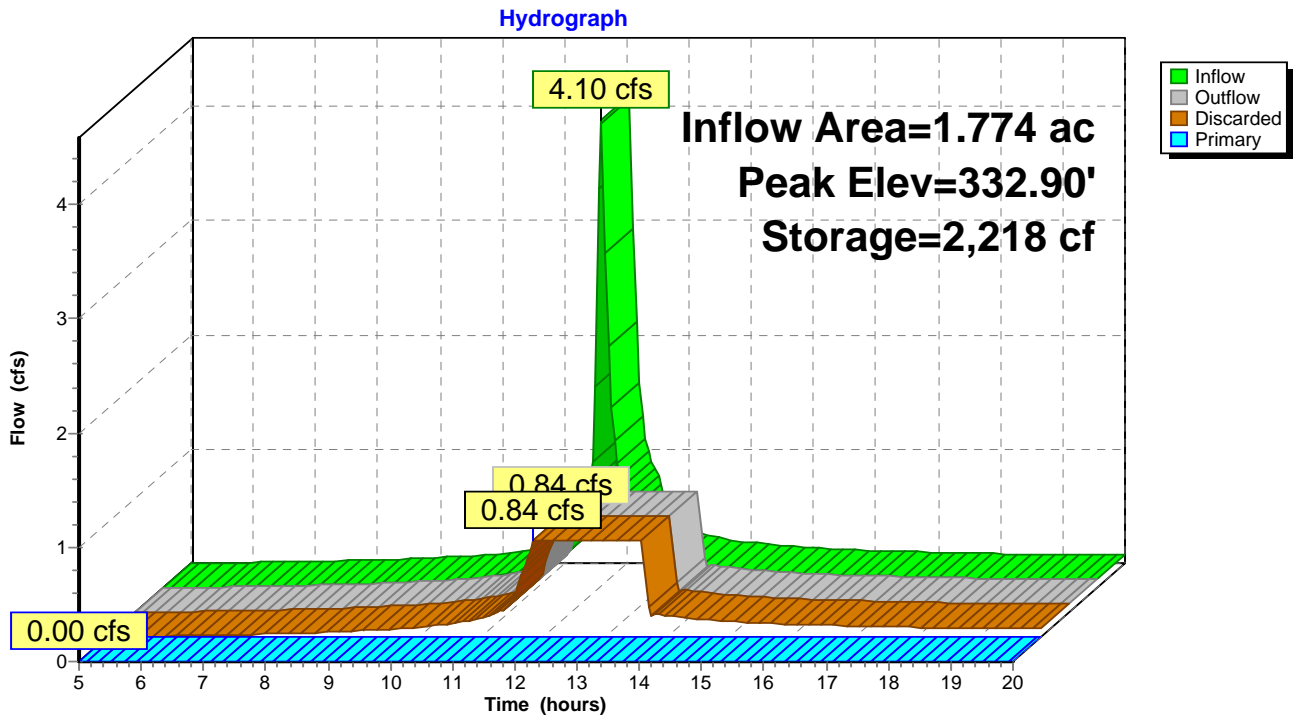
Elevation (feet)	Surf.Area (sq-ft)	Inc.Store (cubic-feet)	Cum.Store (cubic-feet)
331.00	2,427	0	0
335.50	2,427	10,922	10,922

Device	Routing	Invert	Outlet Devices
#1	Primary	328.10'	<b>18.0" Round Culvert</b> L= 30.0' CMP, square edge headwall, Ke= 0.500 Inlet / Outlet Invert= 328.10' / 326.90' S= 0.0400 '/' Cc= 0.900 n= 0.013 Corrugated PE, smooth interior, Flow Area= 1.77 sf
#2	Device 1	334.00'	<b>4.0' long Sharp-Crested Vee/Trap Weir</b> Cv= 2.62 (C= 3.28)
#3	Discarded	331.00'	<b>15.000 in/hr Exfiltration over Surface area</b>

**Discarded OutFlow** Max=0.84 cfs @ 11.85 hrs HW=331.05' (Free Discharge)  
 ↳ **3=Exfiltration** (Exfiltration Controls 0.84 cfs)

**Primary OutFlow** Max=0.00 cfs @ 5.00 hrs HW=331.00' (Free Discharge)  
 ↳ **1=Culvert** (Passes 0.00 cfs of 12.48 cfs potential flow)  
 ↳ **2=Sharp-Crested Vee/Trap Weir** ( Controls 0.00 cfs)

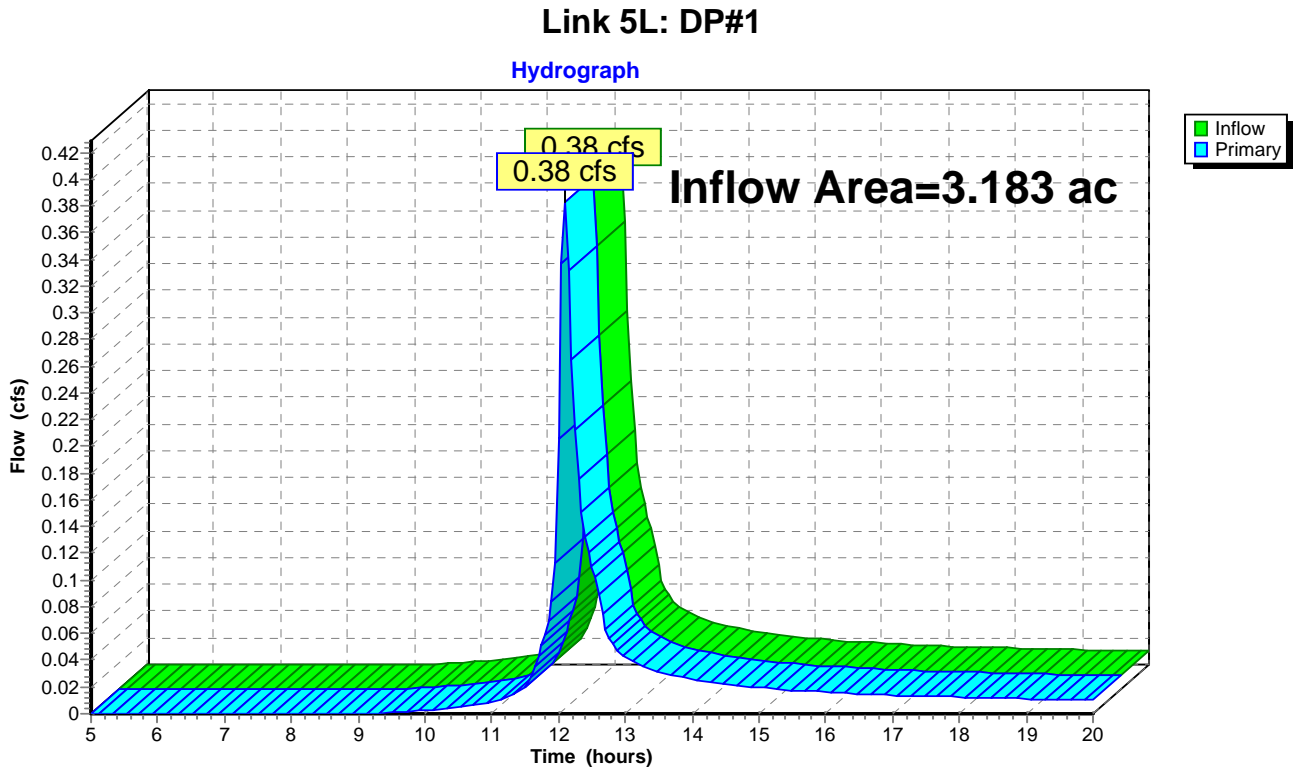
### Pond 9P: Infiltration Basin #2



### Summary for Link 5L: DP#1

Inflow Area = 3.183 ac, 47.19% Impervious, Inflow Depth > 0.10" for 1-yr event  
Inflow = 0.38 cfs @ 12.10 hrs, Volume= 0.026 af  
Primary = 0.38 cfs @ 12.10 hrs, Volume= 0.026 af, Atten= 0%, Lag= 0.0 min

Primary outflow = Inflow, Time Span= 5.00-20.00 hrs, dt= 0.05 hrs



**Summary for Subcatchment 3S: Post Area 1A**

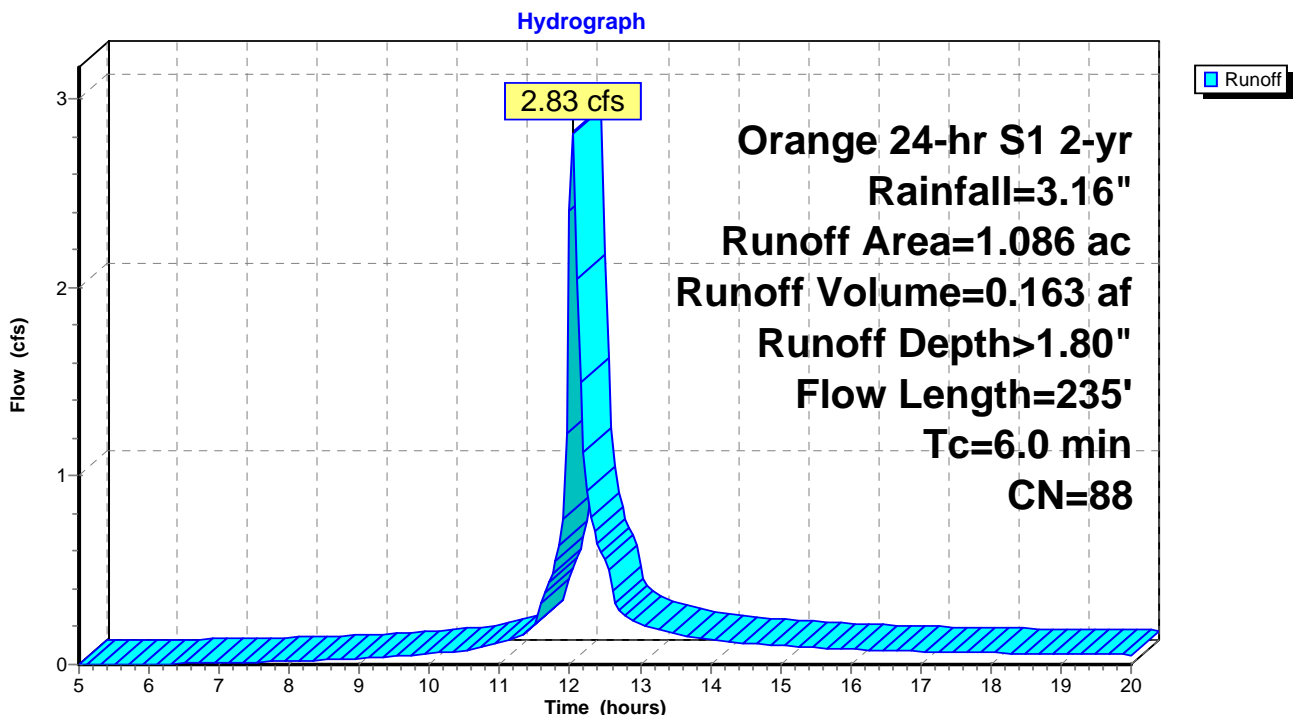
Runoff = 2.83 cfs @ 12.04 hrs, Volume= 0.163 af, Depth> 1.80"

Runoff by SCS TR-20 method, UH=SCS, Weighted-CN, Time Span= 5.00-20.00 hrs, dt= 0.05 hrs  
 Orange 24-hr S1 2-yr Rainfall=3.16"

Area (ac)	CN	Description
* 0.302	98	Proposed Pavement
* 0.107	98	Proposed Building
* 0.024	98	Proposed Sidewalk
0.236	80	>75% Grass cover, Good, HSG D
0.417	82	Woods/grass comb., Fair, HSG D
1.086	88	Weighted Average
0.653		60.13% Pervious Area
0.433		39.87% Impervious Area

Tc (min)	Length (feet)	Slope (ft/ft)	Velocity (ft/sec)	Capacity (cfs)	Description
0.6	50	0.0400	1.50		<b>Sheet Flow, Reach A-B</b> Smooth surfaces n= 0.011 P2= 2.90"
0.4	185	0.0190	8.19	14.48	<b>Pipe Channel, Rach B-C</b> 18.0" Round Area= 1.8 sf Perim= 4.7' r= 0.38' n= 0.013 Corrugated PE, smooth interior
5.0					<b>Direct Entry,</b>
6.0	235	Total			

**Subcatchment 3S: Post Area 1A**



**Summary for Subcatchment 4S: Post Area 1B**

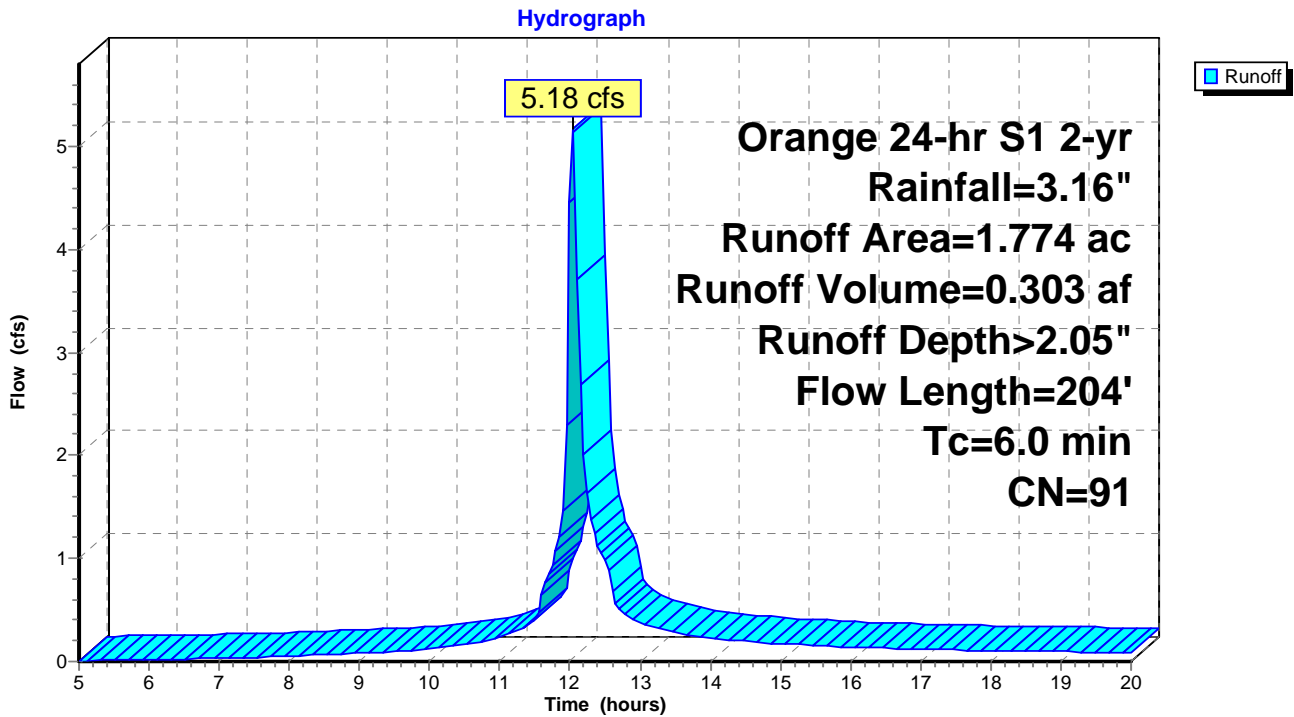
Runoff = 5.18 cfs @ 12.04 hrs, Volume= 0.303 af, Depth> 2.05"

Runoff by SCS TR-20 method, UH=SCS, Weighted-CN, Time Span= 5.00-20.00 hrs, dt= 0.05 hrs  
 Orange 24-hr S1 2-yr Rainfall=3.16"

Area (ac)	CN	Description
* 0.798	98	Proposed Pavement
* 0.208	98	Proposed Building
* 0.031	98	Proposed Sidewalk
0.469	80	>75% Grass cover, Good, HSG D
0.268	82	Woods/grass comb., Fair, HSG D
1.774	91	Weighted Average
0.737		41.54% Pervious Area
1.037		58.46% Impervious Area

Tc (min)	Length (feet)	Slope (ft/ft)	Velocity (ft/sec)	Capacity (cfs)	Description
2.1	10	0.0800	0.08		<b>Sheet Flow, Reach A-B</b> Woods: Light underbrush n= 0.400 P2= 2.90"
0.1	30	0.3300	9.25		<b>Shallow Concentrated Flow, Reach B-C</b> Unpaved Kv= 16.1 fps
0.4	110	0.0500	4.54		<b>Shallow Concentrated Flow, Reach C-D</b> Paved Kv= 20.3 fps
0.2	54	0.0090	5.64	9.97	<b>Pipe Channel, Reach D-E</b> 18.0" Round Area= 1.8 sf Perim= 4.7' r= 0.38' n= 0.013 Corrugated PE, smooth interior
3.2					<b>Direct Entry,</b>
6.0	204	Total			

Subcatchment 4S: Post Area 1B



**Summary for Subcatchment 6S: Post Area 1**

Runoff = 0.54 cfs @ 12.10 hrs, Volume= 0.037 af, Depth> 1.36"

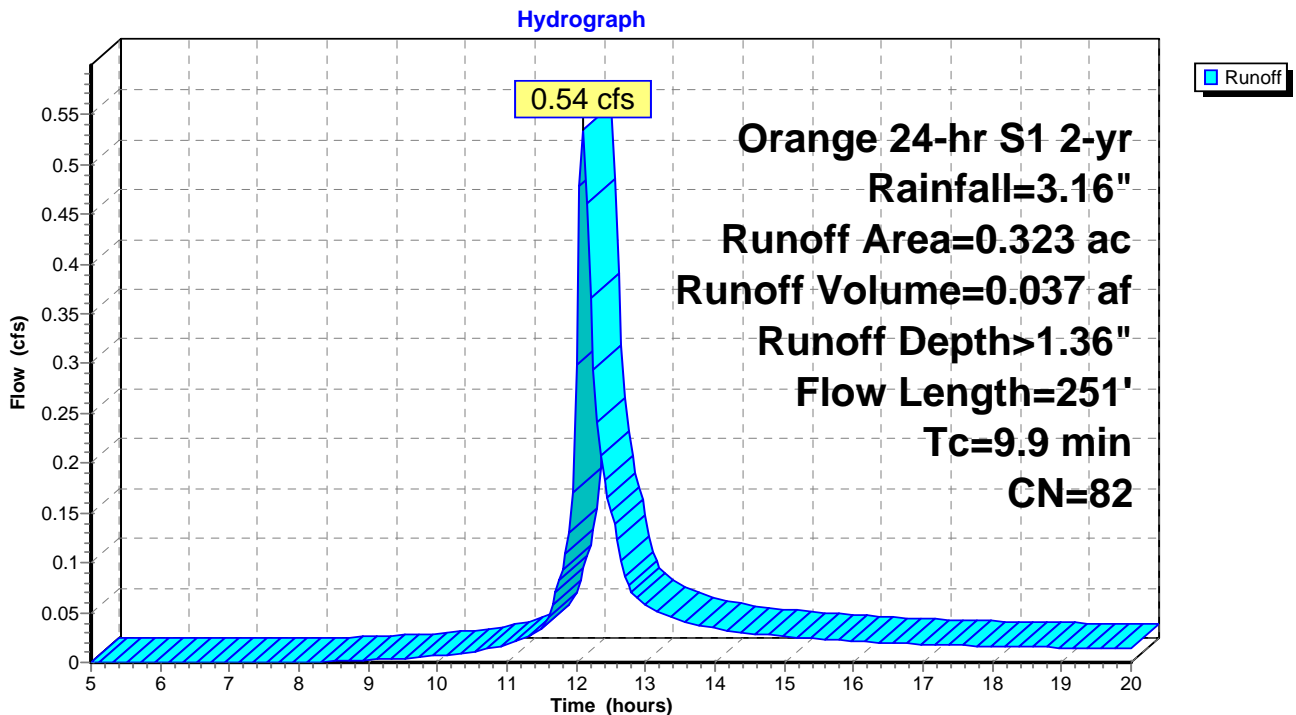
Runoff by SCS TR-20 method, UH=SCS, Weighted-CN, Time Span= 5.00-20.00 hrs, dt= 0.05 hrs  
 Orange 24-hr S1 2-yr Rainfall=3.16"

Area (ac)	CN	Description
0.291	80	>75% Grass cover, Good, HSG D
* 0.032	98	Proposed Pavement
0.323	82	Weighted Average
0.291		90.09% Pervious Area
0.032		9.91% Impervious Area

Tc (min)	Length (feet)	Slope (ft/ft)	Velocity (ft/sec)	Capacity (cfs)	Description
7.3	96	0.0430	0.22		<b>Sheet Flow, Reach A-B</b> Grass: Short n= 0.150 P2= 2.90"
2.6	155	0.0004	0.98	0.77	<b>Pipe Channel, RCP_Round 12"</b> 12.0" Round Area= 0.8 sf Perim= 3.1' r= 0.25' n= 0.012 Concrete pipe, finished
9.9	251	Total			

**Subcatchment 6S: Post Area 1**



**Summary for Subcatchment 7S: Post Area 2**

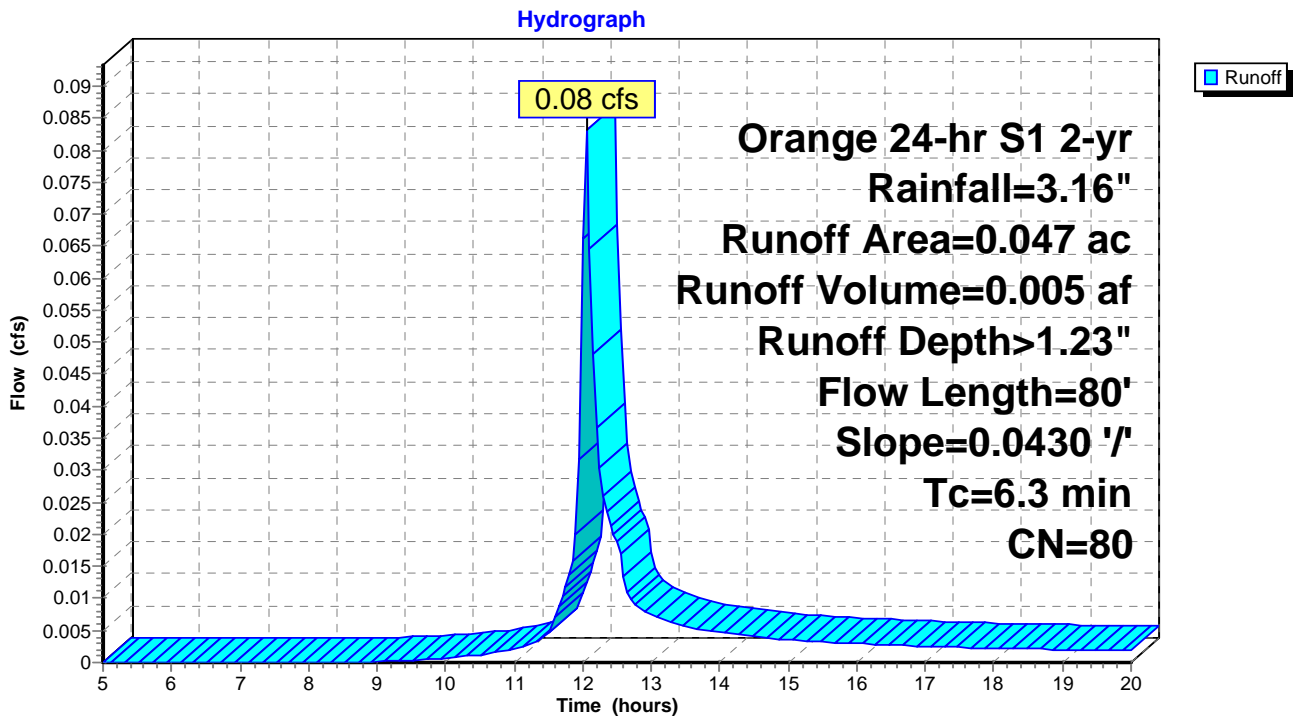
Runoff = 0.08 cfs @ 12.05 hrs, Volume= 0.005 af, Depth> 1.23"

Runoff by SCS TR-20 method, UH=SCS, Weighted-CN, Time Span= 5.00-20.00 hrs, dt= 0.05 hrs  
 Orange 24-hr S1 2-yr Rainfall=3.16"

Area (ac)	CN	Description
0.047	80	>75% Grass cover, Good, HSG D
0.047		100.00% Pervious Area

Tc (min)	Length (feet)	Slope (ft/ft)	Velocity (ft/sec)	Capacity (cfs)	Description
6.3	80	0.0430	0.21		Sheet Flow, Reach A-B Grass: Short n= 0.150 P2= 2.90"

**Subcatchment 7S: Post Area 2**





**Summary for Pond 8P: Infiltration Basin#1**

Inflow Area = 1.086 ac, 39.87% Impervious, Inflow Depth > 1.80" for 2-yr event  
 Inflow = 2.83 cfs @ 12.04 hrs, Volume= 0.163 af  
 Outflow = 0.87 cfs @ 11.95 hrs, Volume= 0.163 af, Atten= 69%, Lag= 0.0 min  
 Discarded = 0.87 cfs @ 11.95 hrs, Volume= 0.163 af  
 Primary = 0.00 cfs @ 5.00 hrs, Volume= 0.000 af

Routing by Stor-Ind method, Time Span= 5.00-20.00 hrs, dt= 0.05 hrs  
 Peak Elev= 331.27' @ 12.27 hrs Surf.Area= 2,500 sf Storage= 1,106 cf

Plug-Flow detention time= 6.6 min calculated for 0.163 af (100% of inflow)  
 Center-of-Mass det. time= 6.4 min ( 788.8 - 782.4 )

Volume	Invert	Avail.Storage	Storage Description
#1	330.20'	3,248 cf	<b>Custom Stage Data (Prismatic)</b> Listed below (Recalc) 10,050 cf Overall - 1,929 cf Embedded = 8,121 cf x 40.0% Voids
#2	331.22'	1,929 cf	<b>ADS StormTech SC-740 +Cap</b> x 42 Inside #1 Effective Size= 44.6"W x 30.0"H => 6.45 sf x 7.12'L = 45.9 cf Overall Size= 51.0"W x 30.0"H x 7.56'L with 0.44' Overlap 6 Rows of 7 Chambers
		5,178 cf	Total Available Storage

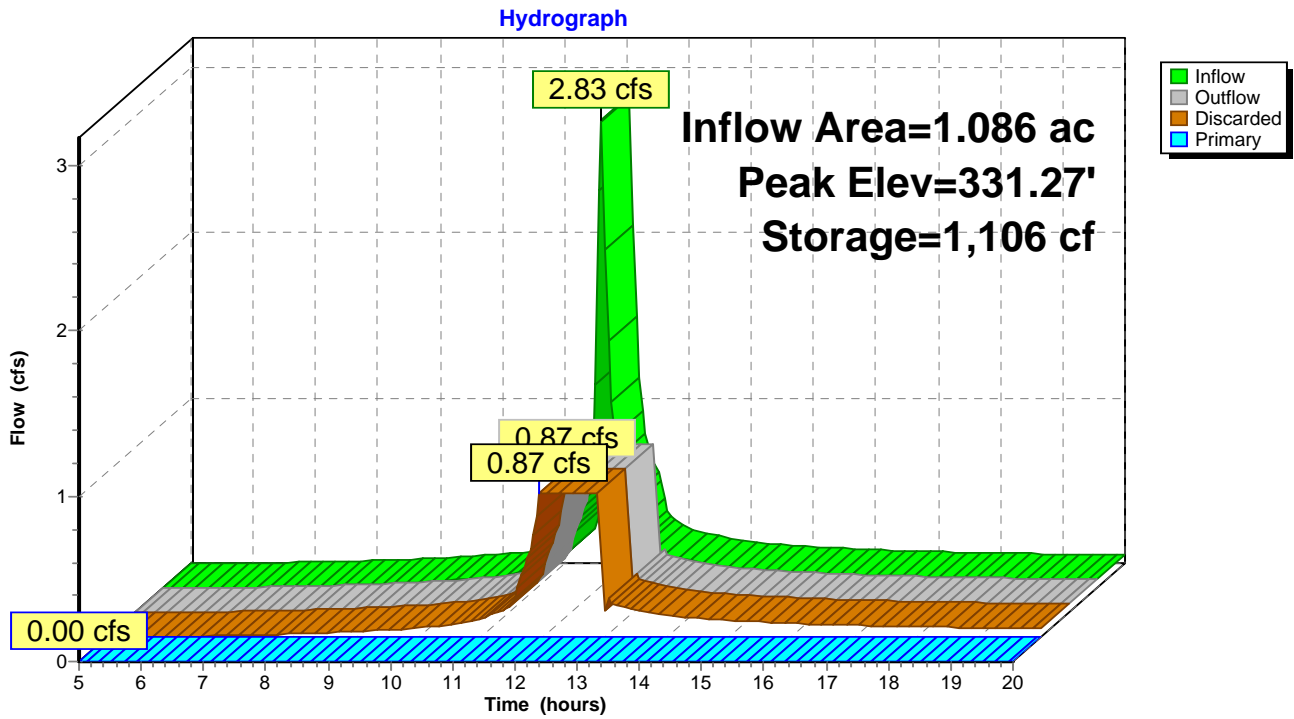
Elevation (feet)	Surf.Area (sq-ft)	Inc.Store (cubic-feet)	Cum.Store (cubic-feet)
330.20	2,500	0	0
334.22	2,500	10,050	10,050

Device	Routing	Invert	Outlet Devices
#1	Primary	328.10'	<b>18.0" Round Culvert</b> L= 30.0' CMP, square edge headwall, Ke= 0.500 Inlet / Outlet Invert= 328.10' / 326.90' S= 0.0400 '/' Cc= 0.900 n= 0.013 Corrugated PE, smooth interior, Flow Area= 1.77 sf
#2	Device 1	333.75'	<b>4.0' long Sharp-Crested Vee/Trap Weir</b> Cv= 2.62 (C= 3.28)
#3	Discarded	330.20'	<b>15.000 in/hr Exfiltration over Surface area</b>

**Discarded OutFlow** Max=0.87 cfs @ 11.95 hrs HW=330.27' (Free Discharge)  
 ↳ **3=Exfiltration** (Exfiltration Controls 0.87 cfs)

**Primary OutFlow** Max=0.00 cfs @ 5.00 hrs HW=330.20' (Free Discharge)  
 ↳ **1=Culvert** (Passes 0.00 cfs of 9.89 cfs potential flow)  
 ↳ **2=Sharp-Crested Vee/Trap Weir** ( Controls 0.00 cfs)

### Pond 8P: Infiltration Basin#1



**Summary for Pond 9P: Infiltration Basin #2**

[82] Warning: Early inflow requires earlier time span

Inflow Area = 1.774 ac, 58.46% Impervious, Inflow Depth > 2.05" for 2-yr event  
 Inflow = 5.18 cfs @ 12.04 hrs, Volume= 0.303 af  
 Outflow = 0.84 cfs @ 11.75 hrs, Volume= 0.303 af, Atten= 84%, Lag= 0.0 min  
 Discarded = 0.84 cfs @ 11.75 hrs, Volume= 0.303 af  
 Primary = 0.00 cfs @ 5.00 hrs, Volume= 0.000 af

Routing by Stor-Ind method, Time Span= 5.00-20.00 hrs, dt= 0.05 hrs  
 Peak Elev= 333.58' @ 12.55 hrs Surf.Area= 2,427 sf Storage= 3,456 cf

Plug-Flow detention time= 24.2 min calculated for 0.302 af (100% of inflow)  
 Center-of-Mass det. time= 24.0 min ( 794.2 - 770.2 )

Volume	Invert	Avail.Storage	Storage Description
#1	331.00'	3,266 cf	<b>Custom Stage Data (Prismatic)</b> Listed below (Recalc) 10,922 cf Overall - 2,756 cf Embedded = 8,165 cf x 40.0% Voids
#2	332.50'	2,756 cf	<b>ADS_StormTech SC-740 +Cap</b> x 60 Inside #1 Effective Size= 44.6"W x 30.0"H => 6.45 sf x 7.12'L = 45.9 cf Overall Size= 51.0"W x 30.0"H x 7.56'L with 0.44' Overlap 6 Rows of 10 Chambers
		6,022 cf	Total Available Storage

Elevation (feet)	Surf.Area (sq-ft)	Inc.Store (cubic-feet)	Cum.Store (cubic-feet)
331.00	2,427	0	0
335.50	2,427	10,922	10,922

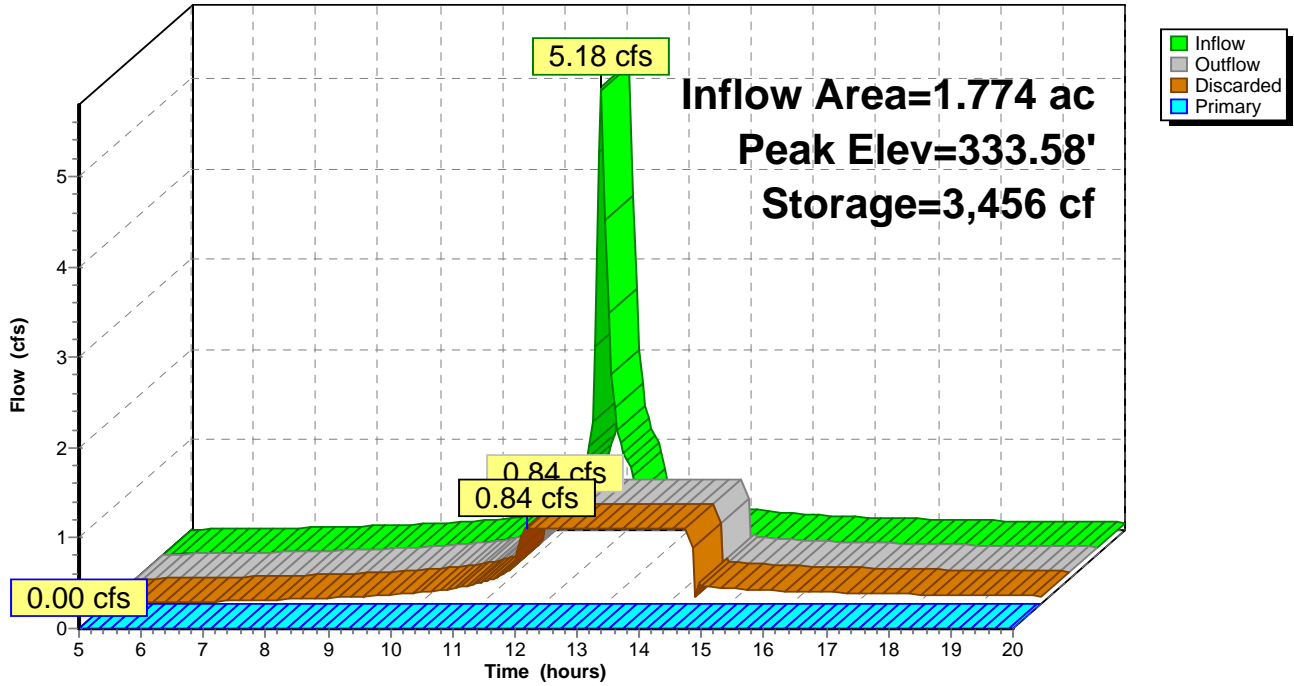
Device	Routing	Invert	Outlet Devices
#1	Primary	328.10'	<b>18.0" Round Culvert</b> L= 30.0' CMP, square edge headwall, Ke= 0.500 Inlet / Outlet Invert= 328.10' / 326.90' S= 0.0400 '/' Cc= 0.900 n= 0.013 Corrugated PE, smooth interior, Flow Area= 1.77 sf
#2	Device 1	334.00'	<b>4.0' long Sharp-Crested Vee/Trap Weir</b> Cv= 2.62 (C= 3.28)
#3	Discarded	331.00'	<b>15.000 in/hr Exfiltration over Surface area</b>

**Discarded OutFlow** Max=0.84 cfs @ 11.75 hrs HW=331.06' (Free Discharge)  
 ↳ **3=Exfiltration** (Exfiltration Controls 0.84 cfs)

**Primary OutFlow** Max=0.00 cfs @ 5.00 hrs HW=331.00' (Free Discharge)  
 ↳ **1=Culvert** (Passes 0.00 cfs of 12.48 cfs potential flow)  
 ↳ **2=Sharp-Crested Vee/Trap Weir** ( Controls 0.00 cfs)

### Pond 9P: Infiltration Basin #2

Hydrograph



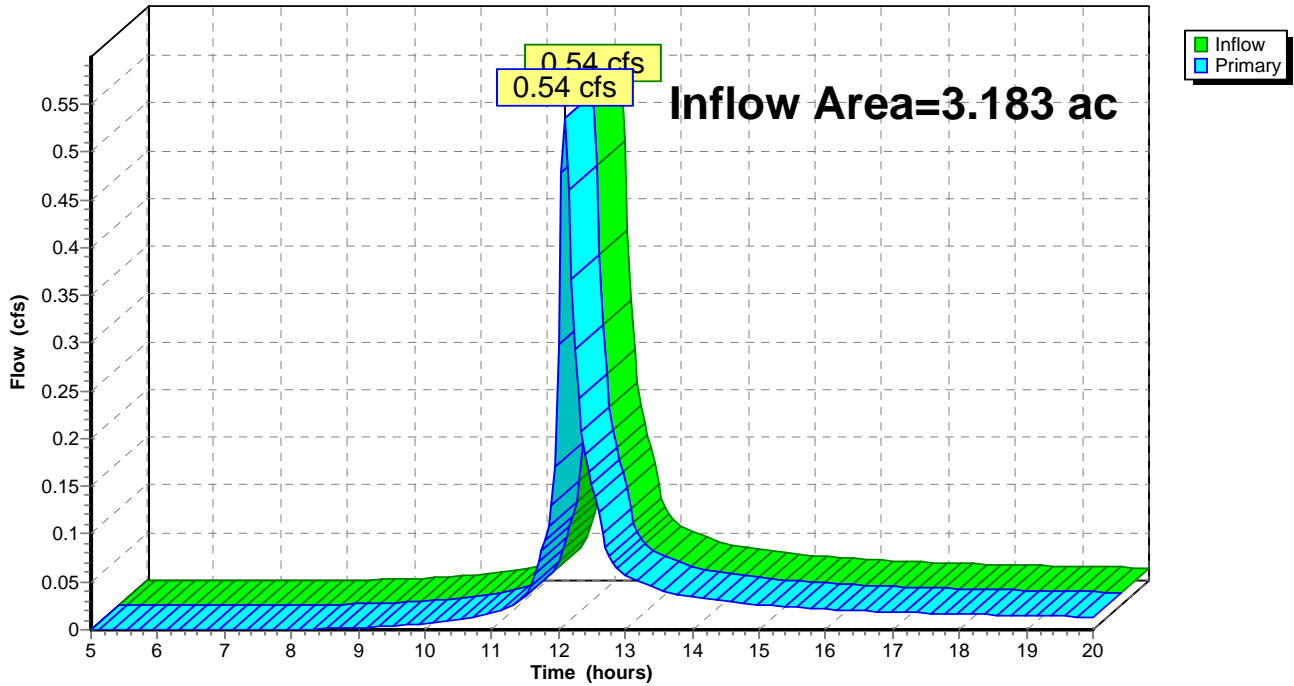
### Summary for Link 5L: DP#1

Inflow Area = 3.183 ac, 47.19% Impervious, Inflow Depth > 0.14" for 2-yr event  
Inflow = 0.54 cfs @ 12.10 hrs, Volume= 0.037 af  
Primary = 0.54 cfs @ 12.10 hrs, Volume= 0.037 af, Atten= 0%, Lag= 0.0 min

Primary outflow = Inflow, Time Span= 5.00-20.00 hrs, dt= 0.05 hrs

### Link 5L: DP#1

Hydrograph



**Summary for Subcatchment 3S: Post Area 1A**

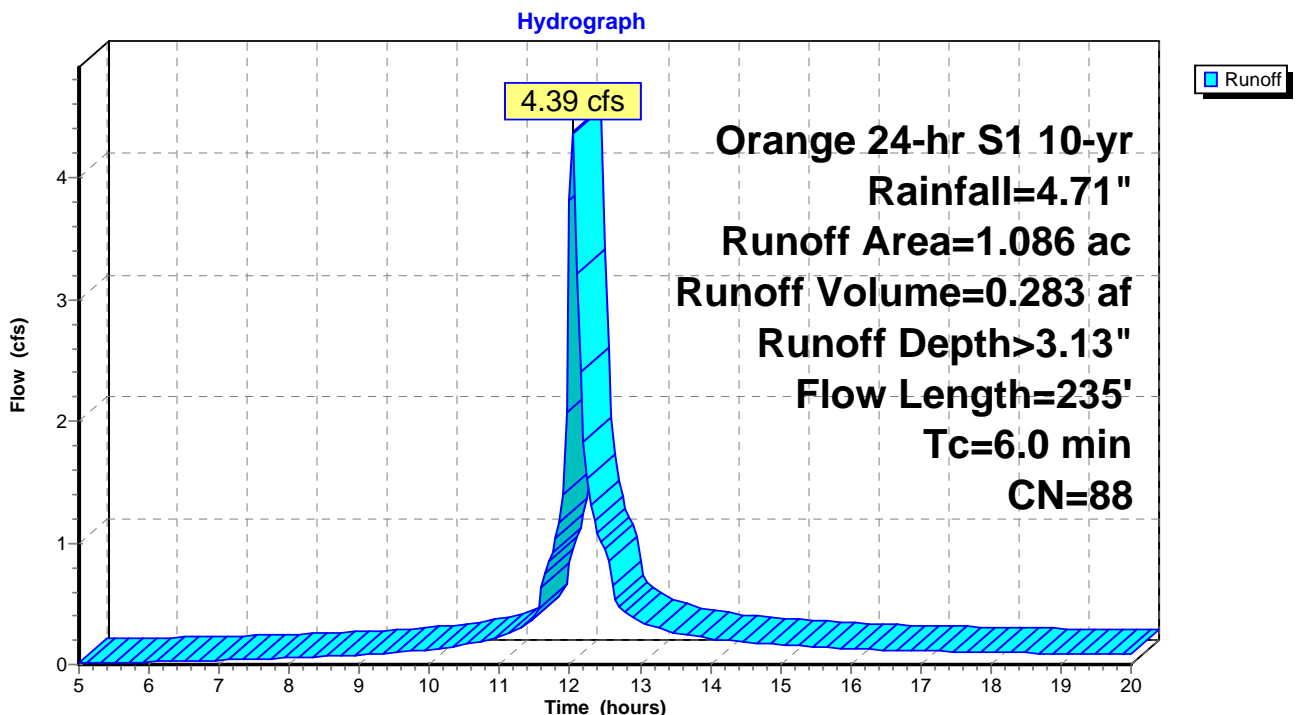
Runoff = 4.39 cfs @ 12.04 hrs, Volume= 0.283 af, Depth> 3.13"

Runoff by SCS TR-20 method, UH=SCS, Weighted-CN, Time Span= 5.00-20.00 hrs, dt= 0.05 hrs  
 Orange 24-hr S1 10-yr Rainfall=4.71"

Area (ac)	CN	Description
* 0.302	98	Proposed Pavement
* 0.107	98	Proposed Building
* 0.024	98	Proposed Sidewalk
0.236	80	>75% Grass cover, Good, HSG D
0.417	82	Woods/grass comb., Fair, HSG D
1.086	88	Weighted Average
0.653		60.13% Pervious Area
0.433		39.87% Impervious Area

Tc (min)	Length (feet)	Slope (ft/ft)	Velocity (ft/sec)	Capacity (cfs)	Description
0.6	50	0.0400	1.50		<b>Sheet Flow, Reach A-B</b> Smooth surfaces n= 0.011 P2= 2.90"
0.4	185	0.0190	8.19	14.48	<b>Pipe Channel, Rach B-C</b> 18.0" Round Area= 1.8 sf Perim= 4.7' r= 0.38' n= 0.013 Corrugated PE, smooth interior
5.0					<b>Direct Entry,</b>
6.0	235	Total			

**Subcatchment 3S: Post Area 1A**



**Summary for Subcatchment 4S: Post Area 1B**

Runoff = 7.68 cfs @ 12.04 hrs, Volume= 0.504 af, Depth> 3.41"

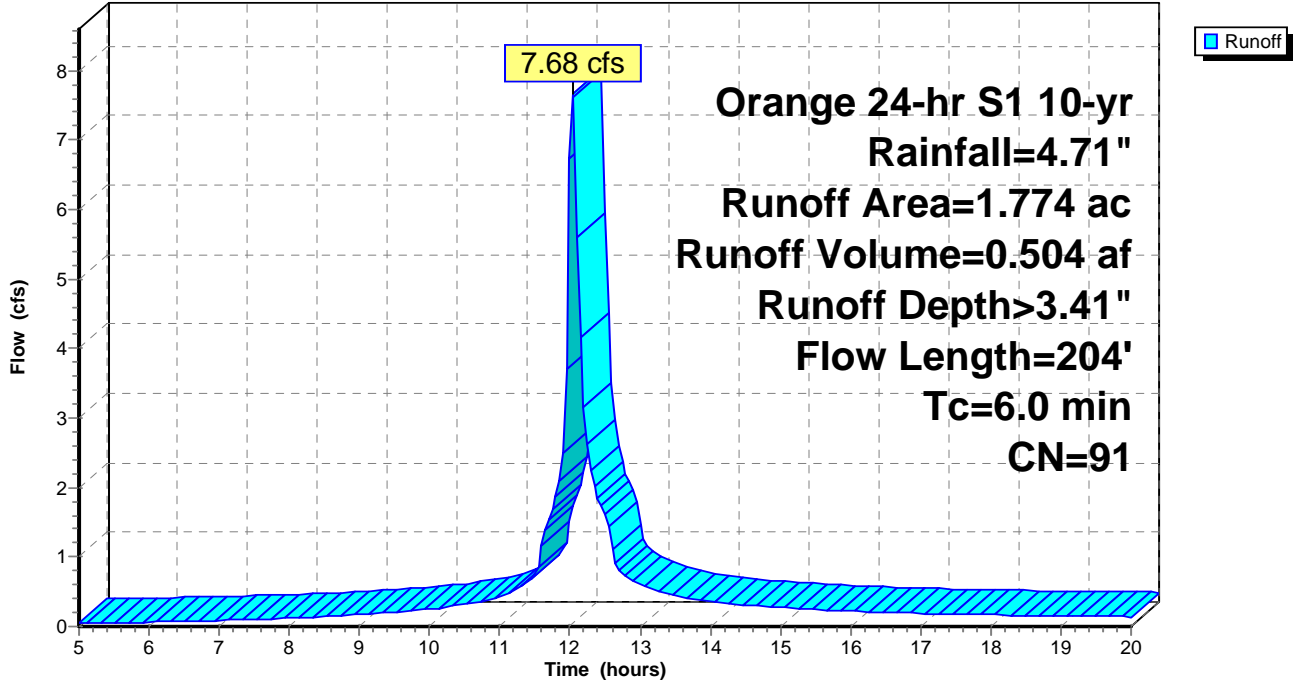
Runoff by SCS TR-20 method, UH=SCS, Weighted-CN, Time Span= 5.00-20.00 hrs, dt= 0.05 hrs  
 Orange 24-hr S1 10-yr Rainfall=4.71"

Area (ac)	CN	Description
* 0.798	98	Proposed Pavement
* 0.208	98	Proposed Building
* 0.031	98	Proposed Sidewalk
0.469	80	>75% Grass cover, Good, HSG D
0.268	82	Woods/grass comb., Fair, HSG D
1.774	91	Weighted Average
0.737		41.54% Pervious Area
1.037		58.46% Impervious Area

Tc (min)	Length (feet)	Slope (ft/ft)	Velocity (ft/sec)	Capacity (cfs)	Description
2.1	10	0.0800	0.08		<b>Sheet Flow, Reach A-B</b> Woods: Light underbrush n= 0.400 P2= 2.90"
0.1	30	0.3300	9.25		<b>Shallow Concentrated Flow, Reach B-C</b> Unpaved Kv= 16.1 fps
0.4	110	0.0500	4.54		<b>Shallow Concentrated Flow, Reach C-D</b> Paved Kv= 20.3 fps
0.2	54	0.0090	5.64	9.97	<b>Pipe Channel, Reach D-E</b> 18.0" Round Area= 1.8 sf Perim= 4.7' r= 0.38' n= 0.013 Corrugated PE, smooth interior
3.2					<b>Direct Entry,</b>
6.0	204	Total			

Subcatchment 4S: Post Area 1B

Hydrograph





**Summary for Subcatchment 6S: Post Area 1**

Runoff = 0.93 cfs @ 12.09 hrs, Volume= 0.069 af, Depth> 2.57"

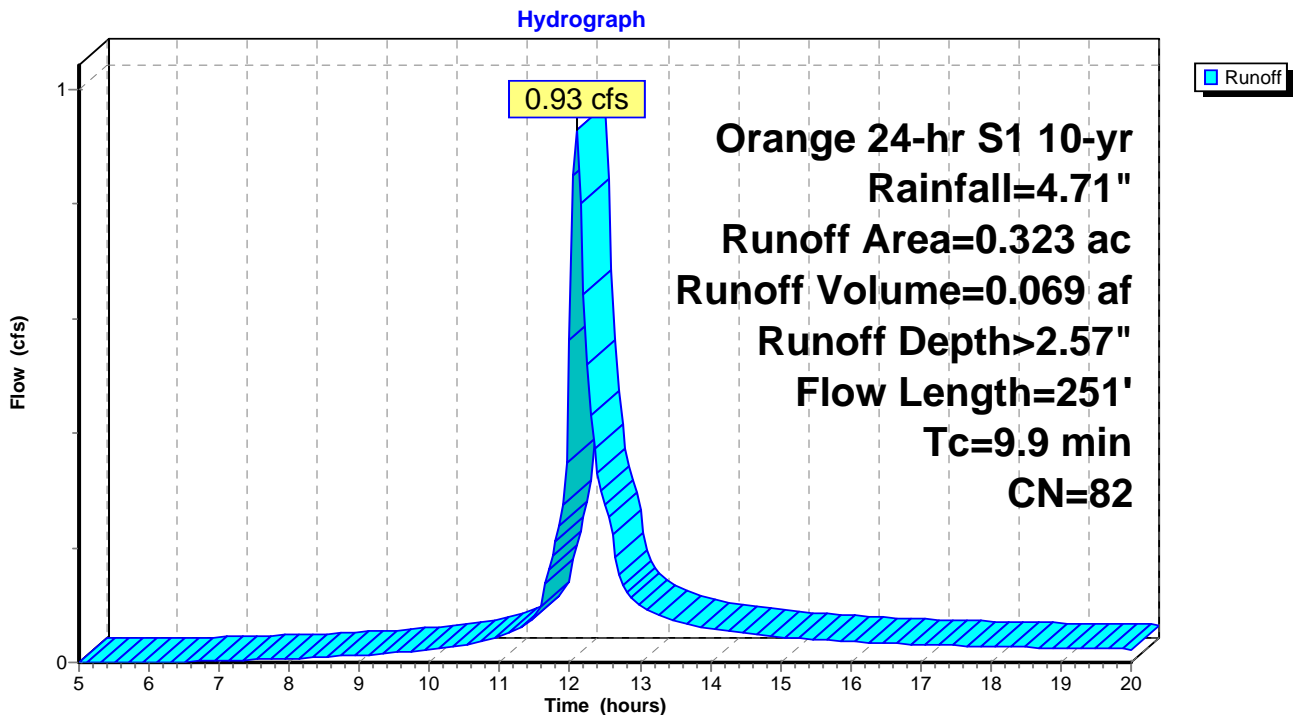
Runoff by SCS TR-20 method, UH=SCS, Weighted-CN, Time Span= 5.00-20.00 hrs, dt= 0.05 hrs  
 Orange 24-hr S1 10-yr Rainfall=4.71"

Area (ac)	CN	Description
0.291	80	>75% Grass cover, Good, HSG D
* 0.032	98	Proposed Pavement
0.323	82	Weighted Average
0.291		90.09% Pervious Area
0.032		9.91% Impervious Area

Tc (min)	Length (feet)	Slope (ft/ft)	Velocity (ft/sec)	Capacity (cfs)	Description
7.3	96	0.0430	0.22		<b>Sheet Flow, Reach A-B</b> Grass: Short n= 0.150 P2= 2.90"
2.6	155	0.0004	0.98	0.77	<b>Pipe Channel, RCP_Round 12"</b> 12.0" Round Area= 0.8 sf Perim= 3.1' r= 0.25' n= 0.012 Concrete pipe, finished
9.9	251	Total			

**Subcatchment 6S: Post Area 1**



**Summary for Subcatchment 7S: Post Area 2**

Runoff = 0.15 cfs @ 12.05 hrs, Volume= 0.009 af, Depth> 2.40"

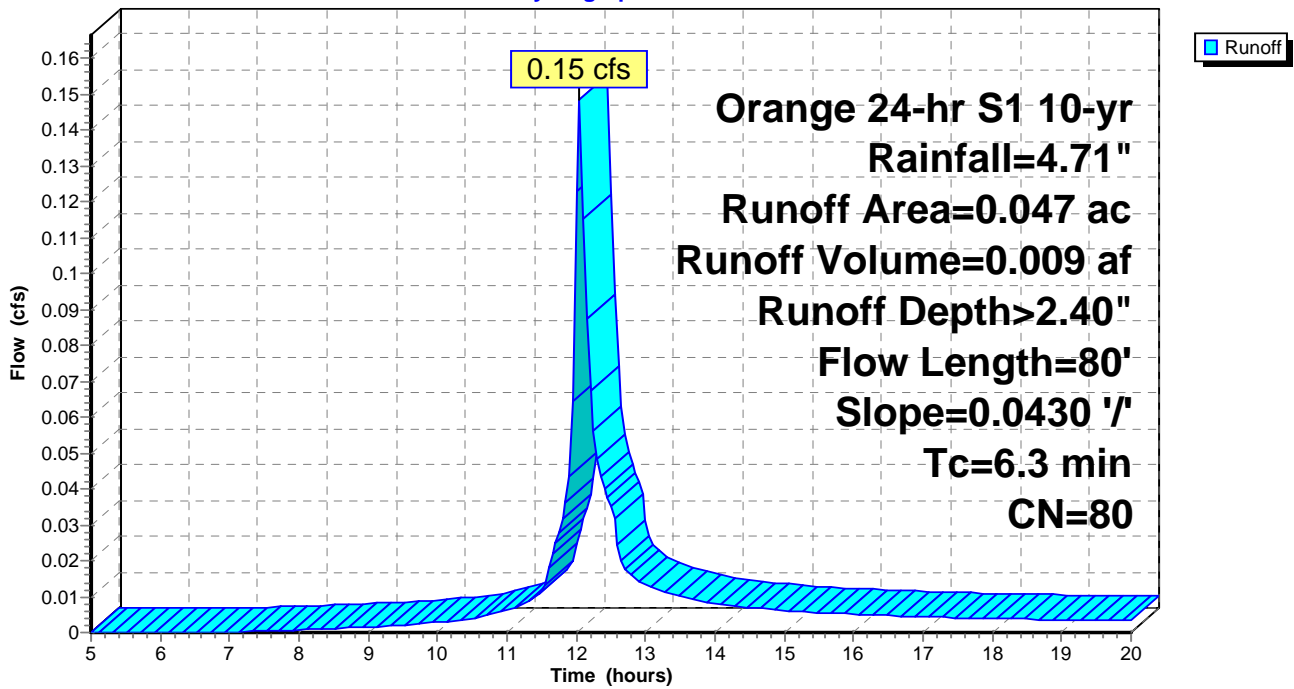
Runoff by SCS TR-20 method, UH=SCS, Weighted-CN, Time Span= 5.00-20.00 hrs, dt= 0.05 hrs  
 Orange 24-hr S1 10-yr Rainfall=4.71"

Area (ac)	CN	Description
0.047	80	>75% Grass cover, Good, HSG D
0.047		100.00% Pervious Area

Tc (min)	Length (feet)	Slope (ft/ft)	Velocity (ft/sec)	Capacity (cfs)	Description
6.3	80	0.0430	0.21		Sheet Flow, Reach A-B Grass: Short n= 0.150 P2= 2.90"

**Subcatchment 7S: Post Area 2**

Hydrograph



**Summary for Pond 8P: Infiltration Basin#1**

[82] Warning: Early inflow requires earlier time span

Inflow Area = 1.086 ac, 39.87% Impervious, Inflow Depth > 3.13" for 10-yr event  
 Inflow = 4.39 cfs @ 12.04 hrs, Volume= 0.283 af  
 Outflow = 0.87 cfs @ 11.75 hrs, Volume= 0.283 af, Atten= 80%, Lag= 0.0 min  
 Discarded = 0.87 cfs @ 11.75 hrs, Volume= 0.283 af  
 Primary = 0.00 cfs @ 5.00 hrs, Volume= 0.000 af

Routing by Stor-Ind method, Time Span= 5.00-20.00 hrs, dt= 0.05 hrs  
 Peak Elev= 332.33' @ 12.53 hrs Surf.Area= 2,500 sf Storage= 2,811 cf

Plug-Flow detention time= 18.0 min calculated for 0.282 af (100% of inflow)  
 Center-of-Mass det. time= 17.8 min ( 785.6 - 767.9 )

Volume	Invert	Avail.Storage	Storage Description
#1	330.20'	3,248 cf	<b>Custom Stage Data (Prismatic)</b> Listed below (Recalc) 10,050 cf Overall - 1,929 cf Embedded = 8,121 cf x 40.0% Voids
#2	331.22'	1,929 cf	<b>ADS_StormTech SC-740 +Cap</b> x 42 Inside #1 Effective Size= 44.6"W x 30.0"H => 6.45 sf x 7.12'L = 45.9 cf Overall Size= 51.0"W x 30.0"H x 7.56'L with 0.44' Overlap 6 Rows of 7 Chambers
		5,178 cf	Total Available Storage

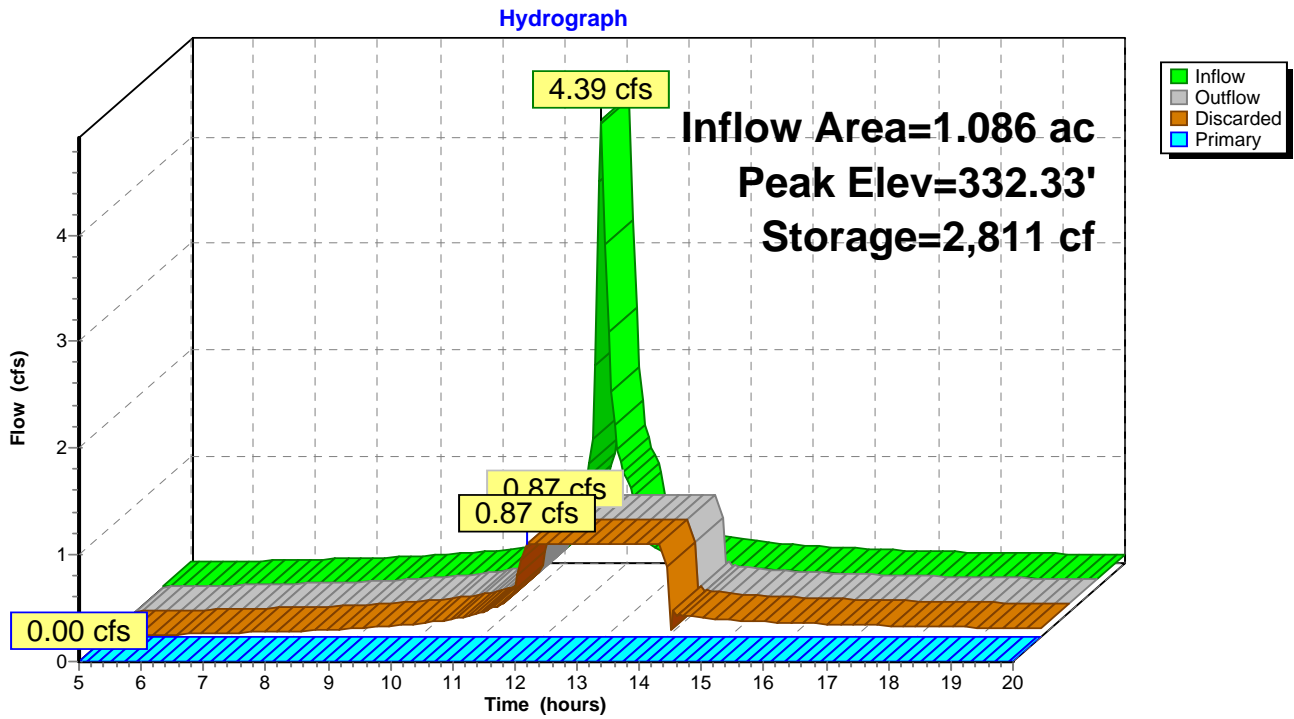
Elevation (feet)	Surf.Area (sq-ft)	Inc.Store (cubic-feet)	Cum.Store (cubic-feet)
330.20	2,500	0	0
334.22	2,500	10,050	10,050

Device	Routing	Invert	Outlet Devices
#1	Primary	328.10'	<b>18.0" Round Culvert</b> L= 30.0' CMP, square edge headwall, Ke= 0.500 Inlet / Outlet Invert= 328.10' / 326.90' S= 0.0400 '/' Cc= 0.900 n= 0.013 Corrugated PE, smooth interior, Flow Area= 1.77 sf
#2	Device 1	333.75'	<b>4.0' long Sharp-Crested Vee/Trap Weir</b> Cv= 2.62 (C= 3.28)
#3	Discarded	330.20'	<b>15.000 in/hr Exfiltration over Surface area</b>

**Discarded OutFlow** Max=0.87 cfs @ 11.75 hrs HW=330.25' (Free Discharge)  
 ↳ **3=Exfiltration** (Exfiltration Controls 0.87 cfs)

**Primary OutFlow** Max=0.00 cfs @ 5.00 hrs HW=330.20' (Free Discharge)  
 ↳ **1=Culvert** (Passes 0.00 cfs of 9.89 cfs potential flow)  
 ↳ **2=Sharp-Crested Vee/Trap Weir** ( Controls 0.00 cfs)

### Pond 8P: Infiltration Basin#1



**Summary for Pond 9P: Infiltration Basin #2**

[82] Warning: Early inflow requires earlier time span

Inflow Area = 1.774 ac, 58.46% Impervious, Inflow Depth > 3.41" for 10-yr event  
 Inflow = 7.68 cfs @ 12.04 hrs, Volume= 0.504 af  
 Outflow = 4.13 cfs @ 12.17 hrs, Volume= 0.504 af, Atten= 46%, Lag= 7.9 min  
 Discarded = 0.84 cfs @ 11.60 hrs, Volume= 0.435 af  
 Primary = 3.29 cfs @ 12.17 hrs, Volume= 0.070 af

Routing by Stor-Ind method, Time Span= 5.00-20.00 hrs, dt= 0.05 hrs  
 Peak Elev= 334.40' @ 12.17 hrs Surf.Area= 2,427 sf Storage= 4,811 cf

Plug-Flow detention time= 27.4 min calculated for 0.504 af (100% of inflow)  
 Center-of-Mass det. time= 27.2 min ( 785.5 - 758.3 )

Volume	Invert	Avail.Storage	Storage Description
#1	331.00'	3,266 cf	<b>Custom Stage Data (Prismatic)</b> Listed below (Recalc) 10,922 cf Overall - 2,756 cf Embedded = 8,165 cf x 40.0% Voids
#2	332.50'	2,756 cf	<b>ADS_StormTech SC-740 +Cap</b> x 60 Inside #1 Effective Size= 44.6"W x 30.0"H => 6.45 sf x 7.12'L = 45.9 cf Overall Size= 51.0"W x 30.0"H x 7.56'L with 0.44' Overlap 6 Rows of 10 Chambers
		6,022 cf	Total Available Storage

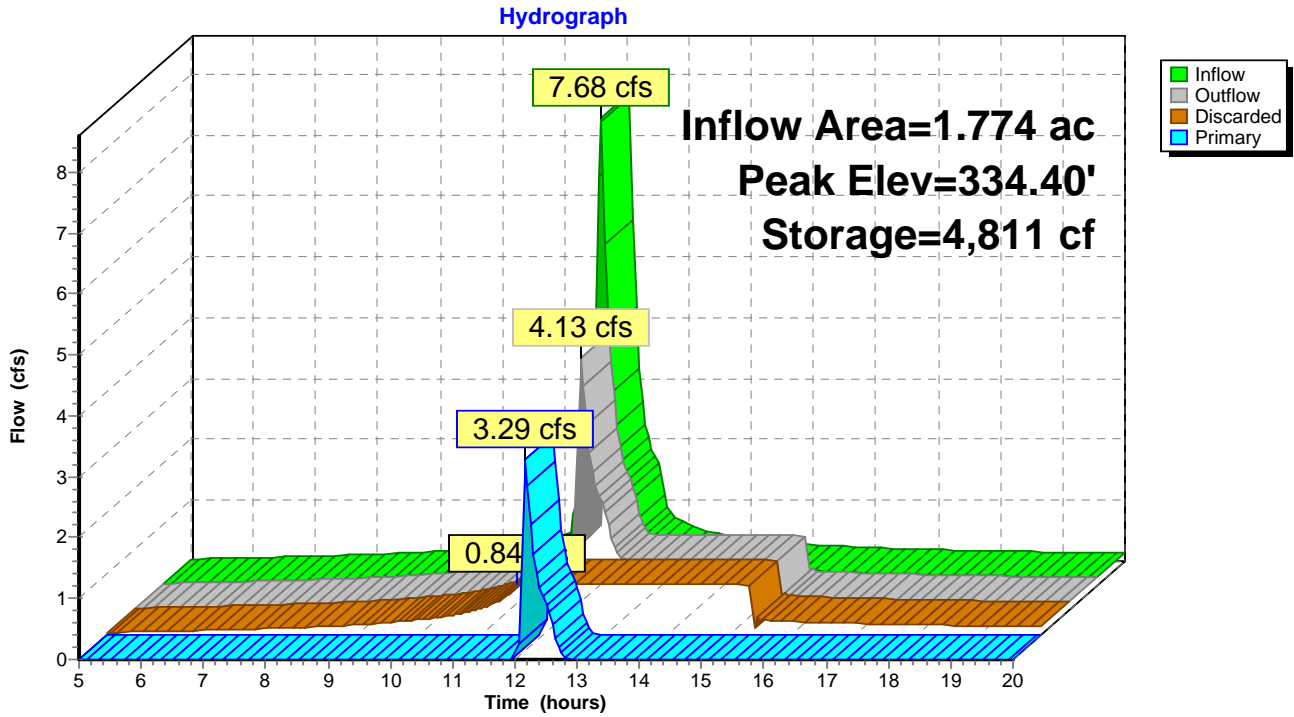
Elevation (feet)	Surf.Area (sq-ft)	Inc.Store (cubic-feet)	Cum.Store (cubic-feet)
331.00	2,427	0	0
335.50	2,427	10,922	10,922

Device	Routing	Invert	Outlet Devices
#1	Primary	328.10'	<b>18.0" Round Culvert</b> L= 30.0' CMP, square edge headwall, Ke= 0.500 Inlet / Outlet Invert= 328.10' / 326.90' S= 0.0400 '/' Cc= 0.900 n= 0.013 Corrugated PE, smooth interior, Flow Area= 1.77 sf
#2	Device 1	334.00'	<b>4.0' long Sharp-Crested Vee/Trap Weir</b> Cv= 2.62 (C= 3.28)
#3	Discarded	331.00'	<b>15.000 in/hr Exfiltration over Surface area</b>

**Discarded OutFlow** Max=0.84 cfs @ 11.60 hrs HW=331.08' (Free Discharge)  
 ↳ **3=Exfiltration** (Exfiltration Controls 0.84 cfs)

**Primary OutFlow** Max=2.95 cfs @ 12.17 hrs HW=334.37' (Free Discharge)  
 ↳ **1=Culvert** (Passes 2.95 cfs of 19.99 cfs potential flow)  
 ↳ **2=Sharp-Crested Vee/Trap Weir** (Weir Controls 2.95 cfs @ 1.99 fps)

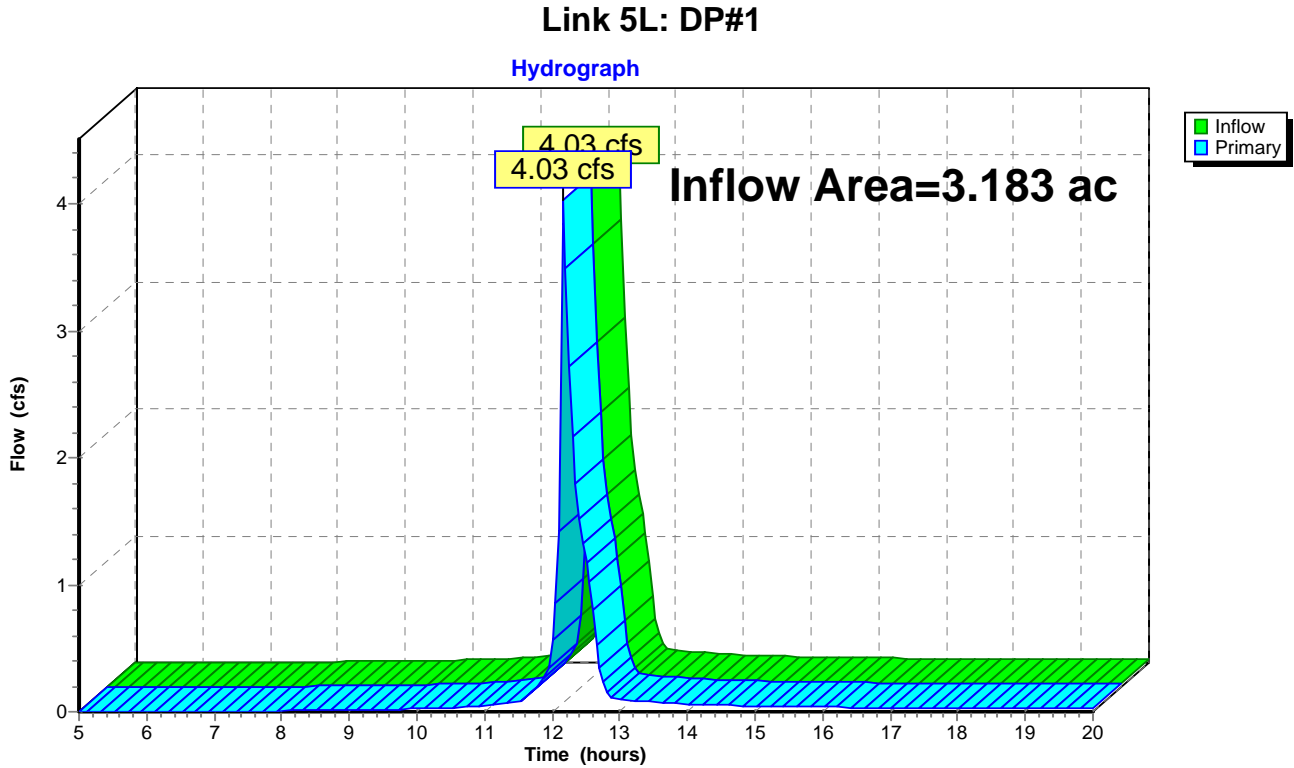
### Pond 9P: Infiltration Basin #2



### Summary for Link 5L: DP#1

Inflow Area = 3.183 ac, 47.19% Impervious, Inflow Depth > 0.52" for 10-yr event  
Inflow = 4.03 cfs @ 12.17 hrs, Volume= 0.139 af  
Primary = 4.03 cfs @ 12.17 hrs, Volume= 0.139 af, Atten= 0%, Lag= 0.0 min

Primary outflow = Inflow, Time Span= 5.00-20.00 hrs, dt= 0.05 hrs



**Summary for Subcatchment 3S: Post Area 1A**

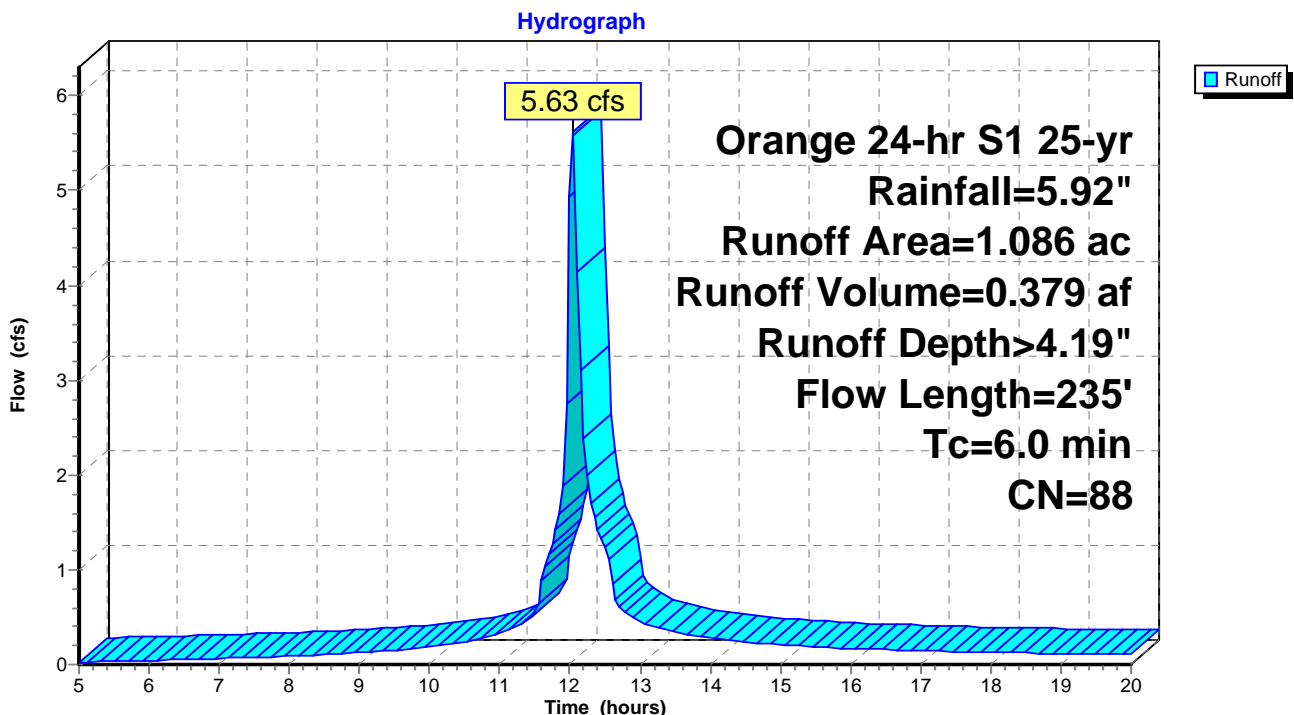
Runoff = 5.63 cfs @ 12.04 hrs, Volume= 0.379 af, Depth> 4.19"

Runoff by SCS TR-20 method, UH=SCS, Weighted-CN, Time Span= 5.00-20.00 hrs, dt= 0.05 hrs  
 Orange 24-hr S1 25-yr Rainfall=5.92"

Area (ac)	CN	Description
* 0.302	98	Proposed Pavement
* 0.107	98	Proposed Building
* 0.024	98	Proposed Sidewalk
0.236	80	>75% Grass cover, Good, HSG D
0.417	82	Woods/grass comb., Fair, HSG D
1.086	88	Weighted Average
0.653		60.13% Pervious Area
0.433		39.87% Impervious Area

Tc (min)	Length (feet)	Slope (ft/ft)	Velocity (ft/sec)	Capacity (cfs)	Description
0.6	50	0.0400	1.50		<b>Sheet Flow, Reach A-B</b> Smooth surfaces n= 0.011 P2= 2.90"
0.4	185	0.0190	8.19	14.48	<b>Pipe Channel, Rach B-C</b> 18.0" Round Area= 1.8 sf Perim= 4.7' r= 0.38' n= 0.013 Corrugated PE, smooth interior
5.0					<b>Direct Entry,</b>
6.0	235	Total			

**Subcatchment 3S: Post Area 1A**





**Summary for Subcatchment 4S: Post Area 1B**

Runoff = 9.66 cfs @ 12.04 hrs, Volume= 0.663 af, Depth> 4.49"

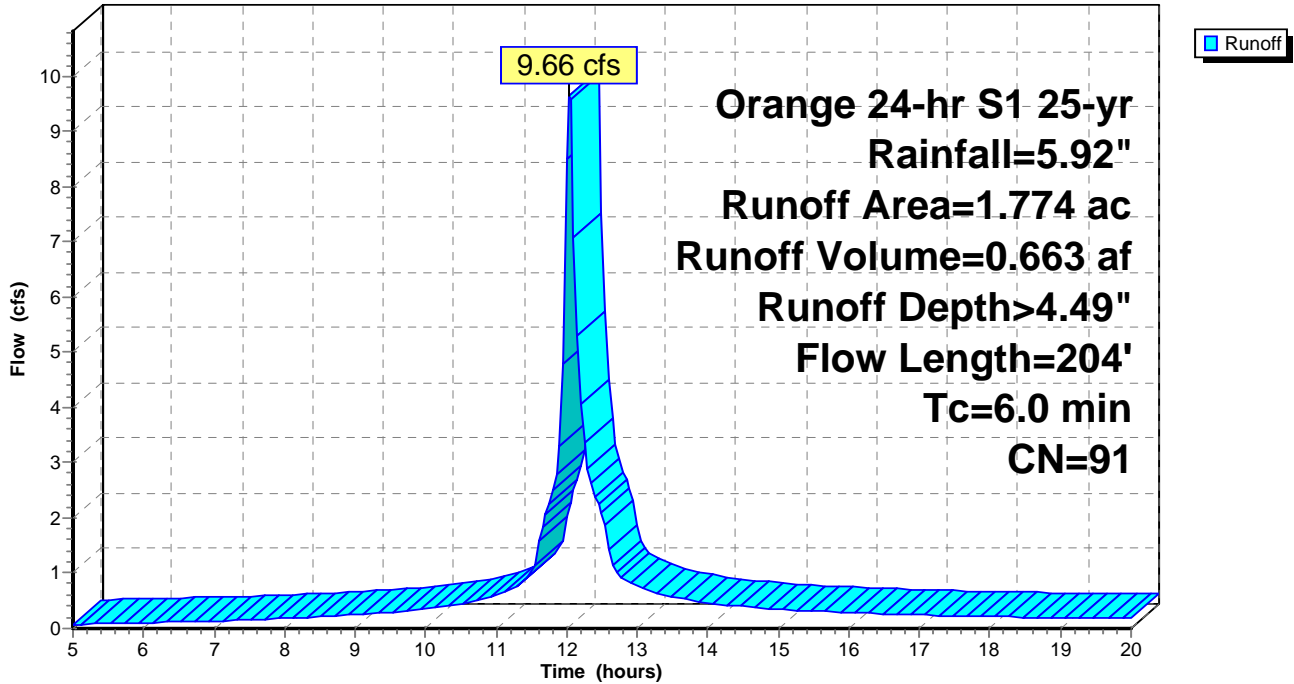
Runoff by SCS TR-20 method, UH=SCS, Weighted-CN, Time Span= 5.00-20.00 hrs, dt= 0.05 hrs  
 Orange 24-hr S1 25-yr Rainfall=5.92"

Area (ac)	CN	Description
* 0.798	98	Proposed Pavement
* 0.208	98	Proposed Building
* 0.031	98	Proposed Sidewalk
0.469	80	>75% Grass cover, Good, HSG D
0.268	82	Woods/grass comb., Fair, HSG D
1.774	91	Weighted Average
0.737		41.54% Pervious Area
1.037		58.46% Impervious Area

Tc (min)	Length (feet)	Slope (ft/ft)	Velocity (ft/sec)	Capacity (cfs)	Description
2.1	10	0.0800	0.08		<b>Sheet Flow, Reach A-B</b> Woods: Light underbrush n= 0.400 P2= 2.90"
0.1	30	0.3300	9.25		<b>Shallow Concentrated Flow, Reach B-C</b> Unpaved Kv= 16.1 fps
0.4	110	0.0500	4.54		<b>Shallow Concentrated Flow, Reach C-D</b> Paved Kv= 20.3 fps
0.2	54	0.0090	5.64	9.97	<b>Pipe Channel, Reach D-E</b> 18.0" Round Area= 1.8 sf Perim= 4.7' r= 0.38' n= 0.013 Corrugated PE, smooth interior
3.2					<b>Direct Entry,</b>
6.0	204	Total			

Subcatchment 4S: Post Area 1B

Hydrograph



**Summary for Subcatchment 6S: Post Area 1**

Runoff = 1.25 cfs @ 12.09 hrs, Volume= 0.097 af, Depth> 3.59"

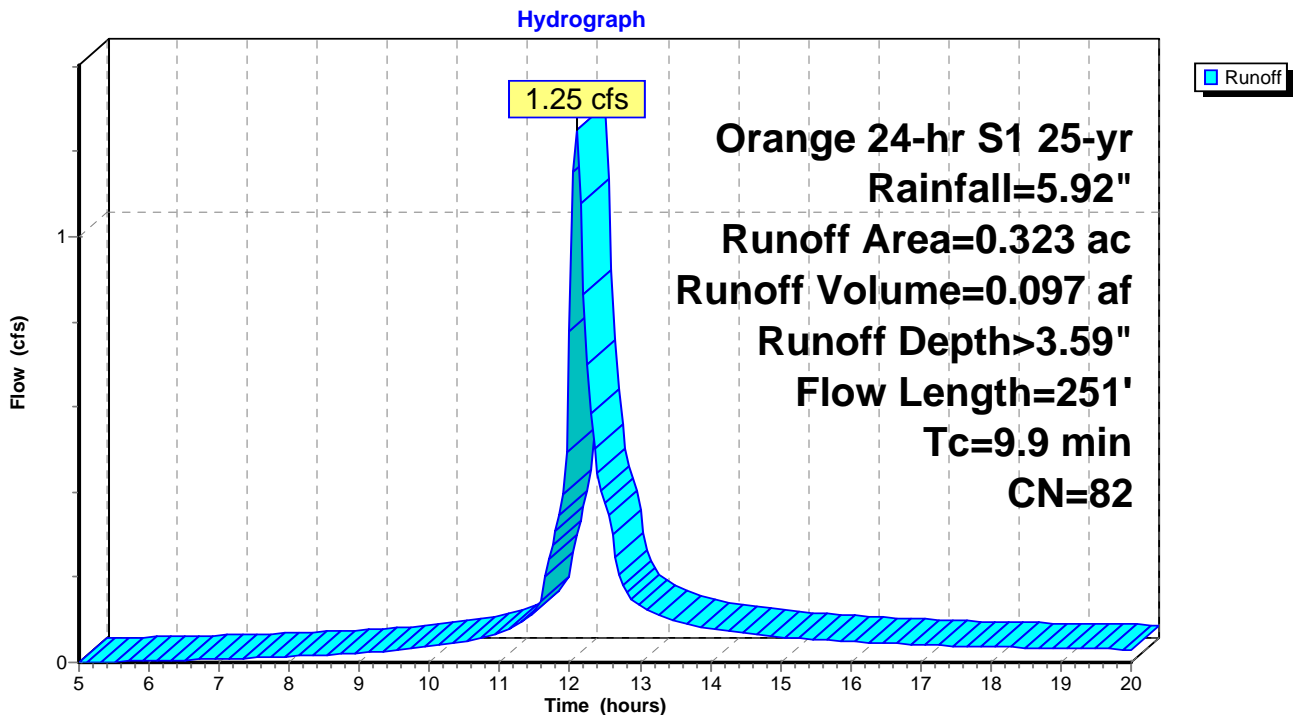
Runoff by SCS TR-20 method, UH=SCS, Weighted-CN, Time Span= 5.00-20.00 hrs, dt= 0.05 hrs  
 Orange 24-hr S1 25-yr Rainfall=5.92"

Area (ac)	CN	Description
0.291	80	>75% Grass cover, Good, HSG D
* 0.032	98	Proposed Pavement
0.323	82	Weighted Average
0.291		90.09% Pervious Area
0.032		9.91% Impervious Area

Tc (min)	Length (feet)	Slope (ft/ft)	Velocity (ft/sec)	Capacity (cfs)	Description
7.3	96	0.0430	0.22		<b>Sheet Flow, Reach A-B</b> Grass: Short n= 0.150 P2= 2.90"
2.6	155	0.0004	0.98	0.77	<b>Pipe Channel, RCP_Round 12"</b> 12.0" Round Area= 0.8 sf Perim= 3.1' r= 0.25' n= 0.012 Concrete pipe, finished
9.9	251	Total			

**Subcatchment 6S: Post Area 1**



**Summary for Subcatchment 7S: Post Area 2**

Runoff = 0.20 cfs @ 12.05 hrs, Volume= 0.013 af, Depth> 3.39"

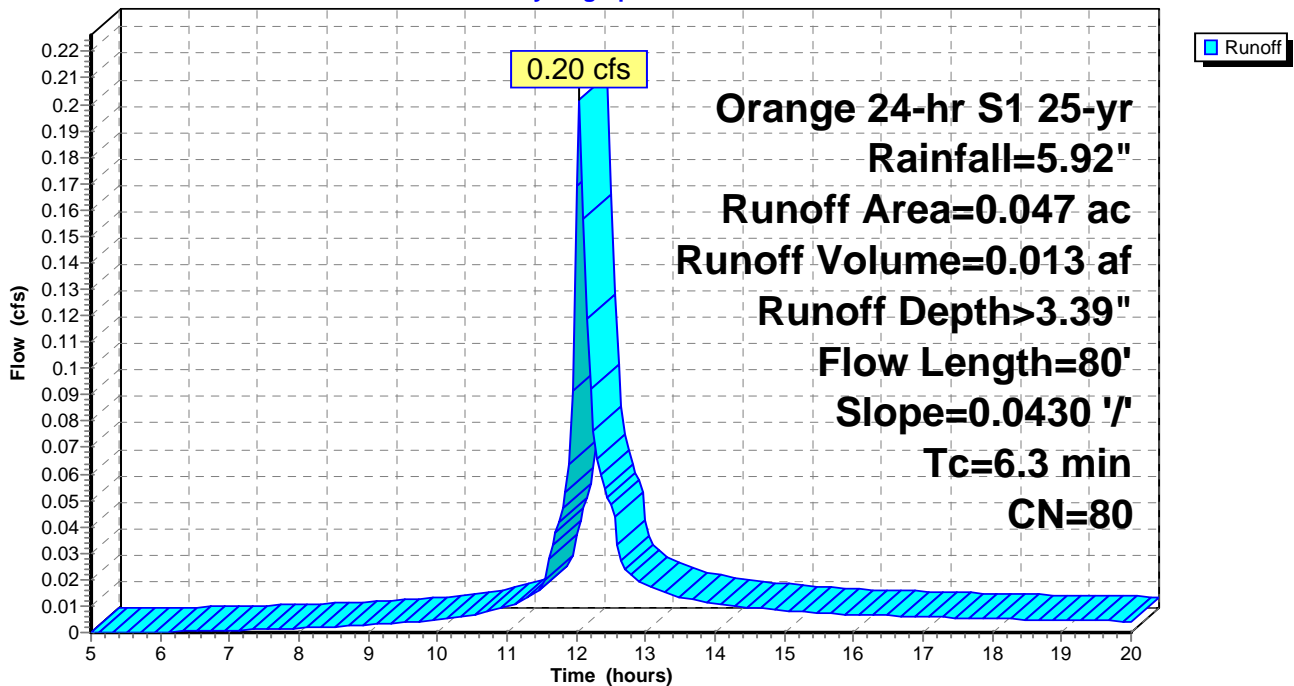
Runoff by SCS TR-20 method, UH=SCS, Weighted-CN, Time Span= 5.00-20.00 hrs, dt= 0.05 hrs  
 Orange 24-hr S1 25-yr Rainfall=5.92"

Area (ac)	CN	Description
0.047	80	>75% Grass cover, Good, HSG D
0.047		100.00% Pervious Area

Tc (min)	Length (feet)	Slope (ft/ft)	Velocity (ft/sec)	Capacity (cfs)	Description
6.3	80	0.0430	0.21		Sheet Flow, Reach A-B Grass: Short n= 0.150 P2= 2.90"

**Subcatchment 7S: Post Area 2**

Hydrograph



**Summary for Pond 8P: Infiltration Basin#1**

[82] Warning: Early inflow requires earlier time span

Inflow Area = 1.086 ac, 39.87% Impervious, Inflow Depth > 4.19" for 25-yr event  
 Inflow = 5.63 cfs @ 12.04 hrs, Volume= 0.379 af  
 Outflow = 0.87 cfs @ 11.65 hrs, Volume= 0.379 af, Atten= 85%, Lag= 0.0 min  
 Discarded = 0.87 cfs @ 11.65 hrs, Volume= 0.379 af  
 Primary = 0.00 cfs @ 5.00 hrs, Volume= 0.000 af

Routing by Stor-Ind method, Time Span= 5.00-20.00 hrs, dt= 0.05 hrs  
 Peak Elev= 333.61' @ 12.60 hrs Surf.Area= 2,500 sf Storage= 4,565 cf

Plug-Flow detention time= 31.5 min calculated for 0.378 af (100% of inflow)  
 Center-of-Mass det. time= 31.2 min ( 792.1 - 760.9 )

Volume	Invert	Avail.Storage	Storage Description
#1	330.20'	3,248 cf	<b>Custom Stage Data (Prismatic)</b> Listed below (Recalc) 10,050 cf Overall - 1,929 cf Embedded = 8,121 cf x 40.0% Voids
#2	331.22'	1,929 cf	<b>ADS_StormTech SC-740 +Cap</b> x 42 Inside #1 Effective Size= 44.6"W x 30.0"H => 6.45 sf x 7.12'L = 45.9 cf Overall Size= 51.0"W x 30.0"H x 7.56'L with 0.44' Overlap 6 Rows of 7 Chambers
		5,178 cf	Total Available Storage

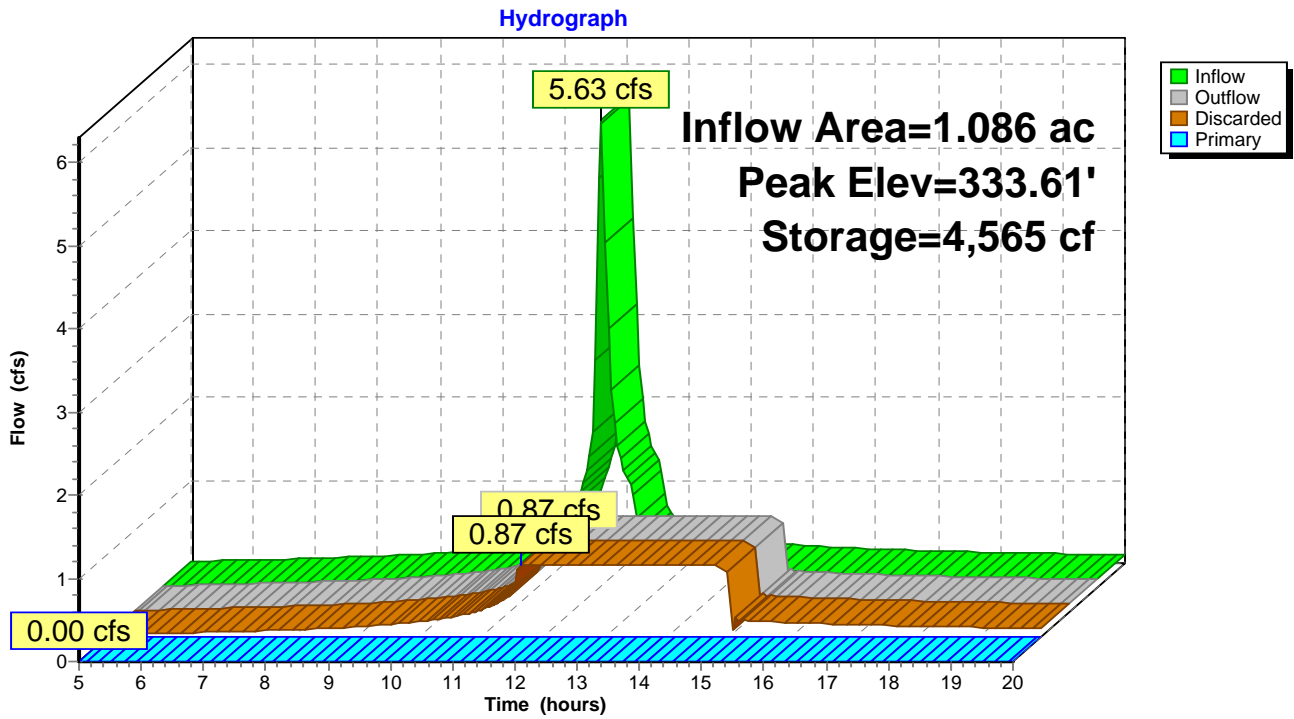
Elevation (feet)	Surf.Area (sq-ft)	Inc.Store (cubic-feet)	Cum.Store (cubic-feet)
330.20	2,500	0	0
334.22	2,500	10,050	10,050

Device	Routing	Invert	Outlet Devices
#1	Primary	328.10'	<b>18.0" Round Culvert</b> L= 30.0' CMP, square edge headwall, Ke= 0.500 Inlet / Outlet Invert= 328.10' / 326.90' S= 0.0400 '/' Cc= 0.900 n= 0.013 Corrugated PE, smooth interior, Flow Area= 1.77 sf
#2	Device 1	333.75'	<b>4.0' long Sharp-Crested Vee/Trap Weir</b> Cv= 2.62 (C= 3.28)
#3	Discarded	330.20'	<b>15.000 in/hr Exfiltration over Surface area</b>

**Discarded OutFlow** Max=0.87 cfs @ 11.65 hrs HW=330.26' (Free Discharge)  
 ↳ **3=Exfiltration** (Exfiltration Controls 0.87 cfs)

**Primary OutFlow** Max=0.00 cfs @ 5.00 hrs HW=330.20' (Free Discharge)  
 ↳ **1=Culvert** (Passes 0.00 cfs of 9.89 cfs potential flow)  
 ↳ **2=Sharp-Crested Vee/Trap Weir** ( Controls 0.00 cfs)

### Pond 8P: Infiltration Basin#1



**Summary for Pond 9P: Infiltration Basin #2**

[82] Warning: Early inflow requires earlier time span

Inflow Area = 1.774 ac, 58.46% Impervious, Inflow Depth > 4.49" for 25-yr event  
 Inflow = 9.66 cfs @ 12.04 hrs, Volume= 0.663 af  
 Outflow = 8.16 cfs @ 12.11 hrs, Volume= 0.663 af, Atten= 16%, Lag= 4.3 min  
 Discarded = 0.84 cfs @ 11.45 hrs, Volume= 0.519 af  
 Primary = 7.32 cfs @ 12.11 hrs, Volume= 0.144 af

Routing by Stor-Ind method, Time Span= 5.00-20.00 hrs, dt= 0.05 hrs  
 Peak Elev= 334.68' @ 12.11 hrs Surf.Area= 2,427 sf Storage= 5,192 cf

Plug-Flow detention time= 25.6 min calculated for 0.661 af (100% of inflow)  
 Center-of-Mass det. time= 25.3 min ( 778.1 - 752.8 )

Volume	Invert	Avail.Storage	Storage Description
#1	331.00'	3,266 cf	<b>Custom Stage Data (Prismatic)</b> Listed below (Recalc) 10,922 cf Overall - 2,756 cf Embedded = 8,165 cf x 40.0% Voids
#2	332.50'	2,756 cf	<b>ADS_StormTech SC-740 +Cap</b> x 60 Inside #1 Effective Size= 44.6"W x 30.0"H => 6.45 sf x 7.12'L = 45.9 cf Overall Size= 51.0"W x 30.0"H x 7.56'L with 0.44' Overlap 6 Rows of 10 Chambers
		6,022 cf	Total Available Storage

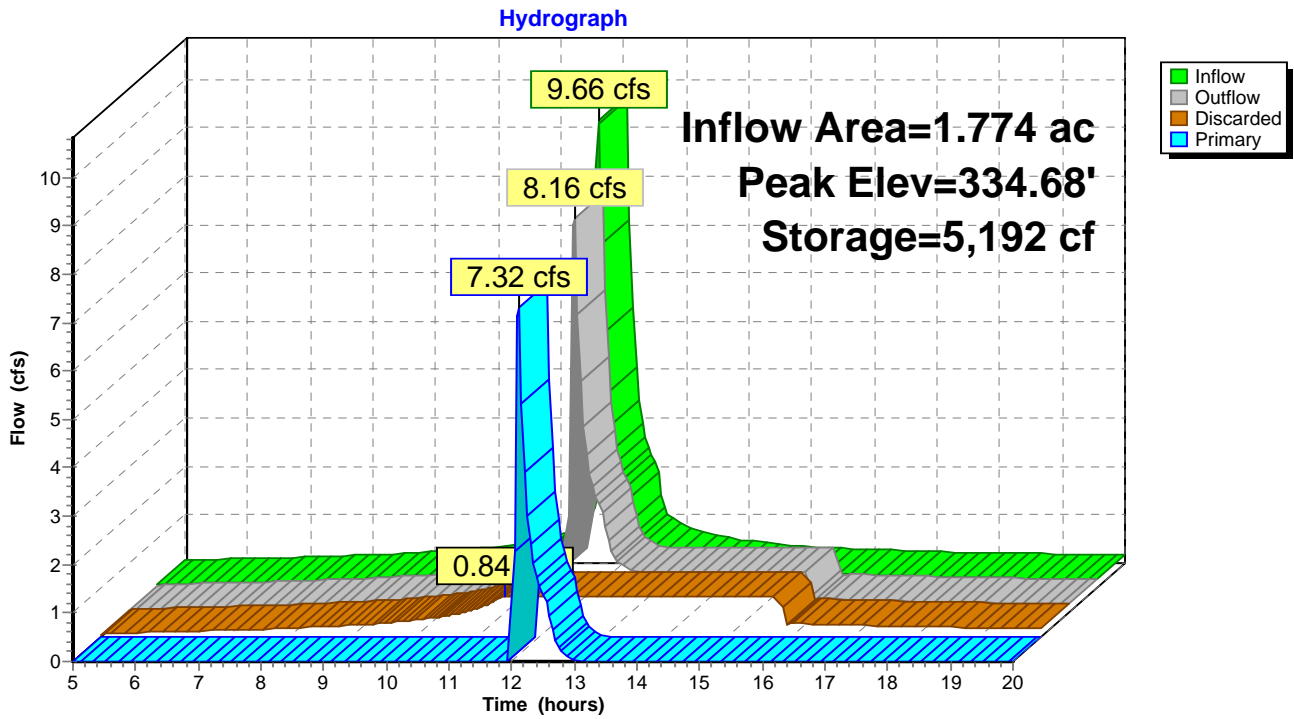
Elevation (feet)	Surf.Area (sq-ft)	Inc.Store (cubic-feet)	Cum.Store (cubic-feet)
331.00	2,427	0	0
335.50	2,427	10,922	10,922

Device	Routing	Invert	Outlet Devices
#1	Primary	328.10'	<b>18.0" Round Culvert</b> L= 30.0' CMP, square edge headwall, Ke= 0.500 Inlet / Outlet Invert= 328.10' / 326.90' S= 0.0400 '/' Cc= 0.900 n= 0.013 Corrugated PE, smooth interior, Flow Area= 1.77 sf
#2	Device 1	334.00'	<b>4.0' long Sharp-Crested Vee/Trap Weir</b> Cv= 2.62 (C= 3.28)
#3	Discarded	331.00'	<b>15.000 in/hr Exfiltration over Surface area</b>

**Discarded OutFlow** Max=0.84 cfs @ 11.45 hrs HW=331.05' (Free Discharge)  
 ↳ **3=Exfiltration** (Exfiltration Controls 0.84 cfs)

**Primary OutFlow** Max=6.72 cfs @ 12.11 hrs HW=334.64' (Free Discharge)  
 ↳ **1=Culvert** (Passes 6.72 cfs of 20.48 cfs potential flow)  
 ↳ **2=Sharp-Crested Vee/Trap Weir** (Weir Controls 6.72 cfs @ 2.62 fps)

### Pond 9P: Infiltration Basin #2





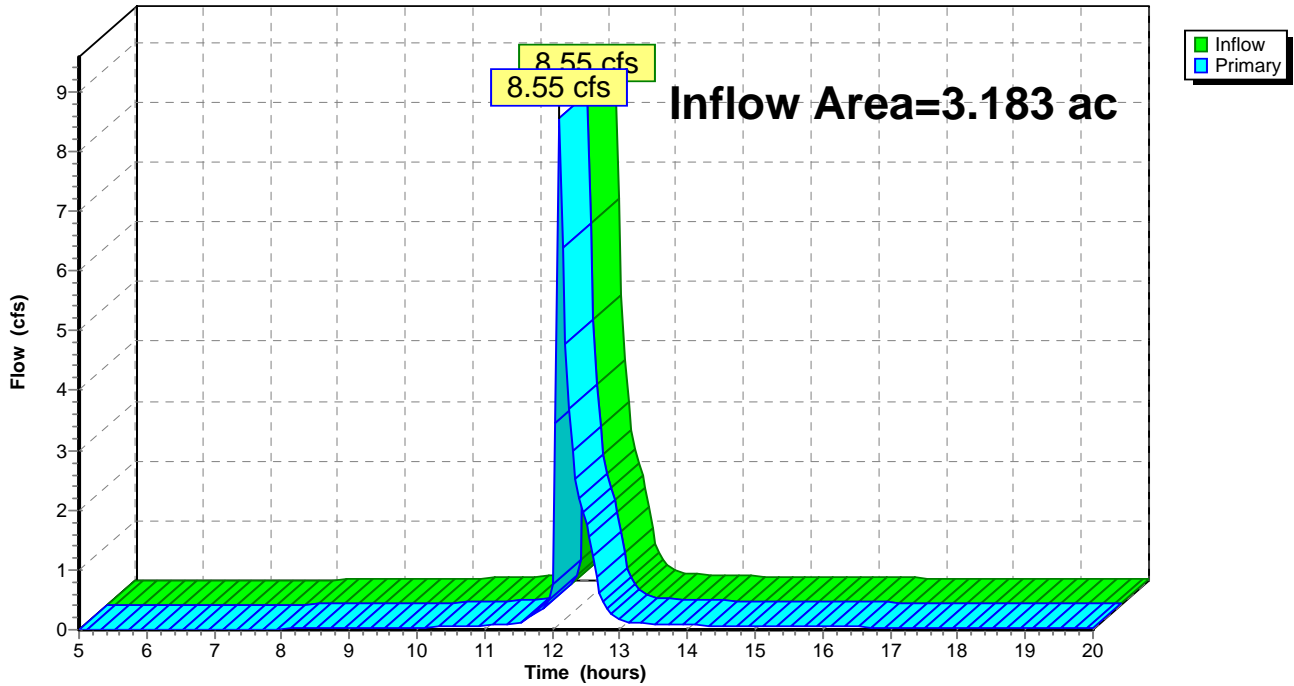
### Summary for Link 5L: DP#1

Inflow Area = 3.183 ac, 47.19% Impervious, Inflow Depth > 0.91" for 25-yr event  
Inflow = 8.55 cfs @ 12.11 hrs, Volume= 0.240 af  
Primary = 8.55 cfs @ 12.11 hrs, Volume= 0.240 af, Atten= 0%, Lag= 0.0 min

Primary outflow = Inflow, Time Span= 5.00-20.00 hrs, dt= 0.05 hrs

### Link 5L: DP#1

Hydrograph



**Summary for Subcatchment 3S: Post Area 1A**

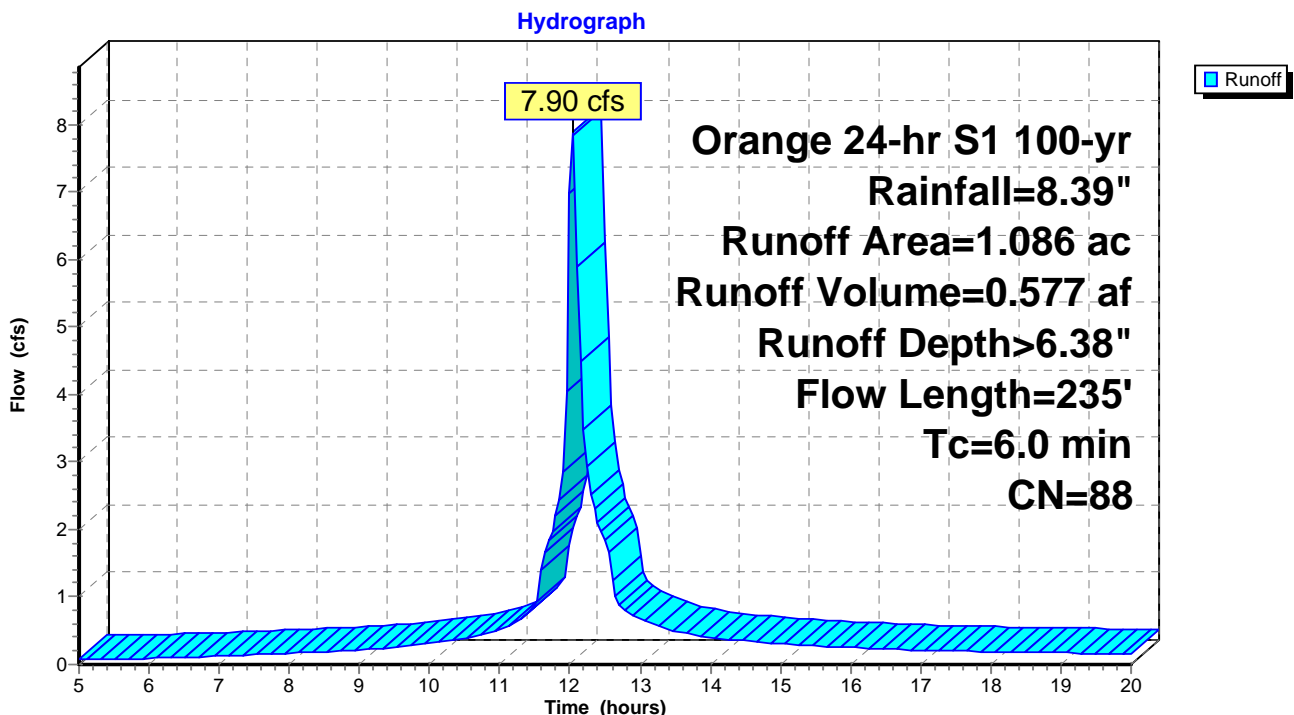
Runoff = 7.90 cfs @ 12.04 hrs, Volume= 0.577 af, Depth> 6.38"

Runoff by SCS TR-20 method, UH=SCS, Weighted-CN, Time Span= 5.00-20.00 hrs, dt= 0.05 hrs  
 Orange 24-hr S1 100-yr Rainfall=8.39"

Area (ac)	CN	Description
* 0.302	98	Proposed Pavement
* 0.107	98	Proposed Building
* 0.024	98	Proposed Sidewalk
0.236	80	>75% Grass cover, Good, HSG D
0.417	82	Woods/grass comb., Fair, HSG D
1.086	88	Weighted Average
0.653		60.13% Pervious Area
0.433		39.87% Impervious Area

Tc (min)	Length (feet)	Slope (ft/ft)	Velocity (ft/sec)	Capacity (cfs)	Description
0.6	50	0.0400	1.50		<b>Sheet Flow, Reach A-B</b> Smooth surfaces n= 0.011 P2= 2.90"
0.4	185	0.0190	8.19	14.48	<b>Pipe Channel, Rach B-C</b> 18.0" Round Area= 1.8 sf Perim= 4.7' r= 0.38' n= 0.013 Corrugated PE, smooth interior
5.0					<b>Direct Entry,</b>
6.0	235	Total			

**Subcatchment 3S: Post Area 1A**



**Summary for Subcatchment 4S: Post Area 1B**

Runoff = 13.30 cfs @ 12.04 hrs, Volume= 0.986 af, Depth> 6.67"

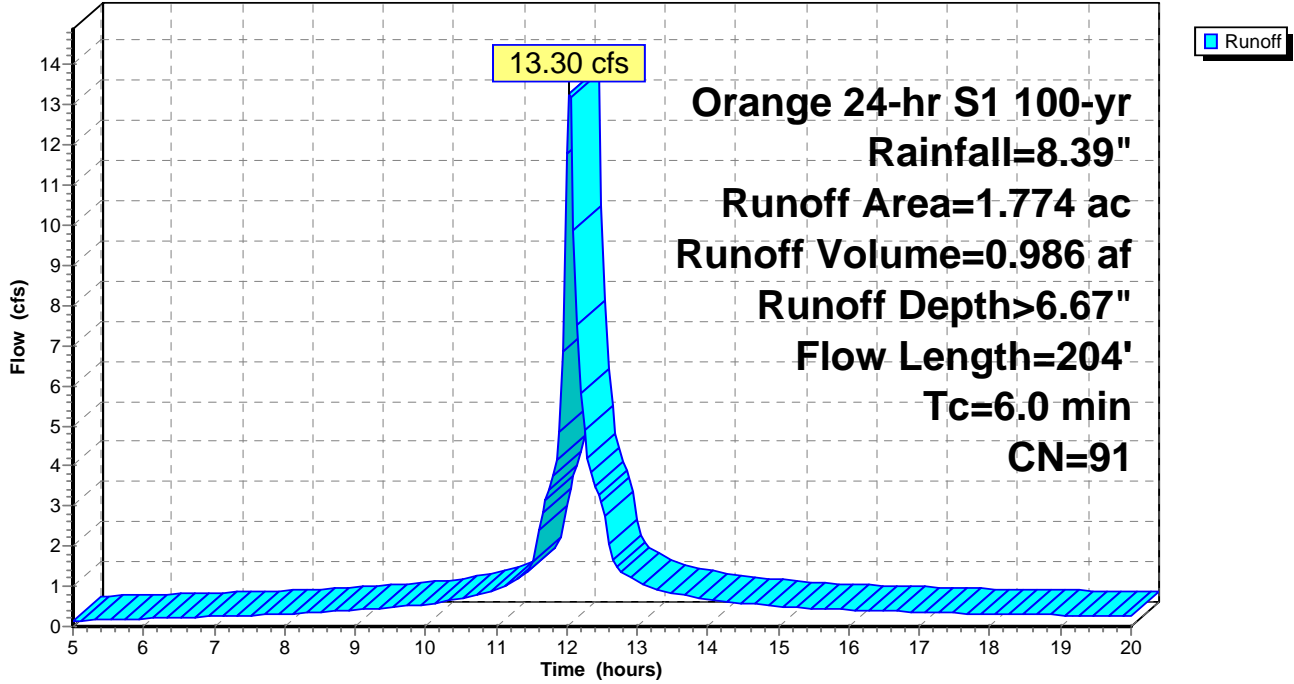
Runoff by SCS TR-20 method, UH=SCS, Weighted-CN, Time Span= 5.00-20.00 hrs, dt= 0.05 hrs  
 Orange 24-hr S1 100-yr Rainfall=8.39"

Area (ac)	CN	Description
* 0.798	98	Proposed Pavement
* 0.208	98	Proposed Building
* 0.031	98	Proposed Sidewalk
0.469	80	>75% Grass cover, Good, HSG D
0.268	82	Woods/grass comb., Fair, HSG D
1.774	91	Weighted Average
0.737		41.54% Pervious Area
1.037		58.46% Impervious Area

Tc (min)	Length (feet)	Slope (ft/ft)	Velocity (ft/sec)	Capacity (cfs)	Description
2.1	10	0.0800	0.08		<b>Sheet Flow, Reach A-B</b> Woods: Light underbrush n= 0.400 P2= 2.90"
0.1	30	0.3300	9.25		<b>Shallow Concentrated Flow, Reach B-C</b> Unpaved Kv= 16.1 fps
0.4	110	0.0500	4.54		<b>Shallow Concentrated Flow, Reach C-D</b> Paved Kv= 20.3 fps
0.2	54	0.0090	5.64	9.97	<b>Pipe Channel, Reach D-E</b> 18.0" Round Area= 1.8 sf Perim= 4.7' r= 0.38' n= 0.013 Corrugated PE, smooth interior
3.2					<b>Direct Entry,</b>
6.0	204	Total			

Subcatchment 4S: Post Area 1B

Hydrograph



**Summary for Subcatchment 6S: Post Area 1**

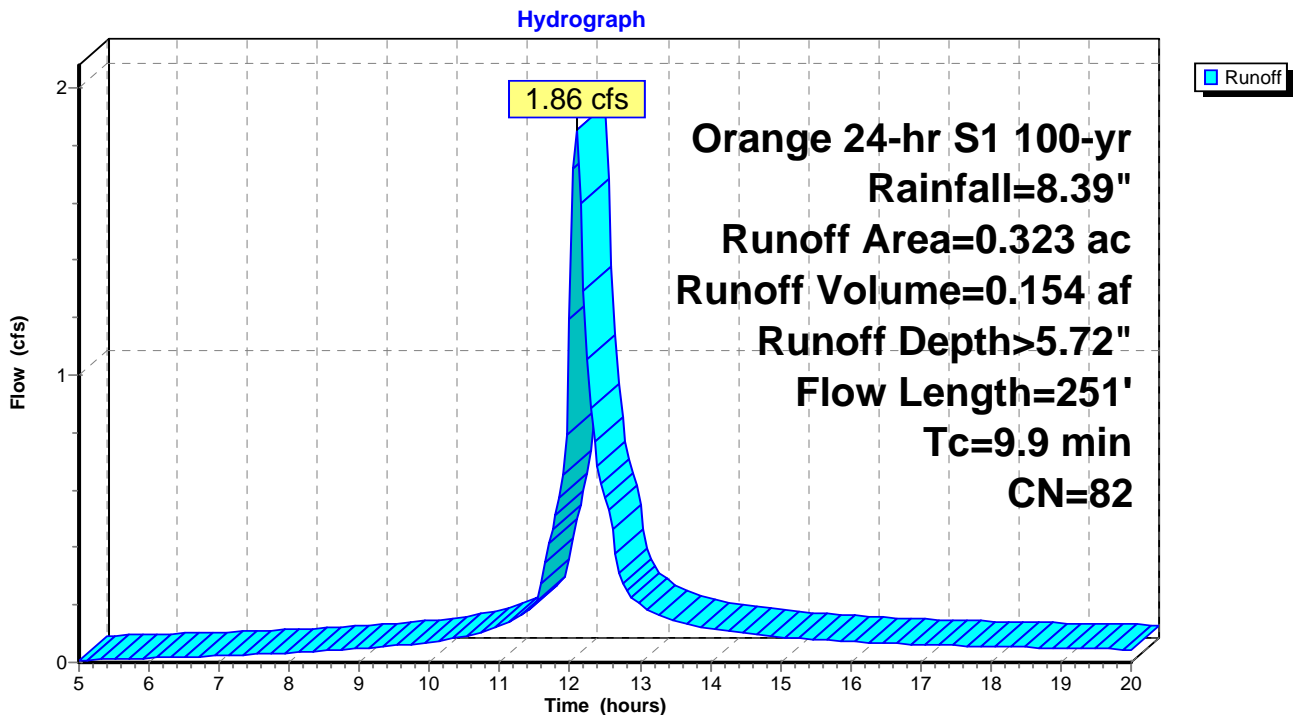
Runoff = 1.86 cfs @ 12.09 hrs, Volume= 0.154 af, Depth> 5.72"

Runoff by SCS TR-20 method, UH=SCS, Weighted-CN, Time Span= 5.00-20.00 hrs, dt= 0.05 hrs  
 Orange 24-hr S1 100-yr Rainfall=8.39"

Area (ac)	CN	Description
0.291	80	>75% Grass cover, Good, HSG D
* 0.032	98	Proposed Pavement
0.323	82	Weighted Average
0.291		90.09% Pervious Area
0.032		9.91% Impervious Area

Tc (min)	Length (feet)	Slope (ft/ft)	Velocity (ft/sec)	Capacity (cfs)	Description
7.3	96	0.0430	0.22		<b>Sheet Flow, Reach A-B</b> Grass: Short n= 0.150 P2= 2.90"
2.6	155	0.0004	0.98	0.77	<b>Pipe Channel, RCP_Round 12"</b> 12.0" Round Area= 0.8 sf Perim= 3.1' r= 0.25' n= 0.012 Concrete pipe, finished
9.9	251	Total			

**Subcatchment 6S: Post Area 1**



**Summary for Subcatchment 7S: Post Area 2**

Runoff = 0.30 cfs @ 12.05 hrs, Volume= 0.022 af, Depth> 5.51"

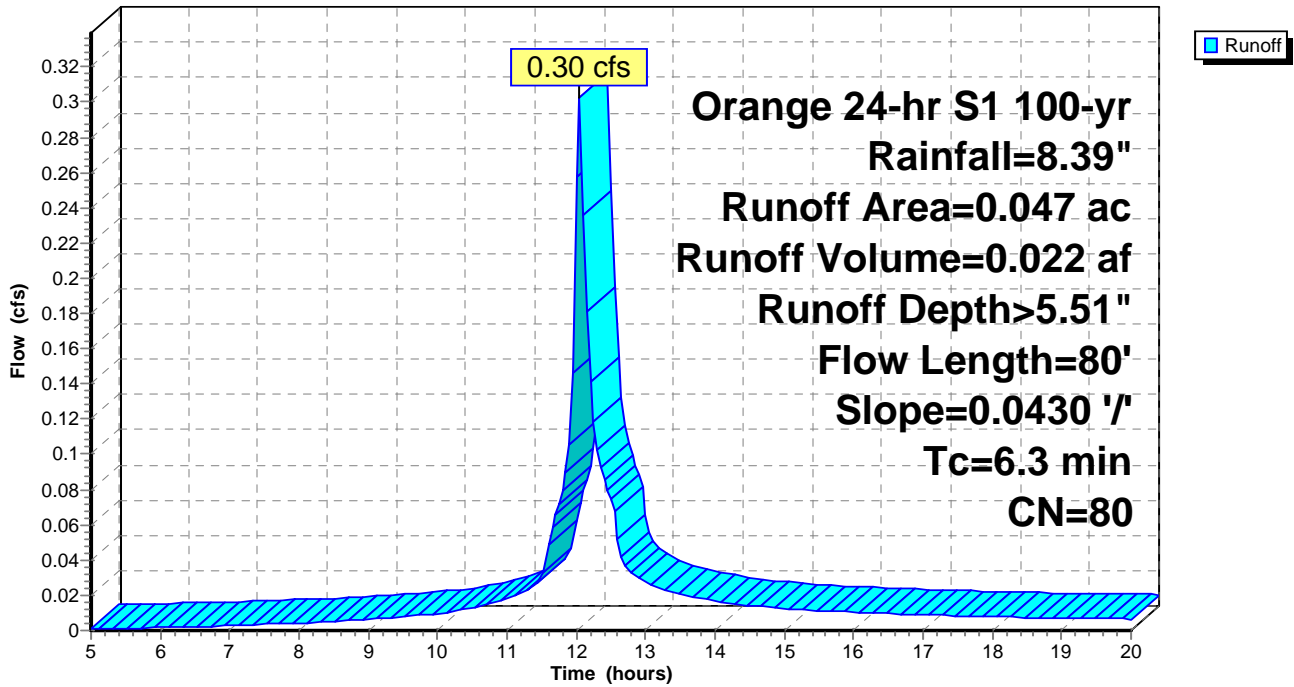
Runoff by SCS TR-20 method, UH=SCS, Weighted-CN, Time Span= 5.00-20.00 hrs, dt= 0.05 hrs  
 Orange 24-hr S1 100-yr Rainfall=8.39"

Area (ac)	CN	Description
0.047	80	>75% Grass cover, Good, HSG D
0.047		100.00% Pervious Area

Tc (min)	Length (feet)	Slope (ft/ft)	Velocity (ft/sec)	Capacity (cfs)	Description
6.3	80	0.0430	0.21		Sheet Flow, Reach A-B Grass: Short n= 0.150 P2= 2.90"

**Subcatchment 7S: Post Area 2**

Hydrograph



**Summary for Pond 8P: Infiltration Basin#1**

[82] Warning: Early inflow requires earlier time span

[93] Warning: Storage range exceeded by 0.02'

Inflow Area = 1.086 ac, 39.87% Impervious, Inflow Depth > 6.38" for 100-yr event  
 Inflow = 7.90 cfs @ 12.04 hrs, Volume= 0.577 af  
 Outflow = 5.31 cfs @ 12.16 hrs, Volume= 0.577 af, Atten= 33%, Lag= 7.3 min  
 Discarded = 0.87 cfs @ 11.55 hrs, Volume= 0.496 af  
 Primary = 4.45 cfs @ 12.16 hrs, Volume= 0.081 af

Routing by Stor-Ind method, Time Span= 5.00-20.00 hrs, dt= 0.05 hrs  
 Peak Elev= 334.24' @ 12.16 hrs Surf.Area= 2,500 sf Storage= 5,178 cf

Plug-Flow detention time= 29.4 min calculated for 0.575 af (100% of inflow)  
 Center-of-Mass det. time= 29.1 min ( 781.5 - 752.3 )

Volume	Invert	Avail.Storage	Storage Description
#1	330.20'	3,248 cf	<b>Custom Stage Data (Prismatic)</b> Listed below (Recalc) 10,050 cf Overall - 1,929 cf Embedded = 8,121 cf x 40.0% Voids
#2	331.22'	1,929 cf	<b>ADS_ StormTech SC-740 +Cap</b> x 42 Inside #1 Effective Size= 44.6"W x 30.0"H => 6.45 sf x 7.12'L = 45.9 cf Overall Size= 51.0"W x 30.0"H x 7.56'L with 0.44' Overlap 6 Rows of 7 Chambers
		5,178 cf	Total Available Storage

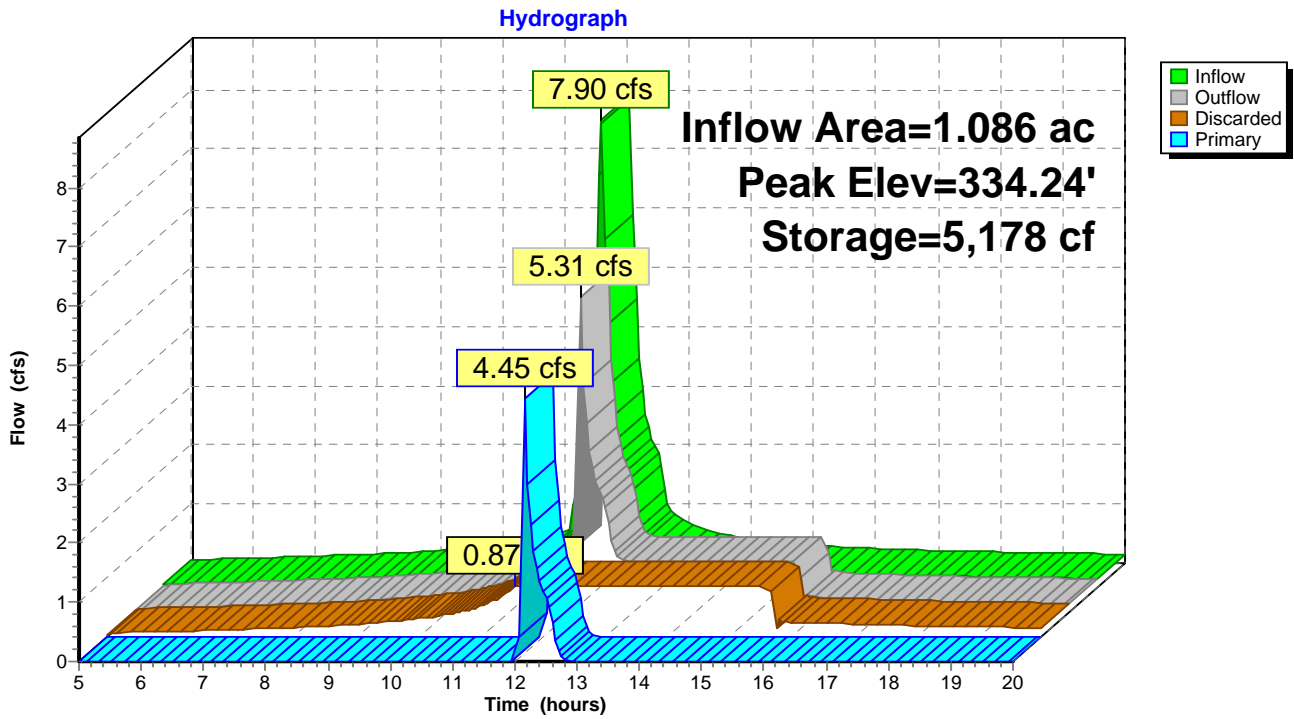
Elevation (feet)	Surf.Area (sq-ft)	Inc.Store (cubic-feet)	Cum.Store (cubic-feet)
330.20	2,500	0	0
334.22	2,500	10,050	10,050

Device	Routing	Invert	Outlet Devices
#1	Primary	328.10'	<b>18.0" Round Culvert</b> L= 30.0' CMP, square edge headwall, Ke= 0.500 Inlet / Outlet Invert= 328.10' / 326.90' S= 0.0400 '/' Cc= 0.900 n= 0.013 Corrugated PE, smooth interior, Flow Area= 1.77 sf
#2	Device 1	333.75'	<b>4.0' long Sharp-Crested Vee/Trap Weir</b> Cv= 2.62 (C= 3.28)
#3	Discarded	330.20'	<b>15.000 in/hr Exfiltration over Surface area</b>

**Discarded OutFlow** Max=0.87 cfs @ 11.55 hrs HW=330.25' (Free Discharge)  
 ↳ **3=Exfiltration** (Exfiltration Controls 0.87 cfs)

**Primary OutFlow** Max=4.01 cfs @ 12.16 hrs HW=334.20' (Free Discharge)  
 ↳ **1=Culvert** (Passes 4.01 cfs of 19.69 cfs potential flow)  
 ↳ **2=Sharp-Crested Vee/Trap Weir** (Weir Controls 4.01 cfs @ 2.21 fps)

### Pond 8P: Infiltration Basin#1





**Summary for Pond 9P: Infiltration Basin #2**

[82] Warning: Early inflow requires earlier time span

[88] Warning: Qout>Qin may require smaller dt or Finer Routing

Inflow Area = 1.774 ac, 58.46% Impervious, Inflow Depth > 6.67" for 100-yr event  
 Inflow = 13.30 cfs @ 12.04 hrs, Volume= 0.986 af  
 Outflow = 13.33 cfs @ 12.06 hrs, Volume= 0.986 af, Atten= 0%, Lag= 1.1 min  
 Discarded = 0.84 cfs @ 10.90 hrs, Volume= 0.674 af  
 Primary = 12.48 cfs @ 12.06 hrs, Volume= 0.312 af

Routing by Stor-Ind method, Time Span= 5.00-20.00 hrs, dt= 0.05 hrs  
 Peak Elev= 334.97' @ 12.06 hrs Surf.Area= 2,427 sf Storage= 5,507 cf

Plug-Flow detention time= 24.3 min calculated for 0.986 af (100% of inflow)  
 Center-of-Mass det. time= 24.1 min ( 770.2 - 746.1 )

Volume	Invert	Avail.Storage	Storage Description
#1	331.00'	3,266 cf	<b>Custom Stage Data (Prismatic)</b> Listed below (Recalc) 10,922 cf Overall - 2,756 cf Embedded = 8,165 cf x 40.0% Voids
#2	332.50'	2,756 cf	<b>ADS_ StormTech SC-740 +Cap</b> x 60 Inside #1 Effective Size= 44.6"W x 30.0"H => 6.45 sf x 7.12'L = 45.9 cf Overall Size= 51.0"W x 30.0"H x 7.56'L with 0.44' Overlap 6 Rows of 10 Chambers
		6,022 cf	Total Available Storage

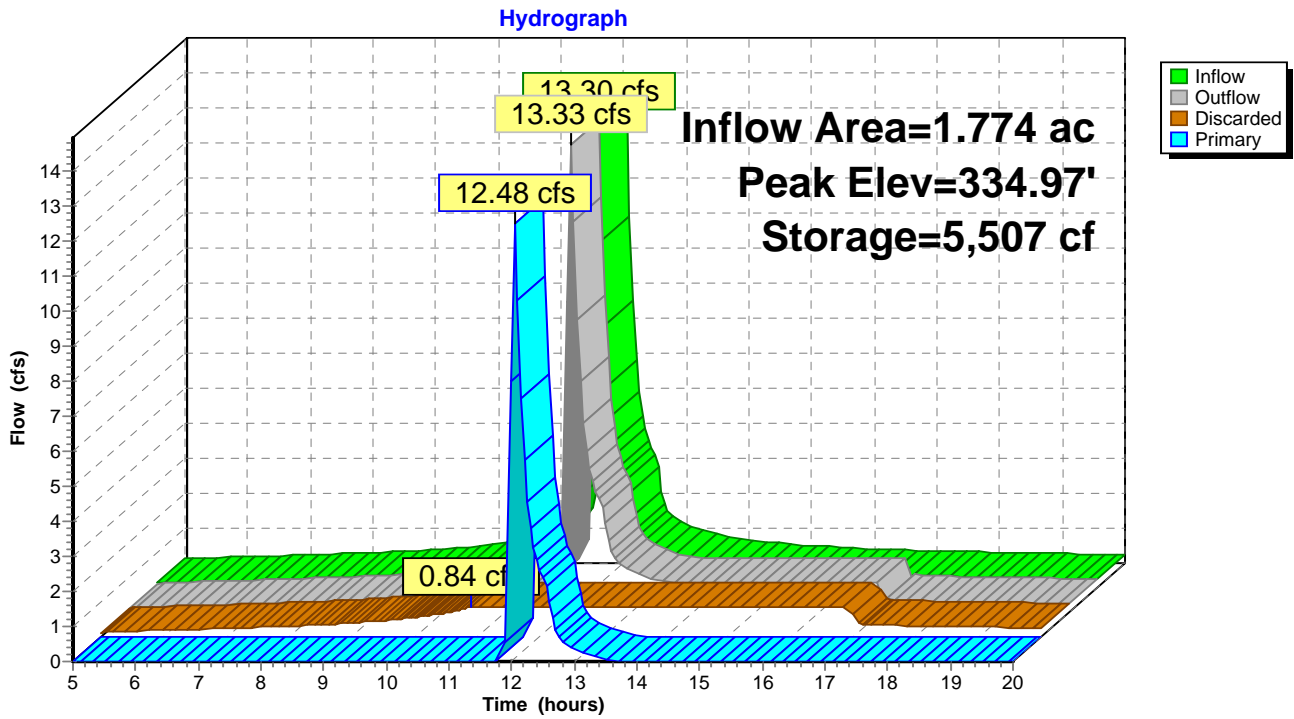
Elevation (feet)	Surf.Area (sq-ft)	Inc.Store (cubic-feet)	Cum.Store (cubic-feet)
331.00	2,427	0	0
335.50	2,427	10,922	10,922

Device	Routing	Invert	Outlet Devices
#1	Primary	328.10'	<b>18.0" Round Culvert</b> L= 30.0' CMP, square edge headwall, Ke= 0.500 Inlet / Outlet Invert= 328.10' / 326.90' S= 0.0400 '/' Cc= 0.900 n= 0.013 Corrugated PE, smooth interior, Flow Area= 1.77 sf
#2	Device 1	334.00'	<b>4.0' long Sharp-Crested Vee/Trap Weir</b> Cv= 2.62 (C= 3.28)
#3	Discarded	331.00'	<b>15.000 in/hr Exfiltration over Surface area</b>

**Discarded OutFlow** Max=0.84 cfs @ 10.90 hrs HW=331.05' (Free Discharge)  
 ↳ **3=Exfiltration** (Exfiltration Controls 0.84 cfs)

**Primary OutFlow** Max=12.01 cfs @ 12.06 hrs HW=334.94' (Free Discharge)  
 ↳ **1=Culvert** (Passes 12.01 cfs of 21.00 cfs potential flow)  
 ↳ **2=Sharp-Crested Vee/Trap Weir** (Weir Controls 12.01 cfs @ 3.18 fps)

### Pond 9P: Infiltration Basin #2



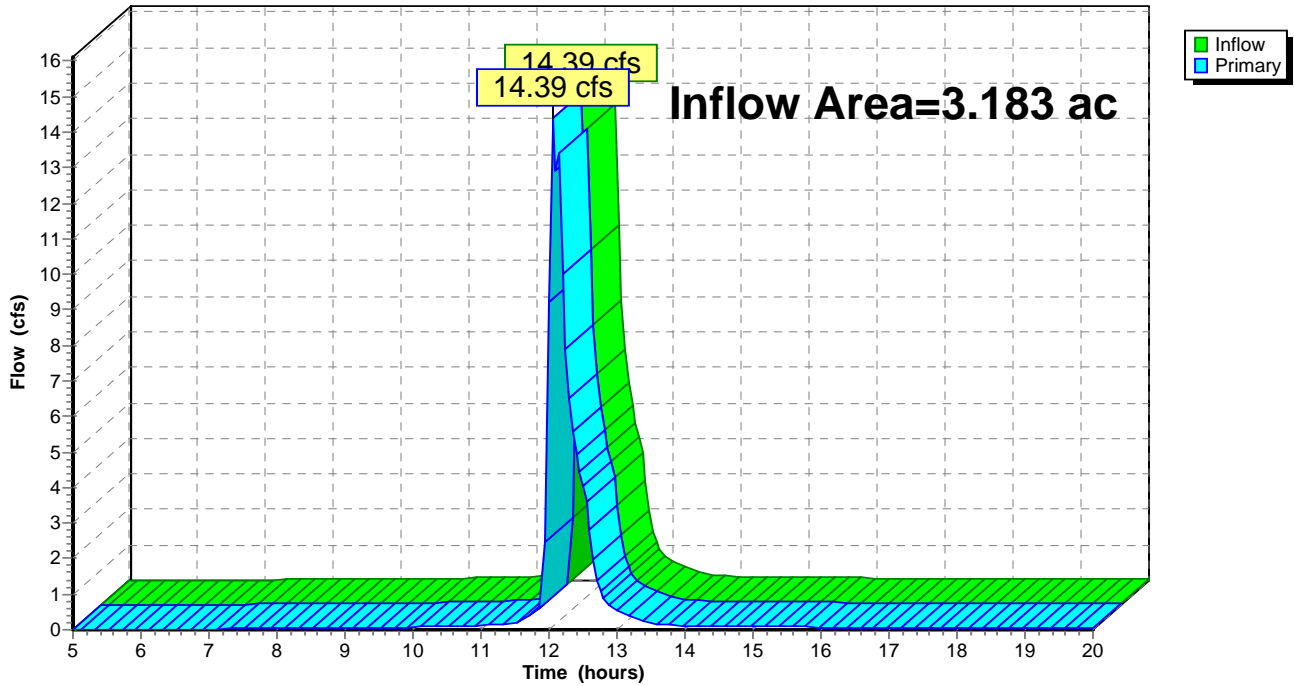
### Summary for Link 5L: DP#1

Inflow Area = 3.183 ac, 47.19% Impervious, Inflow Depth > 2.06" for 100-yr event  
Inflow = 14.39 cfs @ 12.07 hrs, Volume= 0.548 af  
Primary = 14.39 cfs @ 12.07 hrs, Volume= 0.548 af, Atten= 0%, Lag= 0.0 min

Primary outflow = Inflow, Time Span= 5.00-20.00 hrs, dt= 0.05 hrs

### Link 5L: DP#1

Hydrograph







## Appendix C

# Unified Sizing Criteria Calculations



## Water Quality Calculations Post-Area #1A

$$WQ_v = \frac{(P)(R_v)(A)}{12}$$

### Where:

- WQ<sub>v</sub> = Water Quality Volume (acre-feet)
- P = 90% Rainfall Event Number (See Figure D, Section 5.1)
- R<sub>v</sub> = 0.05 + 0.009(I), where I is percent impervious cover
- A = Contributing area (acres)

### Compute Impervious Cover, I:

Total Area of Drainage Sub-Area 1A = 1.08 Ac.

Total Impervious Area within Drainage Area #1A = 0.43 Ac

Percentage of Impervious Cover (I) = 39.8%

### Compute Runoff Coefficient, R<sub>v</sub>:

$$R_v = 0.05 + (0.009) (I)$$

$$R_v = 0.05 + (0.009) (39.8)$$

$$R_v = 0.40$$

### Compute Water Quality Volume, WQ<sub>v</sub>:

P = 1.1 (Using the 90% Rainfall Event Number from Figure D)

$$WQ_v = \frac{(1.1)(0.40)(1.08)}{12}$$

$$WQ_v = 0.040 \text{ ac-ft}$$

$$WQ_v = 1,760 \text{ ft}^3$$

## Water Quality Calculations Post-Area #1B

$$WQ_v = \frac{(P)(R_v)(A)}{12}$$

**Where:**

- WQ<sub>v</sub> = Water Quality Volume (acre-feet)
- P = 90% Rainfall Event Number (See Figure D, Section 5.1)
- R<sub>v</sub> = 0.05 + 0.009(I), where I is percent impervious cover
- A = Contributing area (acres)

**Compute Impervious Cover, I:**

Total Area of Drainage Sub-Area 1A = 1.77 Ac.

Total Impervious Area within Drainage Area #1A = 1.03 Ac

Percentage of Impervious Cover (I) = 58.4%

**Compute Runoff Coefficient, R<sub>v</sub>:**

$$R_v = 0.05 + (0.009) (I)$$

$$R_v = 0.05 + (0.009) (58.4)$$

$$R_v = 0.57$$

**Compute Water Quality Volume, WQ<sub>v</sub>:**

P = 1.1 (Using the 90% Rainfall Event Number from Figure D)

$$WQ_v = \frac{(1.1)(0.57)(1.77)}{12}$$

$$WQ_v = \mathbf{0.092 \text{ ac-ft}}$$

$$WQ_v = \mathbf{4,030 \text{ ft}^3}$$





## Appendix D

# SPDES General Permit for Stormwater Discharges from Construction Activity

**Permit No. GP-0-15-002**





Department of  
Environmental  
Conservation

NEW YORK STATE  
DEPARTMENT OF ENVIRONMENTAL CONSERVATION  
SPDES GENERAL PERMIT  
FOR STORMWATER DISCHARGES

From

**CONSTRUCTION ACTIVITY**

Permit No. GP-0-15-002

Issued Pursuant to Article 17, Titles 7, 8 and Article 70  
of the Environmental Conservation Law

Effective Date: January 29, 2015

Expiration Date: January 28, 2020

John J. Ferguson  
Chief Permit Administrator

  
Authorized Signature

1 / 12 / 15

Date

Address: NYS DEC  
Division of Environmental Permits  
625 Broadway, 4th Floor  
Albany, N.Y. 12233-1750

## PREFACE

Pursuant to Section 402 of the Clean Water Act (“CWA”), stormwater *discharges* from certain *construction activities* are unlawful unless they are authorized by a *National Pollutant Discharge Elimination System (“NPDES”)* permit or by a state permit program. New York’s *State Pollutant Discharge Elimination System (“SPDES”)* is a NPDES-approved program with permits issued in accordance with the *Environmental Conservation Law (“ECL”)*.

This general permit (“permit”) is issued pursuant to Article 17, Titles 7, 8 and Article 70 of the ECL. An *owner or operator* may obtain coverage under this permit by submitting a Notice of Intent (“NOI”) to the Department. Copies of this permit and the NOI for New York are available by calling (518) 402-8109 or at any New York State Department of Environmental Conservation (“the Department”) regional office (see Appendix G). They are also available on the Department’s website at:

<http://www.dec.ny.gov/>

An *owner or operator* of a *construction activity* that is eligible for coverage under this permit must obtain coverage prior to the *commencement of construction activity*. Activities that fit the definition of “*construction activity*”, as defined under 40 CFR 122.26(b)(14)(x), (15)(i), and (15)(ii), constitute construction of a point source and therefore, pursuant to Article 17-0505 of the ECL, the *owner or operator* must have coverage under a SPDES permit prior to *commencing construction activity*. They cannot wait until there is an actual *discharge* from the construction site to obtain permit coverage.

**\*Note: The italicized words/phrases within this permit are defined in Appendix A.**

**NEW YORK STATE DEPARTMENT OF ENVIRONMENTAL CONSERVATION**  
**SPDES GENERAL PERMIT FOR STORMWATER DISCHARGES**  
**FROM CONSTRUCTION ACTIVITIES**

Part I. PERMIT COVERAGE AND LIMITATIONS .....	1
A. Permit Application .....	1
B. Effluent Limitations Applicable to Discharges from Construction Activities .....	1
C. Post-construction Stormwater Management Practice Requirements .....	4
D. Maintaining Water Quality .....	8
E. Eligibility Under This General Permit.....	9
F. Activities Which Are Ineligible for Coverage Under This General Permit .....	9
Part II. OBTAINING PERMIT COVERAGE .....	12
A. Notice of Intent (NOI) Submittal .....	12
B. Permit Authorization.....	13
C. General Requirements For Owners or Operators With Permit Coverage .....	15
D. Permit Coverage for Discharges Authorized Under GP-0-10-001.....	17
E. Change of <i>Owner or Operator</i> .....	17
Part III. STORMWATER POLLUTION PREVENTION PLAN (SWPPP).....	18
A. General SWPPP Requirements .....	18
B. Required SWPPP Contents .....	20
C. Required SWPPP Components by Project Type.....	23
Part IV. INSPECTION AND MAINTENANCE REQUIREMENTS.....	24
A. General Construction Site Inspection and Maintenance Requirements .....	24
B. Contractor Maintenance Inspection Requirements .....	24
C. Qualified Inspector Inspection Requirements.....	24
Part V. TERMINATION OF PERMIT COVERAGE.....	28
A. Termination of Permit Coverage .....	28
Part VI. REPORTING AND RETENTION OF RECORDS.....	30
A. Record Retention .....	30
B. Addresses .....	30
Part VII. STANDARD PERMIT CONDITIONS.....	31
A. Duty to Comply.....	31
B. Continuation of the Expired General Permit.....	31
C. Enforcement.....	31
D. Need to Halt or Reduce Activity Not a Defense.....	31
E. Duty to Mitigate .....	32
F. Duty to Provide Information.....	32
G. Other Information .....	32
H. Signatory Requirements.....	32
I. Property Rights.....	34
J. Severability.....	34
K. Requirement to Obtain Coverage Under an Alternative Permit.....	34
L. Proper Operation and Maintenance .....	35
M. Inspection and Entry .....	35
N. Permit Actions.....	36
O. Definitions .....	36
P. Re-Opener Clause .....	36

Q. Penalties for Falsification of Forms and Reports.....	36
R. Other Permits.....	36
APPENDIX A.....	37
APPENDIX B.....	44
APPENDIX C.....	46
APPENDIX D.....	52
APPENDIX E.....	53
APPENDIX F.....	55

(Part I)

I.

## Part I. PERMIT COVERAGE AND LIMITATIONS

### A. Permit Application

This permit authorizes stormwater *discharges to surface waters of the State* from the following *construction activities* identified within 40 CFR Parts 122.26(b)(14)(x), 122.26(b)(15)(i) and 122.26(b)(15)(ii), provided all of the eligibility provisions of this permit are met:

1. *Construction activities* involving soil disturbances of one (1) or more acres; including disturbances of less than one acre that are part of a *larger common plan of development or sale* that will ultimately disturb one or more acres of land; excluding *routine maintenance activity* that is performed to maintain the original line and grade, hydraulic capacity or original purpose of a facility;
2. *Construction activities* involving soil disturbances of less than one (1) acre where the Department has determined that a *SPDES* permit is required for stormwater *discharges* based on the potential for contribution to a violation of a *water quality standard* or for significant contribution of *pollutants* to *surface waters of the State*.
3. *Construction activities* located in the watershed(s) identified in Appendix D that involve soil disturbances between five thousand (5,000) square feet and one (1) acre of land.

### B. Effluent Limitations Applicable to Discharges from Construction Activities

*Discharges* authorized by this permit must achieve, at a minimum, the effluent limitations in Part I.B.1. (a) – (f) of this permit. These limitations represent the degree of effluent reduction attainable by the application of best practicable technology currently available.

1. Erosion and Sediment Control Requirements - The *owner or operator* must select, design, install, implement and maintain control measures to *minimize* the *discharge of pollutants* and prevent a violation of the *water quality standards*. The selection, design, installation, implementation, and maintenance of these control measures must meet the non-numeric effluent limitations in Part I.B.1.(a) – (f) of this permit and be in accordance with the New York State Standards and Specifications for Erosion and Sediment Control, dated August 2005, using sound engineering judgment. Where control measures are not designed in conformance with the design criteria included in the technical standard, the *owner or operator* must include in the Stormwater Pollution Prevention Plan (“SWPPP”) the reason(s) for the deviation or alternative design and provide information

(Part I.B.1)

which demonstrates that the deviation or alternative design is *equivalent* to the technical standard.

a. **Erosion and Sediment Controls.** Design, install and maintain effective erosion and sediment controls to *minimize* the *discharge* of *pollutants* and prevent a violation of the *water quality standards*. At a minimum, such controls must be designed, installed and maintained to:

- (i) *Minimize* soil erosion through application of runoff control and soil stabilization control measure to *minimize pollutant discharges*;
- (ii) Control stormwater *discharges* to *minimize* channel and streambank erosion and scour in the immediate vicinity of the *discharge* points;
- (iii) *Minimize* the amount of soil exposed during *construction activity*;
- (iv) *Minimize* the disturbance of *steep slopes*;
- (v) *Minimize* sediment *discharges* from the site;
- (vi) Provide and maintain natural buffers around surface waters, direct stormwater to vegetated areas and maximize stormwater infiltration to reduce *pollutant discharges*, unless *infeasible*;
- (vii) *Minimize* soil compaction. Minimizing soil compaction is not required where the intended function of a specific area of the site dictates that it be compacted; and
- (viii) Unless *infeasible*, preserve a sufficient amount of topsoil to complete soil restoration and establish a uniform, dense vegetative cover.

b. **Soil Stabilization.** In areas where soil disturbance activity has temporarily or permanently ceased, the application of soil stabilization measures must be initiated by the end of the next business day and completed within fourteen (14) days from the date the current soil disturbance activity ceased. For construction sites that *directly discharge* to one of the 303(d) segments listed in Appendix E or is located in one of the watersheds listed in Appendix C, the application of soil stabilization measures must be initiated by the end of the next business day and completed within seven (7) days from the date the current soil disturbance activity ceased. See Appendix A for definition of *Temporarily Ceased*.

c. **Dewatering.** *Discharges* from dewatering activities, including *discharges*



(Part I.B.1.c)

from dewatering of trenches and excavations, must be managed by appropriate control measures.

d. **Pollution Prevention Measures.** Design, install, implement, and maintain effective pollution prevention measures to *minimize* the *discharge* of *pollutants* and prevent a violation of the *water quality standards*. At a minimum, such measures must be designed, installed, implemented and maintained to:

- (i) *Minimize* the *discharge* of *pollutants* from equipment and vehicle washing, wheel wash water, and other wash waters. This applies to washing operations that use clean water only. Soaps, detergents and solvents cannot be used;
- (ii) *Minimize* the exposure of building materials, building products, construction wastes, trash, landscape materials, fertilizers, pesticides, herbicides, detergents, sanitary waste and other materials present on the site to precipitation and to stormwater. Minimization of exposure is not required in cases where the exposure to precipitation and to stormwater will not result in a *discharge* of *pollutants*, or where exposure of a specific material or product poses little risk of stormwater contamination (such as final products and materials intended for outdoor use) ; and
- (iii) Prevent the *discharge* of *pollutants* from spills and leaks and implement chemical spill and leak prevention and response procedures.

e. **Prohibited Discharges.** The following *discharges* are prohibited:

- (i) Wastewater from washout of concrete;
- (ii) Wastewater from washout and cleanout of stucco, paint, form release oils, curing compounds and other construction materials;
- (iii) Fuels, oils, or other *pollutants* used in vehicle and equipment operation and maintenance;
- (iv) Soaps or solvents used in vehicle and equipment washing; and
- (v) Toxic or hazardous substances from a spill or other release.

f. **Surface Outlets.** When discharging from basins and impoundments, the outlets shall be designed, constructed and maintained in such a manner that sediment does not leave the basin or impoundment and that erosion

(Part I.B.1.f)

at or below the outlet does not occur.

### **C. Post-construction Stormwater Management Practice Requirements**

1. The *owner or operator* of a *construction activity* that requires post-construction stormwater management practices pursuant to Part III.C. of this permit must select, design, install, and maintain the practices to meet the *performance criteria* in the New York State Stormwater Management Design Manual (“Design Manual”), dated January 2015, using sound engineering judgment. Where post-construction stormwater management practices (“SMPs”) are not designed in conformance with the *performance criteria* in the Design Manual, the *owner or operator* must include in the SWPPP the reason(s) for the deviation or alternative design and provide information which demonstrates that the deviation or alternative design is *equivalent* to the technical standard.
2. The *owner or operator* of a *construction activity* that requires post-construction stormwater management practices pursuant to Part III.C. of this permit must design the practices to meet the applicable *sizing criteria* in Part I.C.2.a., b., c. or d. of this permit.

#### **a. Sizing Criteria for New Development**

- (i) Runoff Reduction Volume (“RRv”): Reduce the total Water Quality Volume (“WQv”) by application of RR techniques and standard SMPs with RRv capacity. The total WQv shall be calculated in accordance with the criteria in Section 4.2 of the Design Manual.
- (ii) Minimum RRv and Treatment of Remaining Total WQv: *Construction activities* that cannot meet the criteria in Part I.C.2.a.(i) of this permit due to *site limitations* shall direct runoff from all newly constructed *impervious areas* to a RR technique or standard SMP with RRv capacity unless *infeasible*. The specific *site limitations* that prevent the reduction of 100% of the WQv shall be documented in the SWPPP. For each *impervious area* that is not directed to a RR technique or standard SMP with RRv capacity, the SWPPP must include documentation which demonstrates that all options were considered and for each option explains why it is considered *infeasible*.

**In no case shall the runoff reduction achieved from the newly constructed *impervious areas* be less than the Minimum RRv as calculated using the criteria in Section 4.3 of the Design Manual.** The remaining portion of the total WQv

(Part I.C.2.a.ii)

that cannot be reduced shall be treated by application of standard SMPs.

- (iii) Channel Protection Volume (“Cpv”): Provide 24 hour extended detention of the post-developed 1-year, 24-hour storm event; remaining after runoff reduction. The Cpv requirement does not apply when:
  - (1) Reduction of the entire Cpv is achieved by application of runoff reduction techniques or infiltration systems, or
  - (2) The site *discharges* directly to tidal waters, or fifth order or larger streams.
- (iv) Overbank Flood Control Criteria (“Qp”): Requires storage to attenuate the post-development 10-year, 24-hour peak *discharge* rate (Qp) to predevelopment rates. The Qp requirement does not apply when:
  - (1) the site *discharges* directly to tidal waters or fifth order or larger streams, or
  - (2) A downstream analysis reveals that overbank control is not required.
- (v) Extreme Flood Control Criteria (“Qf”): Requires storage to attenuate the post-development 100-year, 24-hour peak *discharge* rate (Qf) to predevelopment rates. The Qf requirement does not apply when:
  - (1) the site *discharges* directly to tidal waters or fifth order or larger streams, or
  - (2) A downstream analysis reveals that overbank control is not required.

**b. Sizing Criteria for New Development in Enhanced Phosphorus Removal Watershed**

- (i) Runoff Reduction Volume (RRv): Reduce the total Water Quality Volume (WQv) by application of RR techniques and standard SMPs with RRv capacity. The total WQv is the runoff volume from the 1-year, 24 hour design storm over the post-developed watershed and shall be calculated in accordance with the criteria in Section 10.3 of the Design Manual.
- (ii) Minimum RRv and Treatment of Remaining Total WQv: *Construction activities* that cannot meet the criteria in Part I.C.2.b.(i) of this permit due to *site limitations* shall direct runoff from all newly constructed *impervious areas* to a RR technique or

(Part I.C.2.b.ii)

standard SMP with RRv capacity unless *infeasible*. The specific *site limitations* that prevent the reduction of 100% of the WQv shall be documented in the SWPPP. For each *impervious area* that is not directed to a RR technique or standard SMP with RRv capacity, the SWPPP must include documentation which demonstrates that all options were considered and for each option explains why it is considered *infeasible*.

**In no case shall the runoff reduction achieved from the newly constructed *impervious areas* be less than the Minimum RRv as calculated using the criteria in Section 10.3 of the Design Manual.** The remaining portion of the total WQv that cannot be reduced shall be treated by application of standard SMPs.

- (iii) Channel Protection Volume (Cpv): Provide 24 hour extended detention of the post-developed 1-year, 24-hour storm event; remaining after runoff reduction. The Cpv requirement does not apply when:
  - (1) Reduction of the entire Cpv is achieved by application of runoff reduction techniques or infiltration systems, or
  - (2) The site *discharges* directly to tidal waters, or fifth order or larger streams.
- (iv) Overbank Flood Control Criteria (Qp): Requires storage to attenuate the post-development 10-year, 24-hour peak *discharge* rate (Qp) to predevelopment rates. The Qp requirement does not apply when:
  - (1) the site *discharges* directly to tidal waters or fifth order or larger streams, or
  - (2) A downstream analysis reveals that overbank control is not required.
- (v) Extreme Flood Control Criteria (Qf): Requires storage to attenuate the post-development 100-year, 24-hour peak *discharge* rate (Qf) to predevelopment rates. The Qf requirement does not apply when:
  - (1) the site *discharges* directly to tidal waters or fifth order or larger streams, or
  - (2) A downstream analysis reveals that overbank control is not required.

**c. Sizing Criteria for Redevelopment Activity**

(Part I.C.2.c.i)

- (i) Water Quality Volume (WQv): The WQv treatment objective for *redevelopment activity* shall be addressed by one of the following options. *Redevelopment activities* located in an Enhanced Phosphorus Removal Watershed (see Part III.B.3. and Appendix C of this permit) shall calculate the WQv in accordance with Section 10.3 of the Design Manual. All other *redevelopment activities* shall calculate the WQv in accordance with Section 4.2 of the Design Manual.
- (1) Reduce the existing *impervious cover* by a minimum of 25% of the total disturbed, *impervious area*. The Soil Restoration criteria in Section 5.1.6 of the Design Manual must be applied to all newly created pervious areas, or
  - (2) Capture and treat a minimum of 25% of the WQv from the disturbed, *impervious area* by the application of standard SMPs; or reduce 25% of the WQv from the disturbed, *impervious area* by the application of RR techniques or standard SMPs with RRv capacity., or
  - (3) Capture and treat a minimum of 75% of the WQv from the disturbed, *impervious area* as well as any additional runoff from tributary areas by application of the alternative practices discussed in Sections 9.3 and 9.4 of the Design Manual., or
  - (4) Application of a combination of 1, 2 and 3 above that provide a weighted average of at least two of the above methods. Application of this method shall be in accordance with the criteria in Section 9.2.1(B) (IV) of the Design Manual.

If there is an existing post-construction stormwater management practice located on the site that captures and treats runoff from the *impervious area* that is being disturbed, the WQv treatment option selected must, at a minimum, provide treatment equal to the treatment that was being provided by the existing practice(s) if that treatment is greater than the treatment required by options 1 – 4 above.

- (ii) Channel Protection Volume (Cpv): Not required if there are no changes to hydrology that increase the *discharge* rate from the project site.
- (iii) Overbank Flood Control Criteria (Qp): Not required if there are no changes to hydrology that increase the *discharge* rate from the project site.

(Part I.C.2.c.iv)

- (iv) Extreme Flood Control Criteria (Qf): Not required if there are no changes to hydrology that increase the *discharge* rate from the project site.

**d. Sizing Criteria for Combination of Redevelopment Activity and New Development**

Construction projects that include both *New Development* and *Redevelopment Activity* shall provide post-construction stormwater management controls that meet the *sizing criteria* calculated as an aggregate of the *Sizing Criteria* in Part I.C.2.a. or b. of this permit for the *New Development* portion of the project and Part I.C.2.c of this permit for *Redevelopment Activity* portion of the project.

**D. Maintaining Water Quality**

The Department expects that compliance with the conditions of this permit will control *discharges* necessary to meet applicable *water quality standards*. It shall be a violation of the *ECL* for any discharge to either cause or contribute to a violation of *water quality standards* as contained in Parts 700 through 705 of Title 6 of the Official Compilation of Codes, Rules and Regulations of the State of New York, such as:

1. There shall be no increase in turbidity that will cause a substantial visible contrast to natural conditions;
2. There shall be no increase in suspended, colloidal or settleable solids that will cause deposition or impair the waters for their best usages; and
3. There shall be no residue from oil and floating substances, nor visible oil film, nor globules of grease.

If there is evidence indicating that the stormwater *discharges* authorized by this permit are causing, have the reasonable potential to cause, or are contributing to a violation of the *water quality standards*; the *owner or operator* must take appropriate corrective action in accordance with Part IV.C.5. of this general permit and document in accordance with Part IV.C.4. of this general permit. To address the *water quality standard* violation the *owner or operator* may need to provide additional information, include and implement appropriate controls in the SWPPP to correct the problem, or obtain an individual SPDES permit.

If there is evidence indicating that despite compliance with the terms and conditions of this general permit it is demonstrated that the stormwater *discharges* authorized by this permit are causing or contributing to a violation of *water quality standards*, or

(Part I.D)

if the Department determines that a modification of the permit is necessary to prevent a violation of *water quality standards*, the authorized *discharges* will no longer be eligible for coverage under this permit. The Department may require the *owner or operator* to obtain an individual SPDES permit to continue discharging.

#### **E. Eligibility Under This General Permit**

1. This permit may authorize all *discharges* of stormwater from *construction activity to surface waters of the State* and *groundwaters* except for ineligible *discharges* identified under subparagraph F. of this Part.
2. Except for non-stormwater *discharges* explicitly listed in the next paragraph, this permit only authorizes stormwater *discharges* from *construction activities*.
3. Notwithstanding paragraphs E.1 and E.2 above, the following non-stormwater *discharges* may be authorized by this permit: *discharges* from firefighting activities; fire hydrant flushings; waters to which cleansers or other components have not been added that are used to wash vehicles or control dust in accordance with the SWPPP, routine external building washdown which does not use detergents; pavement washwaters where spills or leaks of toxic or hazardous materials have not occurred (unless all spilled material has been removed) and where detergents are not used; air conditioning condensate; uncontaminated *groundwater* or spring water; uncontaminated *discharges* from construction site de-watering operations; and foundation or footing drains where flows are not contaminated with process materials such as solvents. For those entities required to obtain coverage under this permit, and who *discharge* as noted in this paragraph, and with the exception of flows from firefighting activities, these *discharges* must be identified in the SWPPP. Under all circumstances, the *owner or operator* must still comply with *water quality standards* in Part I.D of this permit.
4. The *owner or operator* must maintain permit eligibility to *discharge* under this permit. Any *discharges* that are not compliant with the eligibility conditions of this permit are not authorized by the permit and the *owner or operator* must either apply for a separate permit to cover those ineligible *discharges* or take steps necessary to make the *discharge* eligible for coverage.

#### **F. Activities Which Are Ineligible for Coverage Under This General Permit**

All of the following are **not** authorized by this permit:

(Part I.F)

1. *Discharges after construction activities* have been completed and the site has undergone *final stabilization*;
2. *Discharges* that are mixed with sources of non-stormwater other than those expressly authorized under subsection E.3. of this Part and identified in the SWPPP required by this permit;
3. *Discharges* that are required to obtain an individual SPDES permit or another SPDES general permit pursuant to Part VII.K. of this permit;
4. *Construction activities* or *discharges from construction activities* that may adversely affect an endangered or threatened species unless the *owner or operator* has obtained a permit issued pursuant to 6 NYCRR Part 182 for the project or the Department has issued a letter of non-jurisdiction for the project. All documentation necessary to demonstrate eligibility shall be maintained on site in accordance with Part II.C.2 of this permit.
5. *Discharges* which either cause or contribute to a violation of *water quality standards* adopted pursuant to the *ECL* and its accompanying regulations;
6. *Construction activities* for residential, commercial and institutional projects:
  - a. Where the *discharges* from the *construction activities* are tributary to waters of the state classified as AA or AA-s; and
  - b. Which disturb one or more acres of land with no existing *impervious cover*; and
  - c. Which are undertaken on land with a Soil Slope Phase that is identified as an E or F, or the map unit name is inclusive of 25% or greater slope, on the United States Department of Agriculture (“USDA”) Soil Survey for the County where the disturbance will occur.
7. *Construction activities* for linear transportation projects and linear utility projects:
  - a. Where the *discharges* from the *construction activities* are tributary to waters of the state classified as AA or AA-s; and
  - b. Which disturb two or more acres of land with no existing *impervious cover*; and
  - c. Which are undertaken on land with a Soil Slope Phase that is identified as an E or F, or the map unit name is inclusive of 25% or greater slope, on the USDA Soil Survey for the County where the disturbance will occur.



(Part I.F.8)

8. *Construction activities* that have the potential to affect an *historic property*, unless there is documentation that such impacts have been resolved. The following documentation necessary to demonstrate eligibility with this requirement shall be maintained on site in accordance with Part II.C.2 of this permit and made available to the Department in accordance with Part VII.F of this permit:
- a. Documentation that the *construction activity* is not within an archeologically sensitive area indicated on the sensitivity map, and that the *construction activity* is not located on or immediately adjacent to a property listed or determined to be eligible for listing on the National or State Registers of Historic Places, and that there is no new permanent building on the construction site within the following distances from a building, structure, or object that is more than 50 years old, or if there is such a new permanent building on the construction site within those parameters that NYS Office of Parks, Recreation and Historic Preservation (OPRHP), a Historic Preservation Commission of a Certified Local Government, or a qualified preservation professional has determined that the building, structure, or object more than 50 years old is not historically/archeologically significant.
    - 1-5 acres of disturbance - 20 feet
    - 5-20 acres of disturbance - 50 feet
    - 20+ acres of disturbance - 100 feet, or
  - b. DEC consultation form sent to OPRHP, and copied to the NYS DEC Agency Historic Preservation Officer (APO), and
    - (i) the State Environmental Quality Review (SEQR) Environmental Assessment Form (EAF) with a negative declaration or the Findings Statement, with documentation of OPRHP's agreement with the resolution; or
    - (ii) documentation from OPRHP that the *construction activity* will result in No Impact; or
    - (iii) documentation from OPRHP providing a determination of No Adverse Impact; or
    - (iv) a Letter of Resolution signed by the owner/operator, OPRHP and the DEC APO which allows for this *construction activity* to be eligible for coverage under the general permit in terms of the State Historic Preservation Act (SHPA); or
  - c. Documentation of satisfactory compliance with Section 106 of the National Historic Preservation Act for a coterminous project area:
    - (i) No Affect
    - (ii) No Adverse Affect

(Part I.F.8.c.iii)

(iii) Executed Memorandum of Agreement, or

d. Documentation that:

(i) SHPA Section 14.09 has been completed by NYS DEC or another state agency.

9. *Discharges from construction activities* that are subject to an existing SPDES individual or general permit where a SPDES permit for *construction activity* has been terminated or denied; or where the *owner or operator* has failed to renew an expired individual permit.

## II. Part II. OBTAINING PERMIT COVERAGE

### A. Notice of Intent (NOI) Submittal

1. An *owner or operator* of a *construction activity* that is not subject to the requirements of a *regulated, traditional land use control MS4* must first prepare a SWPPP in accordance with all applicable requirements of this permit and then submit a completed NOI form to the Department in order to be authorized to *discharge* under this permit. An *owner or operator* shall use either the electronic (eNOI) or paper version of the NOI that the Department prepared. Both versions of the NOI are located on the Department's website (<http://www.dec.ny.gov/>). The paper version of the NOI shall be signed in accordance with Part VII.H. of this permit and submitted to the following address.

**NOTICE OF INTENT  
NYS DEC, Bureau of Water Permits  
625 Broadway, 4<sup>th</sup> Floor  
Albany, New York 12233-3505**

2. An *owner or operator* of a *construction activity* that is subject to the requirements of a *regulated, traditional land use control MS4* must first prepare a SWPPP in accordance with all applicable requirements of this permit and then have its SWPPP reviewed and accepted by the *regulated, traditional land use control MS4* prior to submitting the NOI to the Department. The *owner or operator* shall have the "MS4 SWPPP Acceptance" form signed in accordance with Part VII.H., and then submit that form along with a completed NOI to the Department. An *owner or operator* shall use either the electronic (eNOI) or paper version of the NOI.

The paper version of the NOI shall be signed in accordance with Part VII.H. of this permit and submitted to the address in Part II.A.1.

(Part II.A.2)

The requirement for an *owner or operator* to have its SWPPP reviewed and accepted by the *MS4* prior to submitting the NOI to the Department does not apply to an *owner or operator* that is obtaining permit coverage in accordance with the requirements in Part II.E. (*Change of Owner or Operator*) or where the *owner or operator* of the *construction activity* is the *regulated, traditional land use control MS4*.

3. The *owner or operator* shall have the SWPPP preparer sign the “SWPPP Preparer Certification” statement on the NOI prior to submitting the form to the Department.
4. As of the date the NOI is submitted to the Department, the *owner or operator* shall make the NOI and SWPPP available for review and copying in accordance with the requirements in Part VII.F. of this permit.

## **B. Permit Authorization**

1. An *owner or operator* shall not *commence construction activity* until their authorization to *discharge* under this permit goes into effect.
2. Authorization to *discharge* under this permit will be effective when the *owner or operator* has satisfied all of the following criteria:
  - a. project review pursuant to the State Environmental Quality Review Act (“SEQRA”) have been satisfied, when SEQRA is applicable. See the Department’s website (<http://www.dec.ny.gov/>) for more information,
  - b. where required, all necessary Department permits subject to the *Uniform Procedures Act (“UPA”)* (see 6 NYCRR Part 621) have been obtained, unless otherwise notified by the Department pursuant to 6 NYCRR 621.3(a)(4). *Owners or operators of construction activities* that are required to obtain *UPA* permits must submit a preliminary SWPPP to the appropriate DEC Permit Administrator at the Regional Office listed in Appendix F at the time all other necessary *UPA* permit applications are submitted. The preliminary SWPPP must include sufficient information to demonstrate that the *construction activity* qualifies for authorization under this permit,
  - c. the final SWPPP has been prepared, and
  - d. a complete NOI has been submitted to the Department in accordance with the requirements of this permit.
3. An *owner or operator* that has satisfied the requirements of Part II.B.2 above

(Part II.B.3)

will be authorized to *discharge* stormwater from their *construction activity* in accordance with the following schedule:

a. For *construction activities* that are not subject to the requirements of a *regulated, traditional land use control MS4*:

(i) Five (5) business days from the date the Department receives a complete electronic version of the NOI (eNOI) for *construction activities* with a SWPPP that has been prepared in conformance with the design criteria in the technical standard referenced in Part III.B.1 and the *performance criteria* in the technical standard referenced in Parts III.B., 2 or 3, for *construction activities* that require post-construction stormwater management practices pursuant to Part III.C.; or

(ii) Sixty (60) business days from the date the Department receives a complete NOI (electronic or paper version) for *construction activities* with a SWPPP that has not been prepared in conformance with the design criteria in technical standard referenced in Part III.B.1. or, for *construction activities* that require post-construction stormwater management practices pursuant to Part III.C., the *performance criteria* in the technical standard referenced in Parts III.B., 2 or 3, or;

(iii) Ten (10) business days from the date the Department receives a complete paper version of the NOI for *construction activities* with a SWPPP that has been prepared in conformance with the design criteria in the technical standard referenced in Part III.B.1 and the *performance criteria* in the technical standard referenced in Parts III.B., 2 or 3, for *construction activities* that require post-construction stormwater management practices pursuant to Part III.C.

b. For *construction activities* that are subject to the requirements of a *regulated, traditional land use control MS4*:

(i) Five (5) business days from the date the Department receives both a complete electronic version of the NOI (eNOI) and signed “MS4 SWPPP Acceptance” form, or

(ii) Ten (10) business days from the date the Department receives both a complete paper version of the NOI and signed “MS4 SWPPP Acceptance” form.

4. The Department may suspend or deny an *owner’s or operator’s* coverage

(Part II.B.4)

under this permit if the Department determines that the SWPPP does not meet the permit requirements. In accordance with statute, regulation, and the terms and conditions of this permit, the Department may deny coverage under this permit and require submittal of an application for an individual SPDES permit based on a review of the NOI or other information pursuant to Part II.

5. Coverage under this permit authorizes stormwater *discharges* from only those areas of disturbance that are identified in the NOI. If an *owner or operator* wishes to have stormwater *discharges* from future or additional areas of disturbance authorized, they must submit a new NOI that addresses that phase of the development, unless otherwise notified by the Department. The *owner or operator* shall not *commence construction activity* on the future or additional areas until their authorization to *discharge* under this permit goes into effect in accordance with Part II.B. of this permit.

### **C. General Requirements For Owners or Operators With Permit Coverage**

1. The *owner or operator* shall ensure that the provisions of the SWPPP are implemented from the *commencement of construction activity* until all areas of disturbance have achieved *final stabilization* and the Notice of Termination (“NOT”) has been submitted to the Department in accordance with Part V. of this permit. This includes any changes made to the SWPPP pursuant to Part III.A.4. of this permit.
2. The *owner or operator* shall maintain a copy of the General Permit (GP-0-15-002), NOI, *NOI Acknowledgment Letter*, SWPPP, MS4 SWPPP Acceptance form, inspection reports, and all documentation necessary to demonstrate eligibility with this permit at the construction site until all disturbed areas have achieved *final stabilization* and the NOT has been submitted to the Department. The documents must be maintained in a secure location, such as a job trailer, on-site construction office, or mailbox with lock. The secure location must be accessible during normal business hours to an individual performing a compliance inspection.
3. The *owner or operator* of a *construction activity* shall not disturb greater than five (5) acres of soil at any one time without prior written authorization from the Department or, in areas under the jurisdiction of a *regulated, traditional land use control MS4*, the *regulated, traditional land use control MS4* (provided the *regulated, traditional land use control MS4* is not the *owner or operator* of the *construction activity*). At a minimum, the *owner or operator* must comply with the following requirements in order to be authorized to disturb greater than five (5) acres of soil at any one time:
  - a. The *owner or operator* shall

(Part II.C.3.a)

have a *qualified inspector* conduct **at least** two (2) site inspections in accordance with Part IV.C. of this permit every seven (7) calendar days, for as long as greater than five (5) acres of soil remain disturbed. The two (2) inspections shall be separated by a minimum of two (2) full calendar days.

- b. In areas where soil disturbance activity has temporarily or permanently ceased, the application of soil stabilization measures must be initiated by the end of the next business day and completed within seven (7) days from the date the current soil disturbance activity ceased. The soil stabilization measures selected shall be in conformance with the technical standard, New York State Standards and Specifications for Erosion and Sediment Control, dated August 2005.
  - c. The *owner or operator* shall prepare a phasing plan that defines maximum disturbed area per phase and shows required cuts and fills.
  - d. The *owner or operator* shall install any additional site specific practices needed to protect water quality.
  - e. The *owner or operator* shall include the requirements above in their SWPPP.
4. In accordance with statute, regulations, and the terms and conditions of this permit, the Department may suspend or revoke an *owner's or operator's* coverage under this permit at any time if the Department determines that the SWPPP does not meet the permit requirements. Upon a finding of significant non-compliance with the practices described in the SWPPP or violation of this permit, the Department may order an immediate stop to all activity at the site until the non-compliance is remedied. The stop work order shall be in writing, describe the non-compliance in detail, and be sent to the *owner or operator*.
5. For *construction activities* that are subject to the requirements of a *regulated, traditional land use control MS4*, the *owner or operator* shall notify the *regulated, traditional land use control MS4* in writing of any planned amendments or modifications to the post-construction stormwater management practice component of the SWPPP required by Part III.A. 4. and 5. of this permit. Unless otherwise notified by the *regulated, traditional land use control MS4*, the *owner or operator* shall have the SWPPP amendments or modifications reviewed and accepted by the *regulated, traditional land use control MS4* prior to commencing construction of the post-construction stormwater management practice

(Part II.D)

**D. Permit Coverage for Discharges Authorized Under GP-0-10-001**

1. Upon renewal of SPDES General Permit for Stormwater Discharges from *Construction Activity* (Permit No. GP-0-10-001), an *owner or operator* of a *construction activity* with coverage under GP-0-10-001, as of the effective date of GP-0-15-002, shall be authorized to *discharge* in accordance with GP-0-15-002, unless otherwise notified by the Department.

An *owner or operator* may continue to implement the technical/design components of the post-construction stormwater management controls provided that such design was done in conformance with the technical standards in place at the time of initial project authorization. However, they must comply with the other, non-design provisions of GP-0-15-002.

**E. Change of *Owner or Operator***

2. When property ownership changes or when there is a change in operational control over the construction plans and specifications, the original *owner or operator* must notify the new *owner or operator*, in writing, of the requirement to obtain permit coverage by submitting a NOI with the Department. Once the new *owner or operator* obtains permit coverage, the original *owner or operator* shall then submit a completed NOT with the name and permit identification number of the new *owner or operator* to the Department at the address in Part II.A.1. of this permit. If the original *owner or operator* maintains ownership of a portion of the *construction activity* and will disturb soil, they must maintain their coverage under the permit.

Permit coverage for the new *owner or operator* will be effective as of the date the Department receives a complete NOI, provided the original *owner or operator* was not subject to a sixty (60) business day authorization period that has not expired as of the date the Department receives the NOI from the new *owner or operator*.

(Part III)

III. **Part III. STORMWATER POLLUTION PREVENTION PLAN (SWPPP)**

**A. General SWPPP Requirements**

1. A SWPPP shall be prepared and implemented by the *owner or operator* of each *construction activity* covered by this permit. The SWPPP must document the selection, design, installation, implementation and maintenance of the control measures and practices that will be used to meet the effluent limitations in Part I.B. of this permit and where applicable, the post-construction stormwater management practice requirements in Part I.C. of this permit. The SWPPP shall be prepared prior to the submittal of the NOI. The NOI shall be submitted to the Department prior to the *commencement of construction activity*. A copy of the completed, final NOI shall be included in the SWPPP.
2. The SWPPP shall describe the erosion and sediment control practices and where required, post-construction stormwater management practices that will be used and/or constructed to reduce the *pollutants* in stormwater *discharges* and to assure compliance with the terms and conditions of this permit. In addition, the SWPPP shall identify potential sources of pollution which may reasonably be expected to affect the quality of stormwater *discharges*.
3. All SWPPPs that require the post-construction stormwater management practice component shall be prepared by a *qualified professional* that is knowledgeable in the principles and practices of stormwater management and treatment.
4. The *owner or operator* must keep the SWPPP current so that it at all times accurately documents the erosion and sediment controls practices that are being used or will be used during construction, and all post-construction stormwater management practices that will be constructed on the site. At a minimum, the *owner or operator* shall amend the SWPPP:
  - a. whenever the current provisions prove to be ineffective in minimizing *pollutants* in stormwater *discharges* from the site;
  - b. whenever there is a change in design, construction, or operation at the construction site that has or could have an effect on the *discharge* of *pollutants*; and
  - c. to address issues or deficiencies identified during an inspection by the *qualified inspector*, the Department or other regulatory authority.
5. The Department may notify the *owner or operator* at any time that the



(Part III.A.5)

SWPPP does not meet one or more of the minimum requirements of this permit. The notification shall be in writing and identify the provisions of the SWPPP that require modification. Within fourteen (14) calendar days of such notification, or as otherwise indicated by the Department, the *owner or operator* shall make the required changes to the SWPPP and submit written notification to the Department that the changes have been made. If the *owner or operator* does not respond to the Department's comments in the specified time frame, the Department may suspend the *owner's or operator's* coverage under this permit or require the *owner or operator* to obtain coverage under an individual SPDES permit in accordance with Part II.C.4. of this permit.

6. Prior to the *commencement of construction activity*, the *owner or operator* must identify the contractor(s) and subcontractor(s) that will be responsible for installing, constructing, repairing, replacing, inspecting and maintaining the erosion and sediment control practices included in the SWPPP; and the contractor(s) and subcontractor(s) that will be responsible for constructing the post-construction stormwater management practices included in the SWPPP. The *owner or operator* shall have each of the contractors and subcontractors identify at least one person from their company that will be responsible for implementation of the SWPPP. This person shall be known as the *trained contractor*. The *owner or operator* shall ensure that at least one *trained contractor* is on site on a daily basis when soil disturbance activities are being performed.

The *owner or operator* shall have each of the contractors and subcontractors identified above sign a copy of the following certification statement below before they commence any *construction activity*:

"I hereby certify under penalty of law that I understand and agree to comply with the terms and conditions of the SWPPP and agree to implement any corrective actions identified by the *qualified inspector* during a site inspection. I also understand that the *owner or operator* must comply with the terms and conditions of the most current version of the New York State Pollutant Discharge Elimination System ("SPDES") general permit for stormwater *discharges* from *construction activities* and that it is unlawful for any person to cause or contribute to a violation of *water quality standards*. Furthermore, I am aware that there are significant penalties for submitting false information, that I do not believe to be true, including the possibility of fine and imprisonment for knowing violations"

In addition to providing the certification statement above, the certification page must also identify the specific elements of the SWPPP that each contractor and subcontractor will be responsible for and include the name and title of the person providing the signature; the name and title of the

(Part III.A.6)

*trained contractor* responsible for SWPPP implementation; the name, address and telephone number of the contracting firm; the address (or other identifying description) of the site; and the date the certification statement is signed. The *owner or operator* shall attach the certification statement(s) to the copy of the SWPPP that is maintained at the construction site. If new or additional contractors are hired to implement measures identified in the SWPPP after construction has commenced, they must also sign the certification statement and provide the information listed above.

7. For projects where the Department requests a copy of the SWPPP or inspection reports, the *owner or operator* shall submit the documents in both electronic (PDF only) and paper format within five (5) business days, unless otherwise notified by the Department.

**B. Required SWPPP Contents**

1. Erosion and sediment control component - All SWPPPs prepared pursuant to this permit shall include erosion and sediment control practices designed in conformance with the technical standard, New York State Standards and Specifications for Erosion and Sediment Control, dated August 2005. Where erosion and sediment control practices are not designed in conformance with the design criteria included in the technical standard, the *owner or operator* must demonstrate *equivalence* to the technical standard. At a minimum, the erosion and sediment control component of the SWPPP shall include the following:
  - a. Background information about the scope of the project, including the location, type and size of project;
  - b. A site map/construction drawing(s) for the project, including a general location map. At a minimum, the site map shall show the total site area; all improvements; areas of disturbance; areas that will not be disturbed; existing vegetation; on-site and adjacent off-site surface water(s); floodplain/floodway boundaries; wetlands and drainage patterns that could be affected by the *construction activity*; existing and final contours ; locations of different soil types with boundaries; material, waste, borrow or equipment storage areas located on adjacent properties; and location(s) of the stormwater *discharge(s)*;
  - c. A description of the soil(s) present at the site, including an identification of the Hydrologic Soil Group (HSG);
  - d. A construction phasing plan and sequence of operations describing the intended order of *construction activities*, including clearing and grubbing, excavation and grading, utility and infrastructure installation and any other

(Part III.B.1.d)

activity at the site that results in soil disturbance;

- e. A description of the minimum erosion and sediment control practices to be installed or implemented for each *construction activity* that will result in soil disturbance. Include a schedule that identifies the timing of initial placement or implementation of each erosion and sediment control practice and the minimum time frames that each practice should remain in place or be implemented;
- f. A temporary and permanent soil stabilization plan that meets the requirements of this general permit and the technical standard, New York State Standards and Specifications for Erosion and Sediment Control, dated August 2005, for each stage of the project, including initial land clearing and grubbing to project completion and achievement of *final stabilization*;
- g. A site map/construction drawing(s) showing the specific location(s), size(s), and length(s) of each erosion and sediment control practice;
- h. The dimensions, material specifications, installation details, and operation and maintenance requirements for all erosion and sediment control practices. Include the location and sizing of any temporary sediment basins and structural practices that will be used to divert flows from exposed soils;
- i. A maintenance inspection schedule for the contractor(s) identified in Part III.A.6. of this permit, to ensure continuous and effective operation of the erosion and sediment control practices. The maintenance inspection schedule shall be in accordance with the requirements in the technical standard, New York State Standards and Specifications for Erosion and Sediment Control, dated August 2005;
- j. A description of the pollution prevention measures that will be used to control litter, construction chemicals and construction debris from becoming a *pollutant* source in the stormwater *discharges*;
- k. A description and location of any stormwater *discharges* associated with industrial activity other than construction at the site, including, but not limited to, stormwater *discharges* from asphalt plants and concrete plants located on the construction site; and
- l. Identification of any elements of the design that are not in conformance with the design criteria in the technical standard, New York State Standards and Specifications for Erosion and Sediment Control, dated August 2005. Include the reason for the deviation or alternative design

(Part III.B.1.I)

and provide information which demonstrates that the deviation or alternative design is *equivalent* to the technical standard.

2. Post-construction stormwater management practice component – The *owner or operator* of any construction project identified in Table 2 of Appendix B as needing post-construction stormwater management practices shall prepare a SWPPP that includes practices designed in conformance with the applicable *sizing criteria* in Part I.C.2.a., c. or d. of this permit and the *performance criteria* in the technical standard, New York State Stormwater Management Design Manual dated January 2015

Where post-construction stormwater management practices are not designed in conformance with the *performance criteria* in the technical standard, the *owner or operator* must include in the SWPPP the reason(s) for the deviation or alternative design and provide information which demonstrates that the deviation or alternative design is *equivalent* to the technical standard.

The post-construction stormwater management practice component of the SWPPP shall include the following:

- a. Identification of all post-construction stormwater management practices to be constructed as part of the project. Include the dimensions, material specifications and installation details for each post-construction stormwater management practice;
- b. A site map/construction drawing(s) showing the specific location and size of each post-construction stormwater management practice;
- c. A Stormwater Modeling and Analysis Report that includes:
  - (i) Map(s) showing pre-development conditions, including watershed/subcatchments boundaries, flow paths/routing, and design points;
  - (ii) Map(s) showing post-development conditions, including watershed/subcatchments boundaries, flow paths/routing, design points and post-construction stormwater management practices;
  - (iii) Results of stormwater modeling (i.e. hydrology and hydraulic analysis) for the required storm events. Include supporting calculations (model runs), methodology, and a summary table that compares pre and post-development runoff rates and volumes for the different storm events;
  - (iv) Summary table, with supporting calculations, which demonstrates

(Part III.B.2.c.iv)

that each post-construction stormwater management practice has been designed in conformance with the *sizing criteria* included in the Design Manual;

- (v) Identification of any *sizing criteria* that is not required based on the requirements included in Part I.C. of this permit; and
  - (vi) Identification of any elements of the design that are not in conformance with the *performance criteria* in the Design Manual. Include the reason(s) for the deviation or alternative design and provide information which demonstrates that the deviation or alternative design is *equivalent* to the Design Manual;
- d. Soil testing results and locations (test pits, borings);
  - e. Infiltration test results, when required; and
  - f. An operations and maintenance plan that includes inspection and maintenance schedules and actions to ensure continuous and effective operation of each post-construction stormwater management practice. The plan shall identify the entity that will be responsible for the long term operation and maintenance of each practice.
3. Enhanced Phosphorus Removal Standards - All construction projects identified in Table 2 of Appendix B that are located in the watersheds identified in Appendix C shall prepare a SWPPP that includes post-construction stormwater management practices designed in conformance with the applicable *sizing criteria* in Part I.C.2. b., c. or d. of this permit and the *performance criteria*, Enhanced Phosphorus Removal Standards included in the Design Manual. At a minimum, the post-construction stormwater management practice component of the SWPPP shall include items 2.a - 2.f. above.

### **C. Required SWPPP Components by Project Type**

Unless otherwise notified by the Department, *owners or operators of construction activities* identified in Table 1 of Appendix B are required to prepare a SWPPP that only includes erosion and sediment control practices designed in conformance with Part III.B.1 of this permit. *Owners or operators of the construction activities* identified in Table 2 of Appendix B shall prepare a SWPPP that also includes post-construction stormwater management practices designed in conformance with Part III.B.2 or 3 of this permit.

(Part IV)

#### IV. Part IV. INSPECTION AND MAINTENANCE REQUIREMENTS

##### A. General Construction Site Inspection and Maintenance Requirements

1. The *owner or operator* must ensure that all erosion and sediment control practices (including pollution prevention measures) and all post-construction stormwater management practices identified in the SWPPP are inspected and maintained in accordance with Part IV.B. and C. of this permit.
2. The terms of this permit shall not be construed to prohibit the State of New York from exercising any authority pursuant to the ECL, common law or federal law, or prohibit New York State from taking any measures, whether civil or criminal, to prevent violations of the laws of the State of New York, or protect the public health and safety and/or the environment.

##### B. Contractor Maintenance Inspection Requirements

1. The *owner or operator* of each *construction activity* identified in Tables 1 and 2 of Appendix B shall have a *trained contractor* inspect the erosion and sediment control practices and pollution prevention measures being implemented within the active work area daily to ensure that they are being maintained in effective operating condition at all times. If deficiencies are identified, the contractor shall begin implementing corrective actions within one business day and shall complete the corrective actions in a reasonable time frame.
2. For construction sites where soil disturbance activities have been temporarily suspended (e.g. winter shutdown) and *temporary stabilization* measures have been applied to all disturbed areas, the *trained contractor* can stop conducting the maintenance inspections. The *trained contractor* shall begin conducting the maintenance inspections in accordance with Part IV.B.1. of this permit as soon as soil disturbance activities resume.
3. For construction sites where soil disturbance activities have been shut down with partial project completion, the *trained contractor* can stop conducting the maintenance inspections if all areas disturbed as of the project shutdown date have achieved *final stabilization* and all post-construction stormwater management practices required for the completed portion of the project have been constructed in conformance with the SWPPP and are operational.

##### C. Qualified Inspector Inspection Requirements

(Part IV.C)

The *owner or operator* shall have a *qualified inspector* conduct site inspections in conformance with the following requirements:

[Note: The *trained contractor* identified in Part III.A.6. and IV.B. of this permit **cannot** conduct the *qualified inspector* site inspections unless they meet the *qualified inspector* qualifications included in Appendix A. In order to perform these inspections, the *trained contractor* would have to be a:

- licensed Professional Engineer,
- Certified Professional in Erosion and Sediment Control (CPESC),
- Registered Landscape Architect, or
- someone working under the direct supervision of, and at the same company as, the licensed Professional Engineer or Registered Landscape Architect, provided they have received four (4) hours of Department endorsed training in proper erosion and sediment control principles from a Soil and Water Conservation District, or other Department endorsed entity].

1. A *qualified inspector* shall conduct site inspections for all *construction activities* identified in Tables 1 and 2 of Appendix B, with the exception of:
  - a. the construction of a single family residential subdivision with 25% or less *impervious cover* at total site build-out that involves a soil disturbance of one (1) or more acres of land but less than five (5) acres and is not located in one of the watersheds listed in Appendix C and not directly discharging to one of the 303(d) segments listed in Appendix E;
  - b. the construction of a single family home that involves a soil disturbance of one (1) or more acres of land but less than five (5) acres and is not located in one of the watersheds listed in Appendix C and not directly discharging to one of the 303(d) segments listed in Appendix E;
  - c. construction on agricultural property that involves a soil disturbance of one (1) or more acres of land but less than five (5) acres; and
  - d. *construction activities* located in the watersheds identified in Appendix D that involve soil disturbances between five thousand (5,000) square feet and one (1) acre of land.
2. Unless otherwise notified by the Department, the *qualified inspector* shall conduct site inspections in accordance with the following timetable:
  - a. For construction sites where soil disturbance activities are on-going, the *qualified inspector* shall conduct a site inspection at least once every seven (7) calendar days.
  - b. For construction sites where soil disturbance activities are on-going and

(Part IV.C.2.b)

the *owner or operator* has received authorization in accordance with Part II.C.3 to disturb greater than five (5) acres of soil at any one time, the *qualified inspector* shall conduct at least two (2) site inspections every seven (7) calendar days. The two (2) inspections shall be separated by a minimum of two (2) full calendar days.

- c. For construction sites where soil disturbance activities have been temporarily suspended (e.g. winter shutdown) and *temporary stabilization* measures have been applied to all disturbed areas, the *qualified inspector* shall conduct a site inspection at least once every thirty (30) calendar days. The *owner or operator* shall notify the DOW Water (SPDES) Program contact at the Regional Office (see contact information in Appendix F) or, in areas under the jurisdiction of a *regulated, traditional land use control MS4*, the *regulated, traditional land use control MS4* (provided the *regulated, traditional land use control MS4* is not the *owner or operator* of the *construction activity*) in writing prior to reducing the frequency of inspections.
- d. For construction sites where soil disturbance activities have been shut down with partial project completion, the *qualified inspector* can stop conducting inspections if all areas disturbed as of the project shutdown date have achieved *final stabilization* and all post-construction stormwater management practices required for the completed portion of the project have been constructed in conformance with the SWPPP and are operational. The *owner or operator* shall notify the DOW Water (SPDES) Program contact at the Regional Office (see contact information in Appendix F) or, in areas under the jurisdiction of a *regulated, traditional land use control MS4*, the *regulated, traditional land use control MS4* (provided the *regulated, traditional land use control MS4* is not the *owner or operator* of the *construction activity*) in writing prior to the shutdown. If soil disturbance activities are not resumed within 2 years from the date of shutdown, the *owner or operator* shall have the *qualified inspector* perform a final inspection and certify that all disturbed areas have achieved *final stabilization*, and all temporary, structural erosion and sediment control measures have been removed; and that all post-construction stormwater management practices have been constructed in conformance with the SWPPP by signing the “*Final Stabilization*” and “*Post-Construction Stormwater Management Practice*” certification statements on the NOT. The *owner or operator* shall then submit the completed NOT form to the address in Part II.A.1 of this permit.
- e. For construction sites that directly *discharge* to one of the 303(d) segments listed in Appendix E or is located in one of the watersheds listed in Appendix C, the *qualified inspector* shall conduct at least two (2) site inspections every seven (7) calendar days. The two (2) inspections shall



(Part IV.C.2.e)

be separated by a minimum of two (2) full calendar days.

3. At a minimum, the *qualified inspector* shall inspect all erosion and sediment control practices and pollution prevention measures to ensure integrity and effectiveness, all post-construction stormwater management practices under construction to ensure that they are constructed in conformance with the SWPPP, all areas of disturbance that have not achieved *final stabilization*, all points of *discharge* to natural surface waterbodies located within, or immediately adjacent to, the property boundaries of the construction site, and all points of *discharge* from the construction site.
4. The *qualified inspector* shall prepare an inspection report subsequent to each and every inspection. At a minimum, the inspection report shall include and/or address the following:
  - a. Date and time of inspection;
  - b. Name and title of person(s) performing inspection;
  - c. A description of the weather and soil conditions (e.g. dry, wet, saturated) at the time of the inspection;
  - d. A description of the condition of the runoff at all points of *discharge* from the construction site. This shall include identification of any *discharges* of sediment from the construction site. Include *discharges* from conveyance systems (i.e. pipes, culverts, ditches, etc.) and overland flow;
  - e. A description of the condition of all natural surface waterbodies located within, or immediately adjacent to, the property boundaries of the construction site which receive runoff from disturbed areas. This shall include identification of any *discharges* of sediment to the surface waterbody;
  - f. Identification of all erosion and sediment control practices and pollution prevention measures that need repair or maintenance;
  - g. Identification of all erosion and sediment control practices and pollution prevention measures that were not installed properly or are not functioning as designed and need to be reinstalled or replaced;
  - h. Description and sketch of areas with active soil disturbance activity, areas that have been disturbed but are inactive at the time of the inspection, and areas that have been stabilized (temporary and/or final) since the last inspection;

(Part IV.C.4.i)

- i. Current phase of construction of all post-construction stormwater management practices and identification of all construction that is not in conformance with the SWPPP and technical standards;
  - j. Corrective action(s) that must be taken to install, repair, replace or maintain erosion and sediment control practices and pollution prevention measures; and to correct deficiencies identified with the construction of the post-construction stormwater management practice(s);
  - k. Identification and status of all corrective actions that were required by previous inspection; and
  - l. Digital photographs, with date stamp, that clearly show the condition of all practices that have been identified as needing corrective actions. The *qualified inspector* shall attach paper color copies of the digital photographs to the inspection report being maintained onsite within seven (7) calendar days of the date of the inspection. The *qualified inspector* shall also take digital photographs, with date stamp, that clearly show the condition of the practice(s) after the corrective action has been completed. The *qualified inspector* shall attach paper color copies of the digital photographs to the inspection report that documents the completion of the corrective action work within seven (7) calendar days of that inspection.
5. Within one business day of the completion of an inspection, the *qualified inspector* shall notify the *owner or operator* and appropriate contractor or subcontractor identified in Part III.A.6. of this permit of any corrective actions that need to be taken. The contractor or subcontractor shall begin implementing the corrective actions within one business day of this notification and shall complete the corrective actions in a reasonable time frame.
  6. All inspection reports shall be signed by the *qualified inspector*. Pursuant to Part II.C.2. of this permit, the inspection reports shall be maintained on site with the SWPPP.

V. **Part V. TERMINATION OF PERMIT COVERAGE**

**A. Termination of Permit Coverage**

1. An *owner or operator* that is eligible to terminate coverage under this permit must submit a completed NOT form to the address in Part II.A.1 of this permit. The NOT form shall be one which is associated with this permit, signed in accordance with Part VII.H of this permit.

(Part V.A.2)

2. An *owner or operator* may terminate coverage when one or more the following conditions have been met:
  - a. Total project completion - All *construction activity* identified in the SWPPP has been completed; and all areas of disturbance have achieved *final stabilization*; and all temporary, structural erosion and sediment control measures have been removed; and all post-construction stormwater management practices have been constructed in conformance with the SWPPP and are operational;
  - b. Planned shutdown with partial project completion - All soil disturbance activities have ceased; and all areas disturbed as of the project shutdown date have achieved *final stabilization*; and all temporary, structural erosion and sediment control measures have been removed; and all post-construction stormwater management practices required for the completed portion of the project have been constructed in conformance with the SWPPP and are operational;
  - c. A new *owner or operator* has obtained coverage under this permit in accordance with Part II.E. of this permit.
  - d. The *owner or operator* obtains coverage under an alternative SPDES general permit or an individual SPDES permit.
3. For *construction activities* meeting subdivision 2a. or 2b. of this Part, the *owner or operator* shall have the *qualified inspector* perform a final site inspection prior to submitting the NOT. The *qualified inspector* shall, by signing the “*Final Stabilization*” and “*Post-Construction Stormwater Management Practice certification statements*” on the NOT, certify that all the requirements in Part V.A.2.a. or b. of this permit have been achieved.
4. For *construction activities* that are subject to the requirements of a *regulated, traditional land use control MS4* and meet subdivision 2a. or 2b. of this Part, the *owner or operator* shall have the *regulated, traditional land use control MS4* sign the “*MS4 Acceptance*” statement on the NOT in accordance with the requirements in Part VII.H. of this permit. The *regulated, traditional land use control MS4* official, by signing this statement, has determined that it is acceptable for the *owner or operator* to submit the NOT in accordance with the requirements of this Part. The *regulated, traditional land use control MS4* can make this determination by performing a final site inspection themselves or by accepting the *qualified inspector’s* final site inspection certification(s) required in Part V.A.3. of this permit.

(Part V.A.5)

5. For *construction activities* that require post-construction stormwater management practices and meet subdivision 2a. of this Part, the *owner or operator* must, prior to submitting the NOT, ensure one of the following:
  - a. the post-construction stormwater management practice(s) and any right-of-way(s) needed to maintain such practice(s) have been deeded to the municipality in which the practice(s) is located,
  - b. an executed maintenance agreement is in place with the municipality that will maintain the post-construction stormwater management practice(s),
  - c. for post-construction stormwater management practices that are privately owned, the *owner or operator* has a mechanism in place that requires operation and maintenance of the practice(s) in accordance with the operation and maintenance plan, such as a deed covenant in the *owner or operator's* deed of record,
  - d. for post-construction stormwater management practices that are owned by a public or private institution (e.g. school, university, hospital), government agency or authority, or public utility; the *owner or operator* has policy and procedures in place that ensures operation and maintenance of the practices in accordance with the operation and maintenance plan.

## VI. Part VI. REPORTING AND RETENTION OF RECORDS

### A. Record Retention

The *owner or operator* shall retain a copy of the NOI, NOI Acknowledgment Letter, SWPPP, MS4 SWPPP Acceptance form and any inspection reports that were prepared in conjunction with this permit for a period of at least five (5) years from the date that the Department receives a complete NOT submitted in accordance with Part V. of this general permit.

### B. Addresses

With the exception of the NOI, NOT, and MS4 SWPPP Acceptance form (which must be submitted to the address referenced in Part II.A.1 of this permit), all written correspondence requested by the Department, including individual permit applications, shall be sent to the address of the appropriate DOW Water (SPDES) Program contact at the Regional Office listed in Appendix F.

(Part VII)

**VII. Part VII. STANDARD PERMIT CONDITIONS**

**A. Duty to Comply**

The *owner or operator* must comply with all conditions of this permit. All contractors and subcontractors associated with the project must comply with the terms of the SWPPP. Any non-compliance with this permit constitutes a violation of the Clean Water Act (CWA) and the ECL and is grounds for an enforcement action against the *owner or operator* and/or the contractor/subcontractor; permit revocation, suspension or modification; or denial of a permit renewal application. Upon a finding of significant non-compliance with this permit or the applicable SWPPP, the Department may order an immediate stop to all *construction activity* at the site until the non-compliance is remedied. The stop work order shall be in writing, shall describe the non-compliance in detail, and shall be sent to the *owner or operator*.

If any human remains or archaeological remains are encountered during excavation, the *owner or operator* must immediately cease, or cause to cease, all *construction activity* in the area of the remains and notify the appropriate Regional Water Engineer (RWE). *Construction activity* shall not resume until written permission to do so has been received from the RWE.

**B. Continuation of the Expired General Permit**

This permit expires five (5) years from the effective date. If a new general permit is not issued prior to the expiration of this general permit, an *owner or operator* with coverage under this permit may continue to operate and *discharge* in accordance with the terms and conditions of this general permit, if it is extended pursuant to the State Administrative Procedure Act and 6 NYCRR Part 621, until a new general permit is issued.

**C. Enforcement**

Failure of the *owner or operator*, its contractors, subcontractors, agents and/or assigns to strictly adhere to any of the permit requirements contained herein shall constitute a violation of this permit. There are substantial criminal, civil, and administrative penalties associated with violating the provisions of this permit. Fines of up to \$37,500 per day for each violation and imprisonment for up to fifteen (15) years may be assessed depending upon the nature and degree of the offense.

**D. Need to Halt or Reduce Activity Not a Defense**

It shall not be a defense for an *owner or operator* in an enforcement action that it would have been necessary to halt or reduce the *construction activity* in order to maintain compliance with the conditions of this permit.

(Part VII.E)

### **E. Duty to Mitigate**

The *owner or operator* and its contractors and subcontractors shall take all reasonable steps to *minimize* or prevent any *discharge* in violation of this permit which has a reasonable likelihood of adversely affecting human health or the environment.

### **F. Duty to Provide Information**

The *owner or operator* shall furnish to the Department, within a reasonable specified time period of a written request, all documentation necessary to demonstrate eligibility and any information to determine compliance with this permit or to determine whether cause exists for modifying or revoking this permit, or suspending or denying coverage under this permit, in accordance with the terms and conditions of this permit. The NOI, SWPPP and inspection reports required by this permit are public documents that the *owner or operator* must make available for review and copying by any person within five (5) business days of the *owner or operator* receiving a written request by any such person to review these documents. Copying of documents will be done at the requester's expense.

### **G. Other Information**

When the *owner or operator* becomes aware that they failed to submit any relevant facts, or submitted incorrect information in the NOI or in any of the documents required by this permit, or have made substantive revisions to the SWPPP (e.g. the scope of the project changes significantly, the type of post-construction stormwater management practice(s) changes, there is a reduction in the sizing of the post-construction stormwater management practice, or there is an increase in the disturbance area or *impervious area*), which were not reflected in the original NOI submitted to the Department, they shall promptly submit such facts or information to the Department using the contact information in Part II.A. of this permit. Failure of the *owner or operator* to correct or supplement any relevant facts within five (5) business days of becoming aware of the deficiency shall constitute a violation of this permit.

### **H. Signatory Requirements**

1. All NOIs and NOTs shall be signed as follows:
  - a. For a corporation these forms shall be signed by a responsible corporate officer. For the purpose of this section, a responsible corporate officer means:
    - (i) a president, secretary, treasurer, or vice-president of the

(Part VII.H.1.a.i)

corporation in charge of a principal business function, or any other person who performs similar policy or decision-making functions for the corporation; or

- (ii) the manager of one or more manufacturing, production or operating facilities, provided the manager is authorized to make management decisions which govern the operation of the regulated facility including having the explicit or implicit duty of making major capital investment recommendations, and initiating and directing other comprehensive measures to assure long term environmental compliance with environmental laws and regulations; the manager can ensure that the necessary systems are established or actions taken to gather complete and accurate information for permit application requirements; and where authority to sign documents has been assigned or delegated to the manager in accordance with corporate procedures;

b. For a partnership or sole proprietorship these forms shall be signed by a general partner or the proprietor, respectively; or

c. For a municipality, State, Federal, or other public agency these forms shall be signed by either a principal executive officer or ranking elected official. For purposes of this section, a principal executive officer of a Federal agency includes:

- (i) the chief executive officer of the agency, or

- (ii) a senior executive officer having responsibility for the overall operations of a principal geographic unit of the agency (e.g., Regional Administrators of EPA).

2. The SWPPP and other information requested by the Department shall be signed by a person described in Part VII.H.1. of this permit or by a duly authorized representative of that person. A person is a duly authorized representative only if:

a. The authorization is made in writing by a person described in Part VII.H.1. of this permit;

b. The authorization specifies either an individual or a position having responsibility for the overall operation of the regulated facility or activity, such as the position of plant manager, operator of a well or a well field, superintendent, position of *equivalent* responsibility, or an individual or position having overall responsibility for environmental matters for the company. (A duly authorized representative may thus be either a named

(Part VII.H.2.b)

individual or any individual occupying a named position) and,

- c. The written authorization shall include the name, title and signature of the authorized representative and be attached to the SWPPP.
3. All inspection reports shall be signed by the *qualified inspector* that performs the inspection.
4. The MS4 SWPPP Acceptance form shall be signed by the principal executive officer or ranking elected official from the *regulated, traditional land use control MS4*, or by a duly authorized representative of that person.

It shall constitute a permit violation if an incorrect and/or improper signatory authorizes any required forms, SWPPP and/or inspection reports.

#### **I. Property Rights**

The issuance of this permit does not convey any property rights of any sort, nor any exclusive privileges, nor does it authorize any injury to private property nor any invasion of personal rights, nor any infringement of Federal, State or local laws or regulations. *Owners or operators* must obtain any applicable conveyances, easements, licenses and/or access to real property prior to *commencing construction activity*.

#### **J. Severability**

The provisions of this permit are severable, and if any provision of this permit, or the application of any provision of this permit to any circumstance, is held invalid, the application of such provision to other circumstances, and the remainder of this permit shall not be affected thereby.

#### **K. Requirement to Obtain Coverage Under an Alternative Permit**

1. The Department may require any *owner or operator* authorized by this permit to apply for and/or obtain either an individual SPDES permit or another SPDES general permit. When the Department requires any *discharger* authorized by a general permit to apply for an individual SPDES permit, it shall notify the *discharger* in writing that a permit application is required. This notice shall include a brief statement of the reasons for this decision, an application form, a statement setting a time frame for the *owner or operator* to file the application for an individual SPDES permit, and a deadline, not sooner than 180 days from *owner or operator* receipt of the notification letter, whereby the authorization to



(Part VII.K.1)

*discharge* under this general permit shall be terminated. Applications must be submitted to the appropriate Permit Administrator at the Regional Office. The Department may grant additional time upon demonstration, to the satisfaction of the Department, that additional time to apply for an alternative authorization is necessary or where the Department has not provided a permit determination in accordance with Part 621 of this Title.

2. When an individual SPDES permit is issued to a discharger authorized to *discharge* under a general SPDES permit for the same *discharge(s)*, the general permit authorization for outfalls authorized under the individual SPDES permit is automatically terminated on the effective date of the individual permit unless termination is earlier in accordance with 6 NYCRR Part 750.

#### **L. Proper Operation and Maintenance**

The *owner or operator* shall at all times properly operate and maintain all facilities and systems of treatment and control (and related appurtenances) which are installed or used by the *owner or operator* to achieve compliance with the conditions of this permit and with the requirements of the SWPPP.

#### **M. Inspection and Entry**

The *owner or operator* shall allow an authorized representative of the Department, EPA, applicable county health department, or, in the case of a construction site which *discharges* through an *MS4*, an authorized representative of the *MS4* receiving the discharge, upon the presentation of credentials and other documents as may be required by law, to:

1. Enter upon the *owner's or operator's* premises where a regulated facility or activity is located or conducted or where records must be kept under the conditions of this permit;
2. Have access to and copy at reasonable times, any records that must be kept under the conditions of this permit; and
3. Inspect at reasonable times any facilities or equipment (including monitoring and control equipment), practices or operations regulated or required by this permit.
4. Sample or monitor at reasonable times, for purposes of assuring permit compliance or as otherwise authorized by the Act or ECL, any substances or parameters at any location.

(Part VII.N)

**N. Permit Actions**

This permit may, at any time, be modified, suspended, revoked, or renewed by the Department in accordance with 6 NYCRR Part 621. The filing of a request by the *owner or operator* for a permit modification, revocation and reissuance, termination, a notification of planned changes or anticipated noncompliance does not limit, diminish and/or stay compliance with any terms of this permit.

**O. Definitions**

Definitions of key terms are included in Appendix A of this permit.

**P. Re-Opener Clause**

1. If there is evidence indicating potential or realized impacts on water quality due to any stormwater discharge associated with *construction activity* covered by this permit, the *owner or operator* of such discharge may be required to obtain an individual permit or alternative general permit in accordance with Part VII.K. of this permit or the permit may be modified to include different limitations and/or requirements.
2. Any Department initiated permit modification, suspension or revocation will be conducted in accordance with 6 NYCRR Part 621, 6 NYCRR 750-1.18, and 6 NYCRR 750-1.20.

**Q. Penalties for Falsification of Forms and Reports**

In accordance with 6NYCRR Part 750-2.4 and 750-2.5, any person who knowingly makes any false material statement, representation, or certification in any application, record, report or other document filed or required to be maintained under this permit, including reports of compliance or noncompliance shall, upon conviction, be punished in accordance with ECL §71-1933 and or Articles 175 and 210 of the New York State Penal Law.

**R. Other Permits**

Nothing in this permit relieves the *owner or operator* from a requirement to obtain any other permits required by law.

## VIII. APPENDIX A

### Definitions

**Alter Hydrology from Pre to Post-Development Conditions** - means the post-development peak flow rate(s) has increased by more than 5% of the pre-developed condition for the design storm of interest (e.g. 10 yr and 100 yr).

**Combined Sewer** - means a sewer that is designed to collect and convey both “sewage” and “stormwater”.

**Commence (Commencement of) Construction Activities** - means the initial disturbance of soils associated with clearing, grading or excavation activities; or other construction related activities that disturb or expose soils such as demolition, stockpiling of fill material, and the initial installation of erosion and sediment control practices required in the SWPPP. See definition for “*Construction Activity(ies)*” also.

**Construction Activity(ies)** - means any clearing, grading, excavation, filling, demolition or stockpiling activities that result in soil disturbance. Clearing activities can include, but are not limited to, logging equipment operation, the cutting and skidding of trees, stump removal and/or brush root removal. Construction activity does not include routine maintenance that is performed to maintain the original line and grade, hydraulic capacity, or original purpose of a facility.

**Direct Discharge (to a specific surface waterbody)** - means that runoff flows from a construction site by overland flow and the first point of discharge is the specific surface waterbody, or runoff flows from a construction site to a separate storm sewer system and the first point of discharge from the separate storm sewer system is the specific surface waterbody.

**Discharge(s)** - means any addition of any pollutant to waters of the State through an outlet or point source.

**Environmental Conservation Law (ECL)** - means chapter 43-B of the Consolidated Laws of the State of New York, entitled the Environmental Conservation Law.

**Equivalent (Equivalence)** – means that the practice or measure meets all the performance, longevity, maintenance, and safety objectives of the technical standard and will provide an equal or greater degree of water quality protection.

**Final Stabilization** - means that all soil disturbance activities have ceased and a uniform, perennial vegetative cover with a density of eighty (80) percent over the entire pervious surface has been established; or other equivalent stabilization measures, such as permanent landscape mulches, rock rip-rap or washed/crushed stone have been applied

on all disturbed areas that are not covered by permanent structures, concrete or pavement.

**General SPDES permit** - means a SPDES permit issued pursuant to 6 NYCRR Part 750-1.21 and Section 70-0117 of the ECL authorizing a category of discharges.

**Groundwater(s)** - means waters in the saturated zone. The saturated zone is a subsurface zone in which all the interstices are filled with water under pressure greater than that of the atmosphere. Although the zone may contain gas-filled interstices or interstices filled with fluids other than water, it is still considered saturated.

**Historic Property** – means any building, structure, site, object or district that is listed on the State or National Registers of Historic Places or is determined to be eligible for listing on the State or National Registers of Historic Places.

**Impervious Area (Cover)** - means all impermeable surfaces that cannot effectively infiltrate rainfall. This includes paved, concrete and gravel surfaces (i.e. parking lots, driveways, roads, runways and sidewalks); building rooftops and miscellaneous impermeable structures such as patios, pools, and sheds.

**Infeasible** – means not technologically possible, or not economically practicable and achievable in light of best industry practices.

**Larger Common Plan of Development or Sale** - means a contiguous area where multiple separate and distinct *construction activities* are occurring, or will occur, under one plan. The term “plan” in “larger common plan of development or sale” is broadly defined as any announcement or piece of documentation (including a sign, public notice or hearing, marketing plan, advertisement, drawing, permit application, State Environmental Quality Review Act (SEQRA) environmental assessment form or other documents, zoning request, computer design, etc.) or physical demarcation (including boundary signs, lot stakes, surveyor markings, etc.) indicating that *construction activities* may occur on a specific plot.

For discrete construction projects that are located within a larger common plan of development or sale that are at least 1/4 mile apart, each project can be treated as a separate plan of development or sale provided any interconnecting road, pipeline or utility project that is part of the same “common plan” is not concurrently being disturbed.

**Minimize** – means reduce and/or eliminate to the extent achievable using control measures (including best management practices) that are technologically available and economically practicable and achievable in light of best industry practices.

**Municipal Separate Storm Sewer (MS4)** - a conveyance or system of conveyances (including roads with drainage systems, municipal streets, catch basins, curbs, gutters,

ditches, man-made channels, or storm drains):

- (i) Owned or operated by a State, city, town, borough, county, parish, district, association, or other public body (created by or pursuant to State law) having jurisdiction over disposal of sewage, industrial wastes, stormwater, or other wastes, including special districts under State law such as a sewer district, flood control district or drainage district, or similar entity, or an Indian tribe or an authorized Indian tribal organization, or a designated and approved management agency under section 208 of the CWA that discharges to surface waters of the State;
- (ii) Designed or used for collecting or conveying stormwater;
- (iii) Which is not a *combined sewer*; and
- (iv) Which is not part of a Publicly Owned Treatment Works (POTW) as defined at 40 CFR 122.2.

**National Pollutant Discharge Elimination System (NPDES)** - means the national system for the issuance of wastewater and stormwater permits under the Federal Water Pollution Control Act (Clean Water Act).

**New Development** – means any land disturbance that does meet the definition of Redevelopment Activity included in this appendix.

**NOI Acknowledgment Letter** - means the letter that the Department sends to an owner or operator to acknowledge the Department's receipt and acceptance of a complete Notice of Intent. This letter documents the owner's or operator's authorization to discharge in accordance with the general permit for stormwater discharges from *construction activity*.

**Owner or Operator** - means the person, persons or legal entity which owns or leases the property on which the *construction activity* is occurring; and/or an entity that has operational control over the construction plans and specifications, including the ability to make modifications to the plans and specifications.

**Performance Criteria** – means the design criteria listed under the “Required Elements” sections in Chapters 5, 6 and 10 of the technical standard, New York State Stormwater Management Design Manual, dated January 2015. It does not include the Sizing Criteria (i.e. WQv, RRv, Cpv, Qp and Qf ) in Part I.C.2. of the permit.

**Pollutant** - means dredged spoil, filter backwash, solid waste, incinerator residue, sewage, garbage, sewage sludge, munitions, chemical wastes, biological materials, radioactive materials, heat, wrecked or discarded equipment, rock, sand and industrial, municipal, agricultural waste and ballast discharged into water; which may cause or might reasonably be expected to cause pollution of the waters of the state in contravention of the standards or guidance values adopted as provided in 6 NYCRR Parts 700 et seq .

**Qualified Inspector** - means a person that is knowledgeable in the principles and practices of erosion and sediment control, such as a licensed Professional Engineer, Certified Professional in Erosion and Sediment Control (CPESC), Registered Landscape Architect, or other Department endorsed individual(s).

It can also mean someone working under the direct supervision of, and at the same company as, the licensed Professional Engineer or Registered Landscape Architect, provided that person has training in the principles and practices of erosion and sediment control. Training in the principles and practices of erosion and sediment control means that the individual working under the direct supervision of the licensed Professional Engineer or Registered Landscape Architect has received four (4) hours of Department endorsed training in proper erosion and sediment control principles from a Soil and Water Conservation District, or other Department endorsed entity. After receiving the initial training, the individual working under the direct supervision of the licensed Professional Engineer or Registered Landscape Architect shall receive four (4) hours of training every three (3) years.

It can also mean a person that meets the *Qualified Professional* qualifications in addition to the *Qualified Inspector* qualifications.

Note: Inspections of any post-construction stormwater management practices that include structural components, such as a dam for an impoundment, shall be performed by a licensed Professional Engineer.

**Qualified Professional** - means a person that is knowledgeable in the principles and practices of stormwater management and treatment, such as a licensed Professional Engineer, Registered Landscape Architect or other Department endorsed individual(s). Individuals preparing SWPPPs that require the post-construction stormwater management practice component must have an understanding of the principles of hydrology, water quality management practice design, water quantity control design, and, in many cases, the principles of hydraulics. All components of the SWPPP that involve the practice of engineering, as defined by the NYS Education Law (see Article 145), shall be prepared by, or under the direct supervision of, a professional engineer licensed to practice in the State of New York..

**Redevelopment Activity(ies)** – means the disturbance and reconstruction of existing impervious area, including impervious areas that were removed from a project site within five (5) years of preliminary project plan submission to the local government (i.e. site plan, subdivision, etc.).

**Regulated, Traditional Land Use Control MS4** - means a city, town or village with land use control authority that is required to gain coverage under New York State DEC's SPDES General Permit For Stormwater Discharges from Municipal Separate Stormwater Sewer Systems (MS4s).

**Routine Maintenance Activity** - means *construction activity* that is performed to maintain the original line and grade, hydraulic capacity, or original purpose of a facility, including, but not limited to:

- Re-grading of gravel roads or parking lots,
- Stream bank restoration projects (does not include the placement of spoil material),
- Cleaning and shaping of existing roadside ditches and culverts that maintains the approximate original line and grade, and hydraulic capacity of the ditch,
- Cleaning and shaping of existing roadside ditches that does not maintain the approximate original grade, hydraulic capacity and purpose of the ditch if the changes to the line and grade, hydraulic capacity or purpose of the ditch are installed to improve water quality and quantity controls (e.g. installing grass lined ditch),
- Placement of aggregate shoulder backing that makes the transition between the road shoulder and the ditch or embankment,
- Full depth milling and filling of existing asphalt pavements, replacement of concrete pavement slabs, and similar work that does not expose soil or disturb the bottom six (6) inches of subbase material,
- Long-term use of equipment storage areas at or near highway maintenance facilities,
- Removal of sediment from the edge of the highway to restore a previously existing sheet-flow drainage connection from the highway surface to the highway ditch or embankment,
- Existing use of Canal Corp owned upland disposal sites for the canal, and
- Replacement of curbs, gutters, sidewalks and guide rail posts.

**Site limitations** – means site conditions that prevent the use of an infiltration technique and or infiltration of the total WQv. Typical site limitations include: seasonal high groundwater, shallow depth to bedrock, and soils with an infiltration rate less than 0.5 inches/hour. The existence of site limitations shall be confirmed and documented using actual field testing (i.e. test pits, soil borings, and infiltration test) or using information from the most current United States Department of Agriculture (USDA) Soil Survey for the County where the project is located.

**Sizing Criteria** – means the criteria included in Part I.C.2 of the permit that are used to size post-construction stormwater management control practices. The criteria include; Water Quality Volume (WQv), Runoff Reduction Volume (RRv), Channel Protection Volume (Cpv), Overbank Flood (Qp), and Extreme Flood (Qf).

**State Pollutant Discharge Elimination System (SPDES)** - means the system established pursuant to Article 17 of the ECL and 6 NYCRR Part 750 for issuance of permits authorizing discharges to the waters of the state.

**Steep Slope** – means land area with a Soil Slope Phase that is identified as an E or F, or

the map unit name is inclusive of 25% or greater slope, on the United States Department of Agriculture (“USDA”) Soil Survey for the County where the disturbance will occur.

**Surface Waters of the State** - shall be construed to include lakes, bays, sounds, ponds, impounding reservoirs, springs, rivers, streams, creeks, estuaries, marshes, inlets, canals, the Atlantic ocean within the territorial seas of the state of New York and all other bodies of surface water, natural or artificial, inland or coastal, fresh or salt, public or private (except those private waters that do not combine or effect a junction with natural surface waters), which are wholly or partially within or bordering the state or within its jurisdiction. Waters of the state are further defined in 6 NYCRR Parts 800 to 941.

**Temporarily Ceased** – means that an existing disturbed area will not be disturbed again within 14 calendar days of the previous soil disturbance.

**Temporary Stabilization** - means that exposed soil has been covered with material(s) as set forth in the technical standard, New York Standards and Specifications for Erosion and Sediment Control, to prevent the exposed soil from eroding. The materials can include, but are not limited to, mulch, seed and mulch, and erosion control mats (e.g. jute twisted yarn, excelsior wood fiber mats).

**Total Maximum Daily Loads (TMDLs)** - A TMDL is the sum of the allowable loads of a single pollutant from all contributing point and nonpoint sources. It is a calculation of the maximum amount of a pollutant that a waterbody can receive on a daily basis and still meet *water quality standards*, and an allocation of that amount to the pollutant's sources. A TMDL stipulates wasteload allocations (WLAs) for point source discharges, load allocations (LAs) for nonpoint sources, and a margin of safety (MOS).

**Trained Contractor** - means an employee from the contracting (construction) company, identified in Part III.A.6., that has received four (4) hours of Department endorsed training in proper erosion and sediment control principles from a Soil and Water Conservation District, or other Department endorsed entity. After receiving the initial training, the *trained contractor* shall receive four (4) hours of training every three (3) years.

It can also mean an employee from the contracting (construction) company, identified in Part III.A.6., that meets the *qualified inspector* qualifications (e.g. licensed Professional Engineer, Certified Professional in Erosion and Sediment Control (CPESC), Registered Landscape Architect, or someone working under the direct supervision of, and at the same company as, the licensed Professional Engineer or Registered Landscape Architect, provided they have received four (4) hours of Department endorsed training in proper erosion and sediment control principles from a Soil and Water Conservation District, or other Department endorsed entity).

The *trained contractor* is responsible for the day to day implementation of the SWPPP.

**Uniform Procedures Act (UPA) Permit** - means a permit required under 6 NYCRR Part



621 of the Environmental Conservation Law (ECL), Article 70.

**Water Quality Standard** - means such measures of purity or quality for any waters in relation to their reasonable and necessary use as promulgated in 6 NYCRR Part 700 et seq.

IX. APPENDIX B

**Required SWPPP Components by Project Type**

**Table 1  
CONSTRUCTION ACTIVITIES THAT REQUIRE THE PREPARATION OF A SWPPP  
THAT ONLY INCLUDES EROSION AND SEDIMENT CONTROLS**

<p><b>The following construction activities that involve soil disturbances of one (1) or more acres of land, but less than five (5) acres:</b></p> <ul style="list-style-type: none"> <li>• Single family home <u>not</u> located in one of the watersheds listed in Appendix C or <u>not directly discharging</u> to one of the 303(d) segments listed in Appendix E</li> <li>• Single family residential subdivisions with 25% or less impervious cover at total site build-out and <u>not</u> located in one of the watersheds listed in Appendix C and <u>not</u> directly discharging to one of the 303(d) segments listed in Appendix E</li> <li>• Construction of a barn or other agricultural building, silo, stock yard or pen.</li> </ul>
<p><b>The following construction activities that involve soil disturbances of one (1) or more acres of land:</b></p> <ul style="list-style-type: none"> <li>• Installation of underground, linear utilities; such as gas lines, fiber-optic cable, cable TV, electric, telephone, sewer mains, and water mains</li> <li>• Environmental enhancement projects, such as wetland mitigation projects, stormwater retrofits and stream restoration projects</li> <li>• Bike paths and trails</li> <li>• Sidewalk construction projects that are not part of a road/ highway construction or reconstruction project</li> <li>• Slope stabilization projects</li> <li>• Slope flattening that changes the grade of the site, but does not significantly change the runoff characteristics</li> <li>• Spoil areas that will be covered with vegetation</li> <li>• Land clearing and grading for the purposes of creating vegetated open space (i.e. recreational parks, lawns, meadows, fields), excluding projects that <i>alter hydrology from pre to post development</i> conditions</li> <li>• Athletic fields (natural grass) that do not include the construction or reconstruction of <i>impervious area</i> <u>and</u> do not <i>alter hydrology from pre to post development</i> conditions</li> <li>• Demolition project where vegetation will be established and no redevelopment is planned</li> <li>• Overhead electric transmission line project that does not include the construction of permanent access roads or parking areas surfaced with <i>impervious cover</i></li> <li>• Structural practices as identified in Table II in the “Agricultural Management Practices Catalog for Nonpoint Source Pollution in New York State”, excluding projects that involve soil disturbances of less than five acres and construction activities that include the construction or reconstruction of impervious area</li> </ul>
<p><b>The following construction activities that involve soil disturbances between five thousand (5000) square feet and one (1) acre of land:</b></p> <ul style="list-style-type: none"> <li>• All construction activities located in the watersheds identified in Appendix D that involve soil disturbances between five thousand (5,000) square feet and one (1) acre of land.</li> </ul>

**Table 2**  
**CONSTRUCTION ACTIVITIES THAT REQUIRE THE PREPARATION OF A SWPPP THAT INCLUDES**  
**POST-CONSTRUCTION STORMWATER MANAGEMENT PRACTICES**

**The following construction activities that involve soil disturbances of one (1) or more acres of land:**

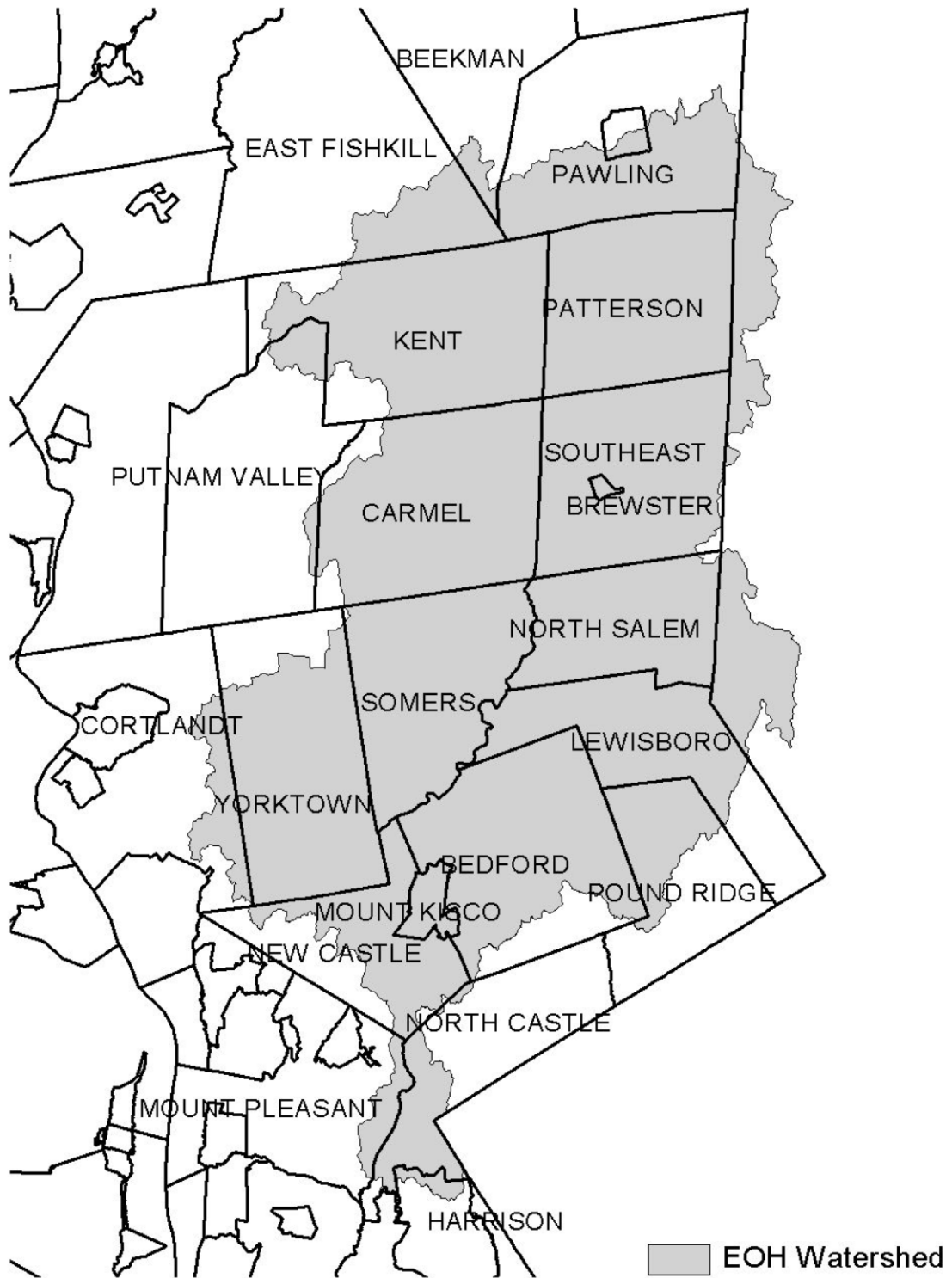
- Single family home located in one of the watersheds listed in Appendix C or *directly discharging* to one of the 303(d) segments listed in Appendix E
- Single family residential subdivisions located in one of the watersheds listed in Appendix C or *directly discharging* to one of the 303(d) segments listed in Appendix E
- Single family residential subdivisions that involve soil disturbances of between one (1) and five (5) acres of land with greater than 25% impervious cover at total site build-out
- Single family residential subdivisions that involve soil disturbances of five (5) or more acres of land, and single family residential subdivisions that involve soil disturbances of less than five (5) acres that are part of a larger common plan of development or sale that will ultimately disturb five or more acres of land
- Multi-family residential developments; includes townhomes, condominiums, senior housing complexes, apartment complexes, and mobile home parks
- Airports
- Amusement parks
- Campgrounds
- Cemeteries that include the construction or reconstruction of impervious area (>5% of disturbed area) or *alter the hydrology from pre to post development* conditions
- Commercial developments
- Churches and other places of worship
- Construction of a barn or other agricultural building(e.g. silo) and structural practices as identified in Table II in the “Agricultural Management Practices Catalog for Nonpoint Source Pollution in New York State” that include the construction or reconstruction of *impervious area*, excluding projects that involve soil disturbances of less than five acres.
- Golf courses
- Institutional, includes hospitals, prisons, schools and colleges
- Industrial facilities, includes industrial parks
- Landfills
- Municipal facilities; includes highway garages, transfer stations, office buildings, POTW’s and water treatment plants
- Office complexes
- Sports complexes
- Racetracks, includes racetracks with earthen (dirt) surface
- Road construction or reconstruction
- Parking lot construction or reconstruction
- Athletic fields (natural grass) that include the construction or reconstruction of impervious area (>5% of disturbed area) or *alter the hydrology from pre to post development* conditions
- Athletic fields with artificial turf
- Permanent access roads, parking areas, substations, compressor stations and well drilling pads, surfaced with *impervious cover*, and constructed as part of an over-head electric transmission line project , wind-power project, cell tower project, oil or gas well drilling project, sewer or water main project or other linear utility project
- All other construction activities that include the construction or reconstruction of *impervious area* or *alter the hydrology from pre to post development* conditions, and are not listed in Table 1

**APPENDIX C****Watersheds Where Enhanced Phosphorus Removal Standards Are Required**

**Watersheds where *owners or operators* of construction activities identified in Table 2 of Appendix B must prepare a SWPPP that includes post-construction stormwater management practices designed in conformance with the Enhanced Phosphorus Removal Standards included in the technical standard, New York State Stormwater Management Design Manual (“Design Manual”).**

- Entire New York City Watershed located east of the Hudson River - Figure 1
- Onondaga Lake Watershed - Figure 2
- Greenwood Lake Watershed -Figure 3
- Oscawana Lake Watershed – Figure 4
- Kinderhook Lake Watershed – Figure 5

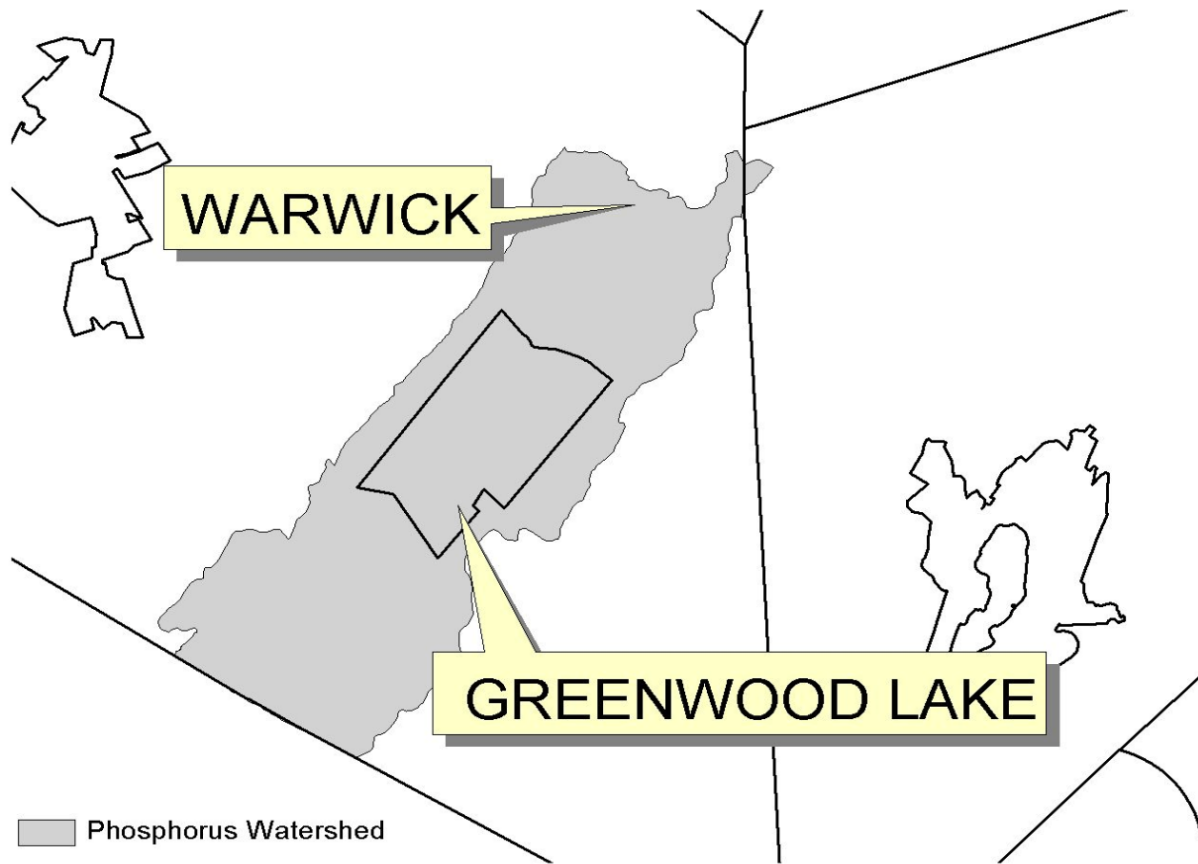
**Figure 1 - New York City Watershed East of the Hudson**



**Figure 2 - Onondaga Lake Watershed**



**Figure 3 - Greenwood Lake Watershed**



**Figure 4 - Oscawana Lake Watershed**

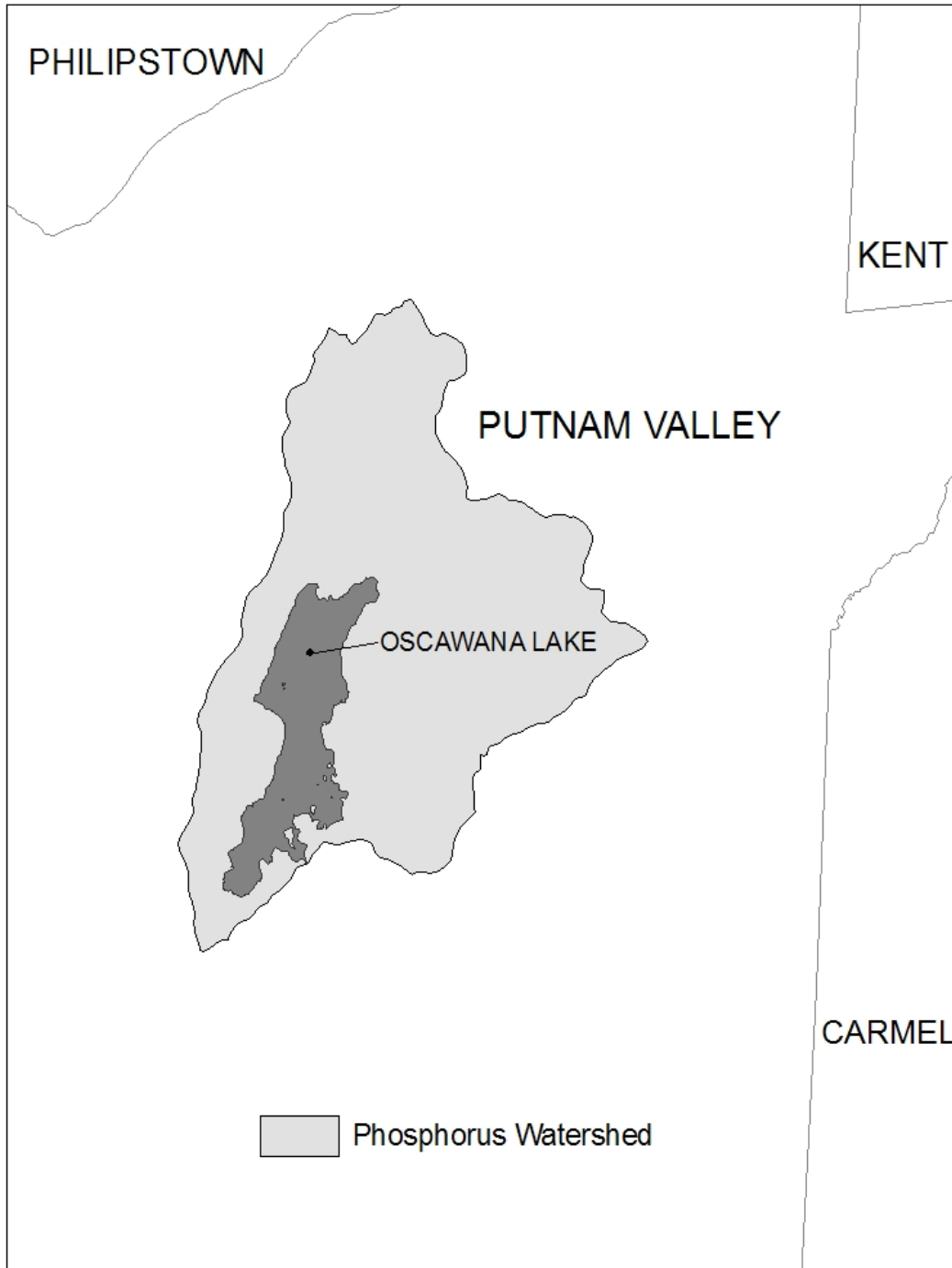
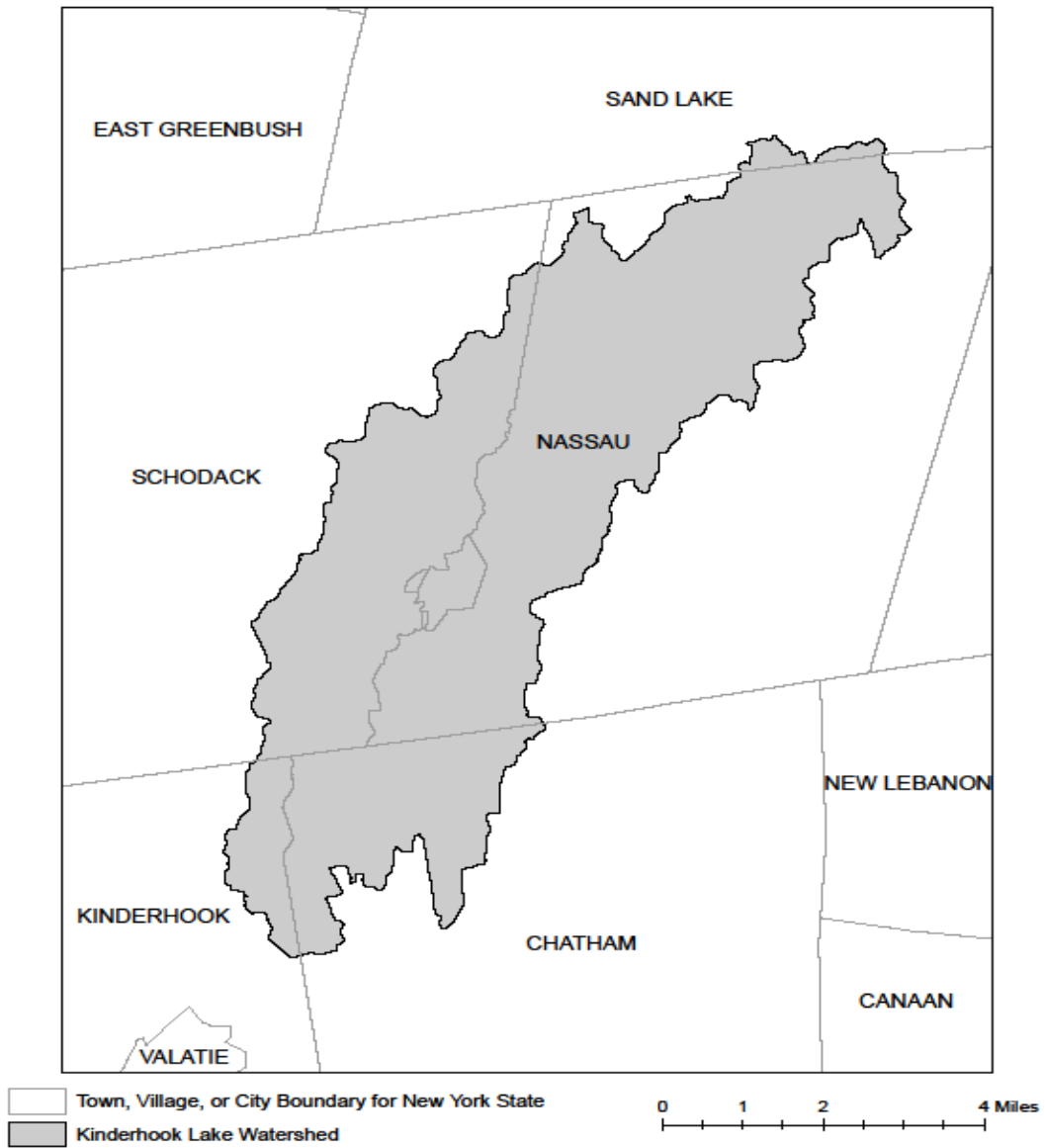




Figure 5: Kinderhook Lake Watershed



XI. **APPENDIX D**

**Watersheds where *owners or operators* of construction activities that involve soil disturbances between five thousand (5000) square feet and one (1) acre of land must obtain coverage under this permit.**

Entire New York City Watershed that is located east of the Hudson River - See Figure 1 in Appendix C

XII. APPENDIX E

List of 303(d) segments impaired by pollutants related to *construction activity* (e.g. silt, sediment or nutrients). *Owners or operators* of single family home and single family residential subdivisions with 25% or less total impervious cover at total site build-out that involve soil disturbances of one or more acres of land, but less than 5 acres, and *directly discharge* to one of the listed segments below shall prepare a SWPPP that includes post-construction stormwater management practices designed in conformance with the New York State Stormwater Management Design Manual (“Design Manual”), dated January 2015.

COUNTY	WATERBODY	COUNTY	WATERBODY
Albany	Ann Lee (Shakers) Pond, Stump Pond	Greene	Sleepy Hollow Lake
Albany	Basic Creek Reservoir	Herkimer	Steele Creek tribs
Allegheny	Amity Lake, Saunders Pond	Kings	Hendrix Creek
Bronx	Van Cortlandt Lake	Lewis	Mill Creek/South Branch and tribs
Broome	Whitney Point Lake/Reservoir	Livingston	Conesus Lake
Broome	Fly Pond, Deer Lake	Livingston	Jaycox Creek and tribs
Broome	Minor Tribs to Lower Susquehanna (north)	Livingston	Mill Creek and minor tribs
Cattaraugus	Allegheny River/Reservoir	Livingston	Bradner Creek and tribs
Cattaraugus	Case Lake	Livingston	Christie Creek and tribs
Cattaraugus	Linlyco/Club Pond	Monroe	Lake Ontario Shoreline, Western
Cayuga	Duck Lake	Monroe	Mill Creek/Blue Pond Outlet and tribs
Chautauqua	Chautauqua Lake, North	Monroe	Rochester Embayment - East
Chautauqua	Chautauqua Lake, South	Monroe	Rochester Embayment - West
Chautauqua	Bear Lake	Monroe	Unnamed Trib to Honeoye Creek
Chautauqua	Chadakoin River and tribs	Monroe	Genesee River, Lower, Main Stem
Chautauqua	Lower Cassadaga Lake	Monroe	Genesee River, Middle, Main Stem
Chautauqua	Middle Cassadaga Lake	Monroe	Black Creek, Lower, and minor tribs
Chautauqua	Findley Lake	Monroe	Buck Pond
Clinton	Great Chazy River, Lower, Main Stem	Monroe	Long Pond
Columbia	Kinderhook Lake	Monroe	Cranberry Pond
Columbia	Robinson Pond	Monroe	Mill Creek and tribs
Dutchess	Hillside Lake	Monroe	Shipbuilders Creek and tribs
Dutchess	Wappinger Lakes	Monroe	Minor tribs to Irondequoit Bay
Dutchess	Fall Kill and tribs	Monroe	Thomas Creek/White Brook and tribs
Erie	Green Lake	Nassau	Glen Cove Creek, Lower, and tribs
Erie	Scajaquada Creek, Lower, and tribs	Nassau	LI Tribs (fresh) to East Bay
Erie	Scajaquada Creek, Middle, and tribs	Nassau	East Meadow Brook, Upper, and tribs
Erie	Scajaquada Creek, Upper, and tribs	Nassau	Hempstead Bay
Erie	Rush Creek and tribs	Nassau	Hempstead Lake
Erie	Ellicott Creek, Lower, and tribs	Nassau	Grant Park Pond
Erie	Beeman Creek and tribs	Nassau	Beaver Lake
Erie	Murder Creek, Lower, and tribs	Nassau	Camaans Pond
Erie	South Branch Smoke Cr, Lower, and tribs	Nassau	Halls Pond
Erie	Little Sister Creek, Lower, and tribs	Nassau	LI Tidal Tribs to Hempstead Bay
Essex	Lake George (primary county: Warren)	Nassau	Massapequa Creek and tribs
Genesee	Black Creek, Upper, and minor tribs	Nassau	Reynolds Channel, east
Genesee	Tonawanda Creek, Middle, Main Stem	Nassau	Reynolds Channel, west
Genesee	Oak Orchard Creek, Upper, and tribs	Nassau	Silver Lake, Lofts Pond
Genesee	Bowen Brook and tribs	Nassau	Woodmere Channel
Genesee	Bigelow Creek and tribs	Niagara	Hyde Park Lake
Genesee	Black Creek, Middle, and minor tribs	Niagara	Lake Ontario Shoreline, Western
Genesee	LeRoy Reservoir	Niagara	Bergholtz Creek and tribs
Greene	Schoharie Reservoir	Oneida	Ballou, Nail Creeks
		Onondaga	Ley Creek and tribs
		Onondaga	Onondaga Creek, Lower and tribs

## APPENDIX E

### List of 303(d) segments impaired by pollutants related to construction activity, cont'd.

COUNTY	WATERBODY	COUNTY	WATERBODY
Onondaga	Onondaga Creek, Middle and tribs	Suffolk	Great South Bay, West
Onondaga	Onondaga Creek, Upp, and minor tribs	Suffolk	Mill and Seven Ponds
Onondaga	Harbor Brook, Lower, and tribs	Suffolk	Moriches Bay, East
Onondaga	Ninemile Creek, Lower, and tribs	Suffolk	Moriches Bay, West
Onondaga	Minor tribs to Onondaga Lake	Suffolk	Quantuck Bay
Onondaga	Onondaga Creek, Lower, and tribs	Suffolk	Shinnecock Bay (and Inlet)
Ontario	Honeoye Lake	Sullivan	Bodine, Montgomery Lakes
Ontario	Hemlock Lake Outlet and minor tribs	Sullivan	Davies Lake
Ontario	Great Brook and minor tribs	Sullivan	Pleasure Lake
Orange	Monhagen Brook and tribs	Sullivan	Swan Lake
Orange	Orange Lake	Tompkins	Cayuga Lake, Southern End
Orleans	Lake Ontario Shoreline, Western	Tompkins	Owasco Inlet, Upper, and tribs
Oswego	Pleasant Lake	Ulster	Ashokan Reservoir
Oswego	Lake Neatahwanta	Ulster	Esopus Creek, Upper, and minor tribs
Putnam	Oscawana Lake	Ulster	Esopus Creek, Lower, Main Stem
Putnam	Palmer Lake	Ulster	Esopus Creek, Middle, and minor tribs
Putnam	Lake Carmel	Warren	Lake George
Queens	Jamaica Bay, Eastern, and tribs (Queens)	Warren	Tribs to L.George, Village of L George
Queens	Bergen Basin	Warren	Huddle/Finkle Brooks and tribs
Queens	Shellbank Basin	Warren	Indian Brook and tribs
Rensselaer	Nassau Lake	Warren	Hague Brook and tribs
Rensselaer	Snyders Lake	Washington	Tribs to L.George, East Shr Lk George
Richmond	Grasmere, Arbutus and Wolfes Lakes	Washington	Cossayuna Lake
Rockland	Congers Lake, Swartout Lake	Washington	Wood Cr/Champlain Canal, minor tribs
Rockland	Rockland Lake	Wayne	Port Bay
Saratoga	Ballston Lake	Wayne	Marbletown Creek and tribs
Saratoga	Round Lake	Westchester	Lake Katonah
Saratoga	Dwaas Kill and tribs	Westchester	Lake Mohegan
Saratoga	Tribs to Lake Lonely	Westchester	Lake Shenorock
Saratoga	Lake Lonely	Westchester	Reservoir No.1 (Lake Isle)
Schenectady	Collins Lake	Westchester	Saw Mill River, Middle, and tribs
Schenectady	Duane Lake	Westchester	Silver Lake
Schenectady	Mariaville Lake	Westchester	Teatown Lake
Schoharie	Engleville Pond	Westchester	Truesdale Lake
Schoharie	Summit Lake	Westchester	Wallace Pond
Schuyler	Cayuta Lake	Westchester	Peach Lake
St. Lawrence	Fish Creek and minor tribs	Westchester	Mamaroneck River, Lower
St. Lawrence	Black Lake Outlet/Black Lake	Westchester	Mamaroneck River, Upp, and tribs
Steuben	Lake Salubria	Westchester	Sheldrake River and tribs
Steuben	Smith Pond	Westchester	Blind Brook, Lower
Suffolk	Millers Pond	Westchester	Blind Brook, Upper, and tribs
Suffolk	Mattituck (Marratooka) Pond	Westchester	Lake Lincolndale
Suffolk	Tidal tribs to West Moriches Bay	Westchester	Lake Meahaugh
Suffolk	Canaan Lake	Wyoming	Java Lake
Suffolk	Lake Ronkonkoma	Wyoming	Silver Lake
Suffolk	Beaverdam Creek and tribs		
Suffolk	Big/Little Fresh Ponds		
Suffolk	Fresh Pond		
Suffolk	Great South Bay, East		
Suffolk	Great South Bay, Middle		

Note: The list above identifies those waters from the final New York State "2014 Section 303(d) List of Impaired Waters Requiring a TMDL/Other Strategy", dated January 2015, that are impaired by silt, sediment or nutrients.

XIII. APPENDIX F

**LIST OF NYS DEC REGIONAL OFFICES**

<b><u>Region</u></b>	<b><u>COVERING THE FOLLOWING COUNTIES:</u></b>	<b><u>DIVISION OF ENVIRONMENTAL PERMITS (DEP) PERMIT ADMINISTRATORS</u></b>	<b><u>DIVISION OF WATER (DOW) WATER (SPDES) PROGRAM</u></b>
<b>1</b>	NASSAU AND SUFFOLK	50 CIRCLE ROAD STONY BROOK, NY 11790 TEL. (631) 444-0365	50 CIRCLE ROAD STONY BROOK, NY 11790-3409 TEL. (631) 444-0405
<b>2</b>	BRONX, KINGS, NEW YORK, QUEENS AND RICHMOND	1 HUNTERS POINT PLAZA, 47-40 21ST ST. LONG ISLAND CITY, NY 11101-5407 TEL. (718) 482-4997	1 HUNTERS POINT PLAZA, 47-40 21ST ST. LONG ISLAND CITY, NY 11101-5407 TEL. (718) 482-4933
<b>3</b>	DUTCHESS, ORANGE, PUTNAM, ROCKLAND, SULLIVAN, ULSTER AND WESTCHESTER	21 SOUTH PUTT CORNERS ROAD NEW PALTZ, NY 12561-1696 TEL. (845) 256-3059	100 HILLSIDE AVENUE, SUITE 1W WHITE PLAINS, NY 10603 TEL. (914) 428 - 2505
<b>4</b>	ALBANY, COLUMBIA, DELAWARE, GREENE, MONTGOMERY, OTSEGO, RENSSELAER, SCHENECTADY AND SCHOHARIE	1150 NORTH WESTCOTT ROAD SCHENECTADY, NY 12306-2014 TEL. (518) 357-2069	1130 NORTH WESTCOTT ROAD SCHENECTADY, NY 12306-2014 TEL. (518) 357-2045
<b>5</b>	CLINTON, ESSEX, FRANKLIN, FULTON, HAMILTON, SARATOGA, WARREN AND WASHINGTON	1115 STATE ROUTE 86, Po Box 296 RAY BROOK, NY 12977-0296 TEL. (518) 897-1234	232 GOLF COURSE ROAD WARRENSBURG, NY 12885-1172 TEL. (518) 623-1200
<b>6</b>	HERKIMER, JEFFERSON, LEWIS, ONEIDA AND ST. LAWRENCE	STATE OFFICE BUILDING 317 WASHINGTON STREET WATERTOWN, NY 13601-3787 TEL. (315) 785-2245	STATE OFFICE BUILDING 207 GENESEE STREET UTICA, NY 13501-2885 TEL. (315) 793-2554
<b>7</b>	BROOME, CAYUGA, CHENANGO, CORTLAND, MADISON, ONONDAGA, OSWEGO, TIOGA AND TOMPKINS	615 ERIE BLVD. WEST SYRACUSE, NY 13204-2400 TEL. (315) 426-7438	615 ERIE BLVD. WEST SYRACUSE, NY 13204-2400 TEL. (315) 426-7500
<b>8</b>	CHEMUNG, GENESEE, LIVINGSTON, MONROE, ONTARIO, ORLEANS, SCHUYLER, SENECA, STEUBEN, WAYNE AND YATES	6274 EAST AVON-LIMA ROAD AVON, NY 14414-9519 TEL. (585) 226-2466	6274 EAST AVON-LIMA RD. AVON, NY 14414-9519 TEL. (585) 226-2466
<b>9</b>	ALLEGANY, CATTARAUGUS, CHAUTAUQUA, ERIE, NIAGARA AND WYOMING	270 MICHIGAN AVENUE BUFFALO, NY 14203-2999 TEL. (716) 851-7165	270 MICHIGAN AVE. BUFFALO, NY 14203-2999 TEL. (716) 851-7070





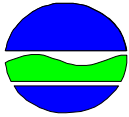
## Appendix E

# Notice of Intent (NOI)





# NOTICE OF INTENT



**New York State Department of Environmental Conservation  
Division of Water  
625 Broadway, 4th Floor  
Albany, New York 12233-3505**

**NYR**   
(for DEC use only)

**Stormwater Discharges Associated with Construction Activity Under State Pollutant Discharge Elimination System (SPDES) General Permit # GP-0-15-002**  
All sections must be completed unless otherwise noted. Failure to complete all items may result in this form being returned to you, thereby delaying your coverage under this General Permit. Applicants must read and understand the conditions of the permit and prepare a Stormwater Pollution Prevention Plan prior to submitting this NOI. Applicants are responsible for identifying and obtaining other DEC permits that may be required.

**- IMPORTANT -**  
**RETURN THIS FORM TO THE ADDRESS ABOVE**  
**OWNER/OPERATOR MUST SIGN FORM**

### Owner/Operator Information

Owner/Operator (Company Name/Private Owner Name/Municipality Name)

Owner/Operator Contact Person Last Name (NOT CONSULTANT)

Owner/Operator Contact Person First Name

Owner/Operator Mailing Address

City

State  Zip  -

Phone (Owner/Operator)  -  -  Fax (Owner/Operator)  -  -

Email (Owner/Operator)

FED TAX ID  -  (not required for individuals)



3. Select the predominant land use for both pre and post development conditions.  
**SELECT ONLY ONE CHOICE FOR EACH**

**Pre-Development  
Existing Land Use**

- FOREST
- PASTURE/OPEN LAND
- CULTIVATED LAND
- SINGLE FAMILY HOME
- SINGLE FAMILY SUBDIVISION
- TOWN HOME RESIDENTIAL
- MULTIFAMILY RESIDENTIAL
- INSTITUTIONAL/SCHOOL
- INDUSTRIAL
- COMMERCIAL
- ROAD/HIGHWAY
- RECREATIONAL/SPORTS FIELD
- BIKE PATH/TRAIL
- LINEAR UTILITY
- PARKING LOT
- OTHER

--	--	--	--	--	--	--	--	--	--	--	--	--	--	--	--	--	--	--	--	--

**Post-Development  
Future Land Use**

- SINGLE FAMILY HOME
- SINGLE FAMILY SUBDIVISION
- TOWN HOME RESIDENTIAL
- MULTIFAMILY RESIDENTIAL
- INSTITUTIONAL/SCHOOL
- INDUSTRIAL
- COMMERCIAL
- MUNICIPAL
- ROAD/HIGHWAY
- RECREATIONAL/SPORTS FIELD
- BIKE PATH/TRAIL
- LINEAR UTILITY (water, sewer, gas, etc.)
- PARKING LOT
- CLEARING/GRADING ONLY
- DEMOLITION, NO REDEVELOPMENT
- WELL DRILLING ACTIVITY \*(Oil, Gas, etc.)
- OTHER

Number of Lots

--	--	--

--	--	--	--	--	--	--	--	--	--	--	--	--	--	--	--	--	--	--	--	--

**\*Note:** for gas well drilling, non-high volume hydraulic fractured wells only

4. In accordance with the larger common plan of development or sale, enter the total project site area; the total area to be disturbed; existing impervious area to be disturbed (for redevelopment activities); and the future impervious area constructed within the disturbed area. (Round to the nearest tenth of an acre.)

Total Site Area	Total Area To Be Disturbed	Existing Impervious Area To Be Disturbed	Future Impervious Area Within Disturbed Area																				
<table border="1" style="width: 60px; height: 25px;"> <tr> <td></td><td></td><td></td><td></td><td></td> </tr> </table>						<table border="1" style="width: 60px; height: 25px;"> <tr> <td></td><td></td><td></td><td></td><td></td> </tr> </table>						<table border="1" style="width: 60px; height: 25px;"> <tr> <td></td><td></td><td></td><td></td><td></td> </tr> </table>						<table border="1" style="width: 60px; height: 25px;"> <tr> <td></td><td></td><td></td><td></td><td></td> </tr> </table>					

5. Do you plan to disturb more than 5 acres of soil at any one time?  Yes  No

6. Indicate the percentage of each Hydrologic Soil Group(HSG) at the site.

<p><b>A</b></p> <table border="1" style="width: 40px; height: 25px;"> <tr> <td></td><td></td><td></td> </tr> </table> <p>%</p>				<p><b>B</b></p> <table border="1" style="width: 40px; height: 25px;"> <tr> <td></td><td></td><td></td> </tr> </table> <p>%</p>				<p><b>C</b></p> <table border="1" style="width: 40px; height: 25px;"> <tr> <td></td><td></td><td></td> </tr> </table> <p>%</p>				<p><b>D</b></p> <table border="1" style="width: 40px; height: 25px;"> <tr> <td></td><td></td><td></td> </tr> </table> <p>%</p>			

7. Is this a phased project?  Yes  No

8. Enter the planned start and end dates of the disturbance activities.

<b>Start Date</b>		<b>End Date</b>	
	/		/
	/		/
		-	
	/		/
	/		/



15. Does the site runoff enter a separate storm sewer system (including roadside drains, swales, ditches, culverts, etc)?  Yes  No  Unknown

16. What is the name of the municipality/entity that owns the separate storm sewer system?

Two rows of empty grid boxes for text entry.

17. Does any runoff from the site enter a sewer classified as a Combined Sewer?  Yes  No  Unknown

18. Will future use of this site be an agricultural property as defined by the NYS Agriculture and Markets Law?  Yes  No

19. Is this property owned by a state authority, state agency, federal government or local government?  Yes  No

20. Is this a remediation project being done under a Department approved work plan? (i.e. CERCLA, RCRA, Voluntary Cleanup Agreement, etc.)  Yes  No

21. Has the required Erosion and Sediment Control component of the SWPPP been developed in conformance with the current NYS Standards and Specifications for Erosion and Sediment Control (aka Blue Book)?  Yes  No

22. Does this construction activity require the development of a SWPPP that includes the post-construction stormwater management practice component (i.e. Runoff Reduction, Water Quality and Quantity Control practices/techniques)?  Yes  No  
**If No, skip questions 23 and 27-39.**

23. Has the post-construction stormwater management practice component of the SWPPP been developed in conformance with the current NYS Stormwater Management Design Manual?  Yes  No





**Post-construction Stormwater Management Practice (SMP) Requirements**

**Important: Completion of Questions 27-39 is not required if response to Question 22 is No.**

27. Identify all site planning practices that were used to prepare the final site plan/layout for the project.

- Preservation of Undisturbed Areas
- Preservation of Buffers
- Reduction of Clearing and Grading
- Locating Development in Less Sensitive Areas
- Roadway Reduction
- Sidewalk Reduction
- Driveway Reduction
- Cul-de-sac Reduction
- Building Footprint Reduction
- Parking Reduction

27a. Indicate which of the following soil restoration criteria was used to address the requirements in Section 5.1.6("Soil Restoration") of the Design Manual (2010 version).

- All disturbed areas will be restored in accordance with the Soil Restoration requirements in Table 5.3 of the Design Manual (see page 5-22).
- Compacted areas were considered as impervious cover when calculating the **WQv Required**, and the compacted areas were assigned a post-construction Hydrologic Soil Group (HSG) designation that is one level less permeable than existing conditions for the hydrology analysis.

28. Provide the total Water Quality Volume (WQv) required for this project (based on final site plan/layout).

**Total WQv Required**

.  acre-feet

29. Identify the RR techniques (Area Reduction), RR techniques (Volume Reduction) and Standard SMPs with RRv Capacity in Table 1 (See Page 9) that were used to reduce the Total WQv Required (#28).

Also, provide in Table 1 the total impervious area that contributes runoff to each technique/practice selected. For the Area Reduction Techniques, provide the total contributing area (includes pervious area) and, if applicable, the total impervious area that contributes runoff to the technique/practice.

**Note:** Redevelopment projects shall use Tables 1 and 2 to identify the SMPs used to treat and/or reduce the WQv required. If runoff reduction techniques will not be used to reduce the required WQv, skip to question 33a after identifying the SMPs.



Table 1 - Runoff Reduction (RR) Techniques and Standard Stormwater Management Practices (SMPs)

<u>RR Techniques (Area Reduction)</u>	<u>Total Contributing Area (acres)</u>		<u>Total Contributing Impervious Area(acres)</u>	
<input type="radio"/> Conservation of Natural Areas (RR-1) ...	<input type="text"/>	<input type="text"/>	and/or	<input type="text"/>
<input type="radio"/> Sheetflow to Riparian Buffers/Filters Strips (RR-2) .....	<input type="text"/>	<input type="text"/>	and/or	<input type="text"/>
<input type="radio"/> Tree Planting/Tree Pit (RR-3) .....	<input type="text"/>	<input type="text"/>	and/or	<input type="text"/>
<input type="radio"/> Disconnection of Rooftop Runoff (RR-4) ..	<input type="text"/>	<input type="text"/>	and/or	<input type="text"/>
<u>RR Techniques (Volume Reduction)</u>				
<input type="radio"/> Vegetated Swale (RR-5) .....				
<input type="radio"/> Rain Garden (RR-6) .....				
<input type="radio"/> Stormwater Planter (RR-7) .....				
<input type="radio"/> Rain Barrel/Cistern (RR-8) .....				
<input type="radio"/> Porous Pavement (RR-9) .....				
<input type="radio"/> Green Roof (RR-10) .....				
<u>Standard SMPs with RRv Capacity</u>				
<input type="radio"/> Infiltration Trench (I-1) .....				
<input type="radio"/> Infiltration Basin (I-2) .....				
<input type="radio"/> Dry Well (I-3) .....				
<input type="radio"/> Underground Infiltration System (I-4) .....				
<input type="radio"/> Bioretention (F-5) .....				
<input type="radio"/> Dry Swale (O-1) .....				
<u>Standard SMPs</u>				
<input type="radio"/> Micropool Extended Detention (P-1) .....				
<input type="radio"/> Wet Pond (P-2) .....				
<input type="radio"/> Wet Extended Detention (P-3) .....				
<input type="radio"/> Multiple Pond System (P-4) .....				
<input type="radio"/> Pocket Pond (P-5) .....				
<input type="radio"/> Surface Sand Filter (F-1) .....				
<input type="radio"/> Underground Sand Filter (F-2) .....				
<input type="radio"/> Perimeter Sand Filter (F-3) .....				
<input type="radio"/> Organic Filter (F-4) .....				
<input type="radio"/> Shallow Wetland (W-1) .....				
<input type="radio"/> Extended Detention Wetland (W-2) .....				
<input type="radio"/> Pond/Wetland System (W-3) .....				
<input type="radio"/> Pocket Wetland (W-4) .....				
<input type="radio"/> Wet Swale (O-2) .....				



33. Identify the Standard SMPs in Table 1 and, if applicable, the Alternative SMPs in Table 2 that were used to treat the remaining total WQv(=Total WQv Required in 28 - Total RRv Provided in 30).

Also, provide in Table 1 and 2 the total impervious area that contributes runoff to each practice selected.

**Note:** Use Tables 1 and 2 to identify the SMPs used on Redevelopment projects.

33a. Indicate the Total WQv provided (i.e. WQv treated) by the SMPs identified in question #33 and Standard SMPs with RRv Capacity identified in question 29.

**WQv Provided**  
   .    **acre-feet**

**Note:** For the standard SMPs with RRv capacity, the WQv provided by each practice = the WQv calculated using the contributing drainage area to the practice - RRv provided by the practice. (See Table 3.5 in Design Manual)

34. Provide the sum of the Total RRv provided (#30) and the WQv provided (#33a).    .

35. Is the sum of the RRv provided (#30) and the WQv provided (#33a) greater than or equal to the total WQv required (#28)?  **Yes**  **No**

**If Yes, go to question 36.**

**If No, sizing criteria has not been met, so NOI can not be processed. SWPPP preparer must modify design to meet sizing criteria.**

36. Provide the total Channel Protection Storage Volume (CPv) required and provided or select waiver (36a), if applicable.

**CPv Required**    .    **acre-feet**      **CPv Provided**    .    **acre-feet**

36a. The need to provide channel protection has been waived because:

- Site discharges directly to tidal waters or a fifth order or larger stream.
- Reduction of the total CPv is achieved on site through runoff reduction techniques or infiltration systems.

37. Provide the Overbank Flood (Qp) and Extreme Flood (Qf) control criteria or select waiver (37a), if applicable.

**Total Overbank Flood Control Criteria (Qp)**

**Pre-Development**    .    **CFS**      **Post-development**    .    **CFS**

**Total Extreme Flood Control Criteria (Qf)**

**Pre-Development**    .    **CFS**      **Post-development**    .    **CFS**









## Appendix F

# MS4 Stormwater Pollution Prevention Plan (SWPPP) Acceptance Form







New York State Department of Environmental Conservation  
Division of Water  
625 Broadway, 4th Floor  
Albany, New York 12233-3505

**MS4 Stormwater Pollution Prevention Plan (SWPPP) Acceptance Form**  
for

**Construction Activities Seeking Authorization Under SPDES General Permit**

\*(NOTE: Attach Completed Form to Notice Of Intent and Submit to Address Above)

**I. Project Owner/Operator Information**

1. Owner/Operator Name:

2. Contact Person:

3. Street Address:

4. City/State/Zip:

**II. Project Site Information**

5. Project/Site Name:

6. Street Address:

7. City/State/Zip:

**III. Stormwater Pollution Prevention Plan (SWPPP) Review and Acceptance Information**

8. SWPPP Reviewed by:

9. Title/Position:

10. Date Final SWPPP Reviewed and Accepted:

**IV. Regulated MS4 Information**

11. Name of MS4:

12. MS4 SPDES Permit Identification Number: NYR20A \_\_\_\_\_

13. Contact Person:

14. Street Address:

15. City/State/Zip:

16. Telephone Number:

**MS4 SWPPP Acceptance Form - continued**

**V. Certification Statement - MS4 Official (principal executive officer or ranking elected official) or Duly Authorized Representative**

I hereby certify that the final Stormwater Pollution Prevention Plan (SWPPP) for the construction project identified in question 5 has been reviewed and meets the substantive requirements in the SPDES General Permit For Stormwater Discharges from Municipal Separate Storm Sewer Systems (MS4s).

Note: The MS4, through the acceptance of the SWPPP, assumes no responsibility for the accuracy and adequacy of the design included in the SWPPP. In addition, review and acceptance of the SWPPP by the MS4 does not relieve the owner/operator or their SWPPP preparer of responsibility or liability for errors or omissions in the plan.

Printed Name:

Title/Position:

Signature:

Date:

**VI. Additional Information**



## Appendix G

# Notice of Termination (NOT)

**(To Be Completed Upon Completion of Project)**





**New York State Department of Environmental Conservation  
Division of Water  
625 Broadway, 4th Floor  
Albany, New York 12233-3505**

\*(NOTE: Submit completed form to address above)\*

**NOTICE OF TERMINATION for Storm Water Discharges Authorized  
under the SPDES General Permit for Construction Activity**

**Please indicate your permit identification number:** NYR \_\_\_\_ \_

**I. Owner or Operator Information**

1. Owner/Operator Name:

2. Street Address:

3. City/State/Zip:

4. Contact Person:

4a. Telephone:

5. Contact Person E-Mail:

**II. Project Site Information**

5. Project/Site Name:

6. Street Address:

7. City/Zip:

8. County:

**III. Reason for Termination**

9a.  All disturbed areas have achieved final stabilization in accordance with the general permit and SWPPP.  
\*Date final stabilization completed (month/year): \_\_\_\_\_

9b.  Permit coverage has been transferred to new owner/operator. Indicate new owner/operator's permit identification number: NYR \_\_\_\_ \_  
(Note: Permit coverage can not be terminated by owner identified in I.1. above until new owner/operator obtains coverage under the general permit)

9c.  Other (Explain on Page 2)

**IV. Final Site Information:**

10a. Did this construction activity require the development of a SWPPP that includes post-construction stormwater management practices?  yes  no (If no, go to question 10f.)

10b. Have all post-construction stormwater management practices included in the final SWPPP been constructed?  yes  no (If no, explain on Page 2)

10c. Identify the entity responsible for long-term operation and maintenance of practice(s)?

**NOTICE OF TERMINATION for Storm Water Discharges Authorized under the  
SPDES General Permit for Construction Activity - continued**

10d. Has the entity responsible for long-term operation and maintenance been given a copy of the operation and maintenance plan required by the general permit?  yes  no

10e. Indicate the method used to ensure long-term operation and maintenance of the post-construction stormwater management practice(s):

- Post-construction stormwater management practice(s) and any right-of-way(s) needed to maintain practice(s) have been deeded to the municipality.
- Executed maintenance agreement is in place with the municipality that will maintain the post-construction stormwater management practice(s).
- For post-construction stormwater management practices that are privately owned, the deed of record has been modified to include a deed covenant that requires operation and maintenance of the practice(s) in accordance with the operation and maintenance plan.
- For post-construction stormwater management practices that are owned by a public or private institution (e.g. school, college, university), or government agency or authority, policy and procedures are in place that ensures operation and maintenance of the practice(s) in accordance with the operation and maintenance plan.

10f. Provide the total area of impervious surface (i.e. roof, pavement, concrete, gravel, etc.) constructed within the disturbance area? \_\_\_\_\_ (acres)

11. Is this project subject to the requirements of a regulated, traditional land use control MS4?  yes  no  
(If Yes, complete section VI - "MS4 Acceptance" statement)

**V. Additional Information/Explanation:**

(Use this section to answer questions 9c. and 10b., if applicable)

**VI. MS4 Acceptance - MS4 Official (principal executive officer or ranking elected official) or Duly Authorized Representative** (Note: Not required when 9b. is checked -transfer of coverage)

I have determined that it is acceptable for the owner or operator of the construction project identified in question 5 to submit the Notice of Termination at this time.

Printed Name:

Title/Position:

Signature:

Date:

**NOTICE OF TERMINATION for Storm Water Discharges Authorized under the  
SPDES General Permit for Construction Activity - continued**

**VII. Qualified Inspector Certification - Final Stabilization:**

I hereby certify that all disturbed areas have achieved final stabilization as defined in the current version of the general permit, and that all temporary, structural erosion and sediment control measures have been removed. Furthermore, I understand that certifying false, incorrect or inaccurate information is a violation of the referenced permit and the laws of the State of New York and could subject me to criminal, civil and/or administrative proceedings.

Printed Name:

Title/Position:

Signature:

Date:

**VIII. Qualified Inspector Certification - Post-construction Stormwater Management Practice(s):**

I hereby certify that all post-construction stormwater management practices have been constructed in conformance with the SWPPP. Furthermore, I understand that certifying false, incorrect or inaccurate information is a violation of the referenced permit and the laws of the State of New York and could subject me to criminal, civil and/or administrative proceedings.

Printed Name:

Title/Position:

Signature:

Date:

**IX. Owner or Operator Certification**

I hereby certify that this document was prepared by me or under my direction or supervision. My determination, based upon my inquiry of the person(s) who managed the construction activity, or those persons directly responsible for gathering the information, is that the information provided in this document is true, accurate and complete. Furthermore, I understand that certifying false, incorrect or inaccurate information is a violation of the referenced permit and the laws of the State of New York and could subject me to criminal, civil and/or administrative proceedings.

Printed Name:

Title/Position:

Signature:

Date:

(NYS DEC Notice of Termination - January 2010)



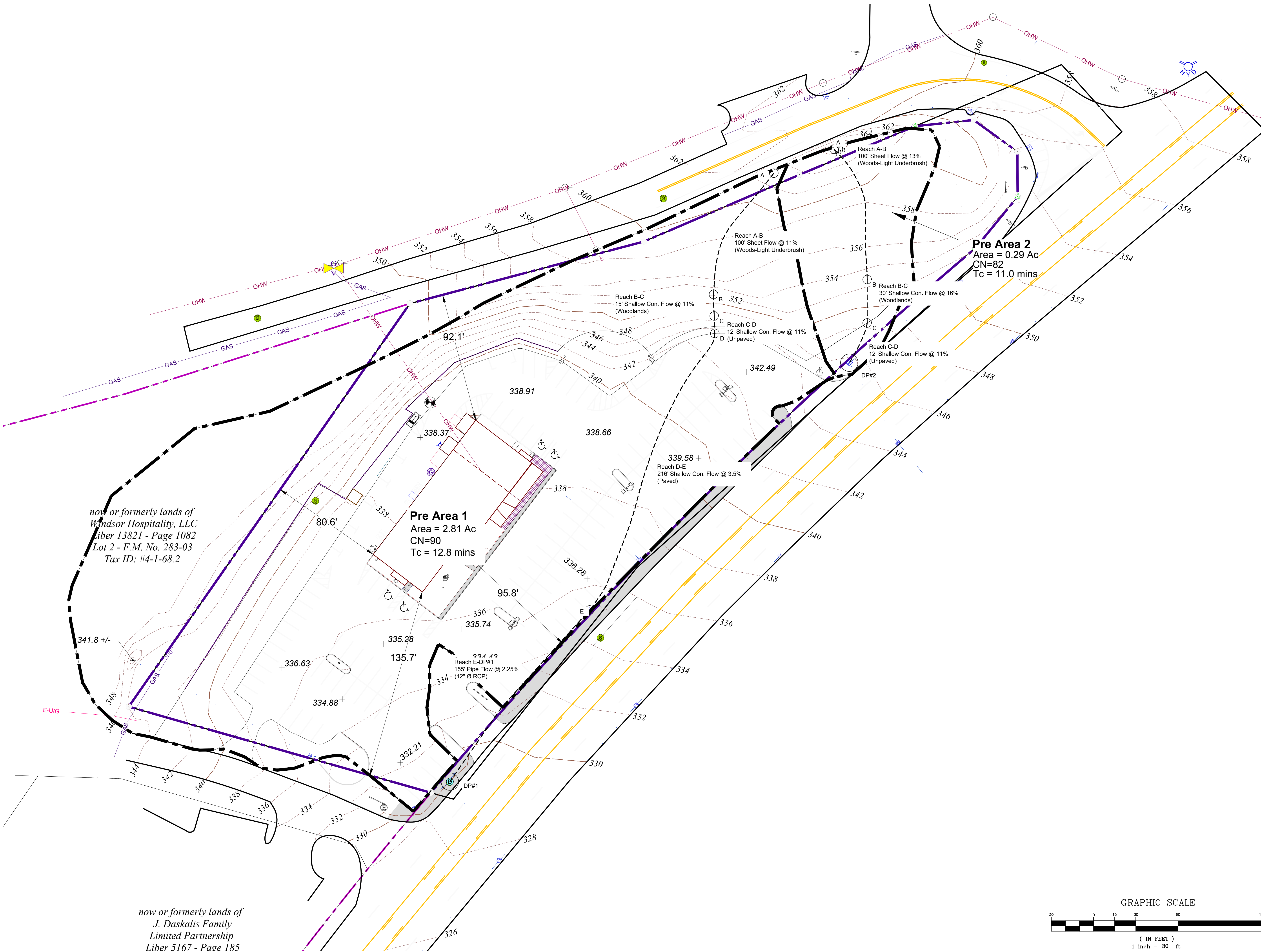




## Appendix H

# Pre & Post Hydrology





now or formerly lands of Windsor Hospitality, LLC  
Liber 13821 - Page 1082  
Lot 2 - F.M. No. 283-03  
Tax ID: #4-1-68.2

now or formerly lands of J. Daskalis Family  
Limited Partnership  
Liber 5167 - Page 185

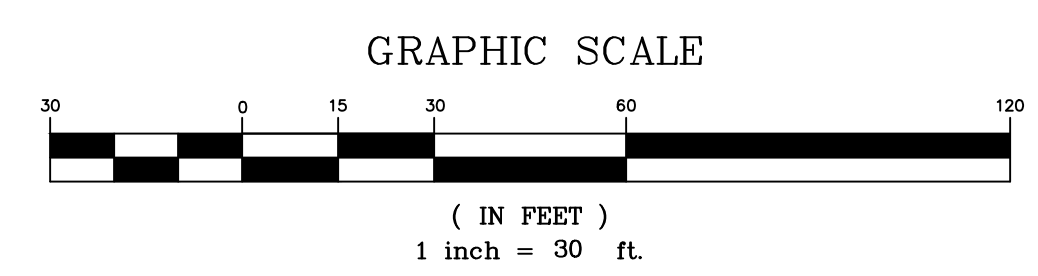
Town of New Windsor  
Planning Board Approval  
NWPB Project No. 17-04  
Tax Map Parcel No. 4-1-12.11 (2.81 Ac)

IT IS A VIOLATION OF NEW YORK STATE EDUCATION LAW FOR ANY PERSONS TO ALTER THESE PLANS, SPECIFICATIONS, OR REPORTS IN ANY WAY, UNLESS ACTING UNDER THE DIRECTION OF A LICENSED PROFESSIONAL ENGINEER OR LAND SURVEYOR.

Mark A. Day, PE	
2016:003	License No. 069646

**M.A. DAY Engineering, PC**  
Consulting Engineers  
3 Van Wyck Lane Suite 2  
Wappingers Falls, New York  
(845)-223-3202

PROJECT: 935 Union Ave  
Town of New Windsor Orange County, NY  
DRAWING: Pre-Development Hydrology  
SCALE: 1" = 30'  
DATE: 04-17-18  
DRAWN BY: DJL  
CHECKED BY: DJL  
DRAWING NO.: DA101  
1 of 2





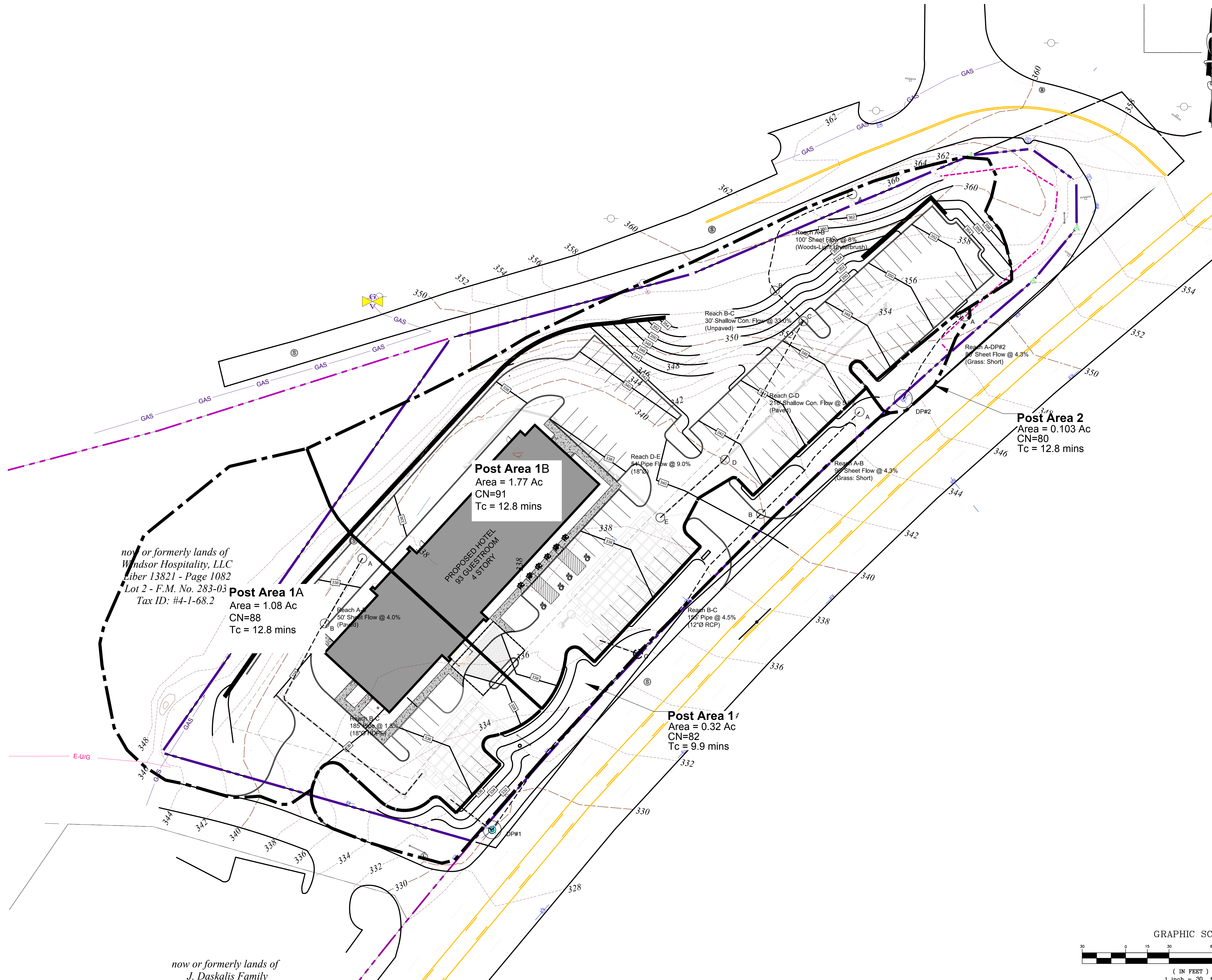


**LEGEND**

- EXISTING PROPERTY LINE
- EXISTING 10 FT CONTOUR LINE
- EXISTING 2 FT CONTOUR LINE
- EXISTING TREE LINE
- EXISTING TREES
- EXISTING SIGN
- EXISTING CATCH BASIN
- EXISTING SANITARY MANHOLE
- EXISTING WATER VALVE
- EXISTING UTILITY POLE
- EXISTING FENCELINE
- EXISTING OVERHEAD WIRE
- EXISTING SANITARY SEWER LINE
- EXISTING WATER MAIN
- PROPOSED CONTOUR LINE
- PROPOSED CONCRETE CURB
- PROPOSED CONCRETE SIDEWALK
- PROPOSED SIGN
- PROPOSED RETAINING WALL

**SITE NOTES**

1. PROPERTY BOUNDARY, TOPOGRAPHY AND EXISTING UTILITY SHOWN HEREON ARE BASED ON A SURVEY ENTITLED "BOUNDARY & TOPOGRAPHIC SURVEY OF THE LANDS OF BANTA REALTY" PREPARED BY JONATHAN N MILLEN, L.L.S., DATED MARCH 24, 2017.



now or formerly lands of Windsor Hospitality, LLC  
 Liber 13821 - Page 1082  
 Lot 2 - F.M. No. 283-03  
 Tax ID: #4-1-68.2

**Post Area 1A**  
 Area = 1.08 Ac  
 CN=88  
 Tc = 12.8 mins

**Post Area 1B**  
 Area = 1.77 Ac  
 CN=91  
 Tc = 12.8 mins

**Post Area 1'**  
 Area = 0.32 Ac  
 CN=82  
 Tc = 9.9 mins

**Post Area 2**  
 Area = 0.103 Ac  
 CN=80  
 Tc = 12.8 mins

PROPOSED HOTEL  
 93 GUESTROOM  
 4 STORY

**Town of New Windsor Planning Board Approval**

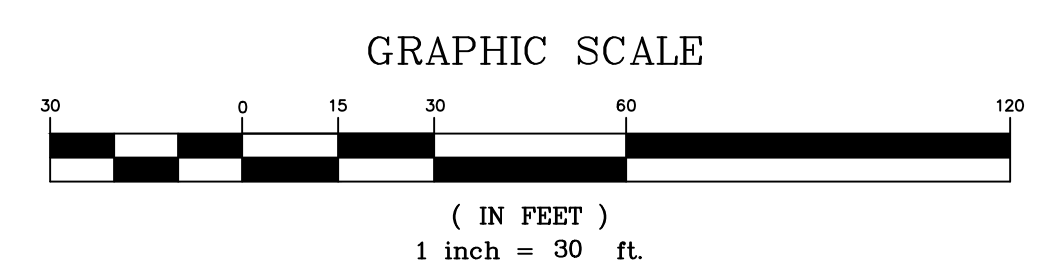
NWPB Project No. 17-04  
  
 Tax Map Parcel No. 4-1-12.11 (2.81 Ac)

IT IS A VIOLATION OF NEW YORK STATE EDUCATION LAW FOR ANY PERSONS TO ALTER THESE PLANS, SPECIFICATIONS, OR REPORTS IN ANY WAY, UNLESS ACTING UNDER THE DIRECTION OF A LICENSED PROFESSIONAL ENGINEER OR LAND SURVEYOR.

Mark A. Day, PE	
Project No.	2016.003
License No.	069646

**M.A. DAY Engineering, PC**  
 Consulting Engineers  
 3 Van Wyck Lane Suite 2  
 Wappingers Falls, New York  
 (845)-223-3202

<b>935 Union Ave</b>	
Town of New Windsor	Orange County, NY
<b>Post-Development Hydrology</b>	
SCALE 1" = 30'	DRAWN BY D.J.L.
DATE 04-17-18	CHECKED BY D.J.L.
<b>DA201</b>	
2 of 2	



now or formerly lands of J. Daskalis Family







## Appendix I

# SWPPP Plan & Details



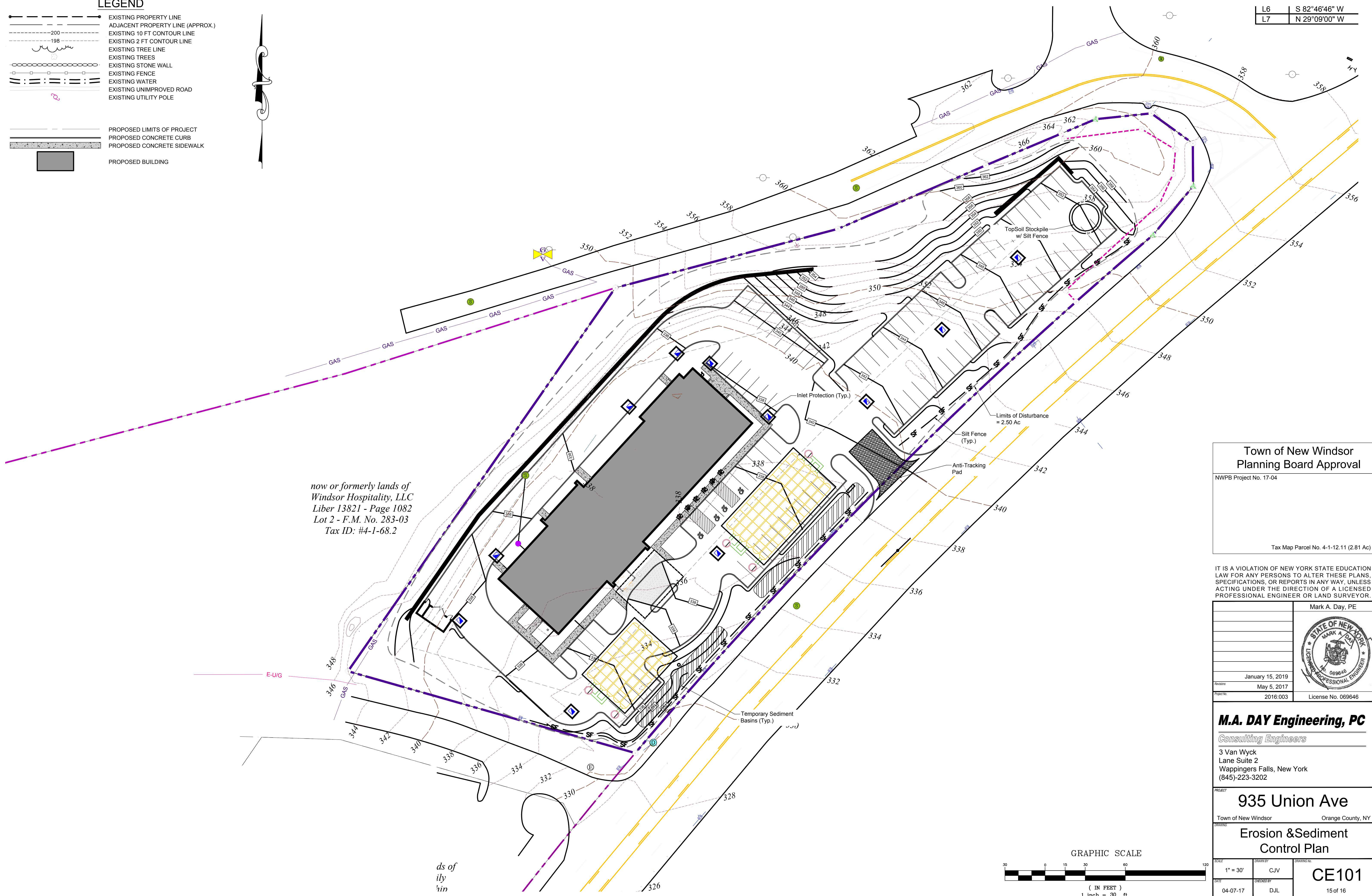


L6 S 82°46'46" W  
L7 N 29°09'00" W

**LEGEND**


- EXISTING PROPERTY LINE
- - - ADJACENT PROPERTY LINE (APPROX.)
- - - 100 EXISTING 10 FT CONTOUR LINE
- - - 200 EXISTING 2 FT CONTOUR LINE
- - - 198 EXISTING TREE LINE
- EXISTING TREES
- EXISTING STONE WALL
- - - EXISTING FENCE
- - - EXISTING WATER
- - - EXISTING UNIMPROVED ROAD
- EXISTING UTILITY POLE
  
- PROPOSED LIMITS OF PROJECT
- PROPOSED CONCRETE CURB
- PROPOSED CONCRETE SIDEWALK
  
- PROPOSED BUILDING

now or formerly lands of  
Windsor Hospitality, LLC  
Liber 13821 - Page 1082  
Lot 2 - F.M. No. 283-03  
Tax ID: #4-1-68.2



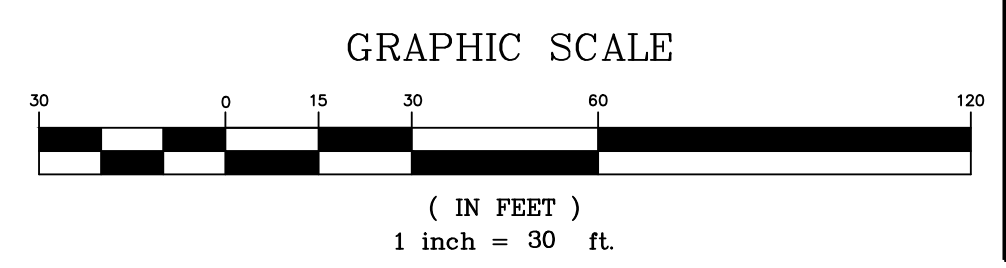
**Town of New Windsor  
Planning Board Approval**  
NWPB Project No. 17-04  
  
Tax Map Parcel No. 4-1-12.11 (2.81 Ac)

IT IS A VIOLATION OF NEW YORK STATE EDUCATION LAW FOR ANY PERSONS TO ALTER THESE PLANS, SPECIFICATIONS, OR REPORTS IN ANY WAY, UNLESS ACTING UNDER THE DIRECTION OF A LICENSED PROFESSIONAL ENGINEER OR LAND SURVEYOR.

Mark A. Day, PE	
	
Date:	January 15, 2019
Revision:	May 5, 2017
Project No.:	2016.003
License No.:	069646

**M.A. DAY Engineering, PC**  
Consulting Engineers  
3 Van Wyck Lane Suite 2  
Wappingers Falls, New York  
(845)-223-3202

<b>935 Union Ave</b>	
Town of New Windsor Orange County, NY	
<b>Erosion &amp; Sediment Control Plan</b>	
SCALE	1" = 30'
DATE	04-07-17
DESIGNED BY	CJV
CHECKED BY	DJL
<b>CE101</b>	
15 of 16	









**SPDES GENERAL PERMIT GP-0-15-002 COMPLIANCE NOTES:**  
THE CONTRACTOR SHALL BE RESPONSIBLE FOR COMPLYING WITH THE FOLLOWING:

- THE CONTRACTOR AND HIS/HER SUBCONTRACTORS SHALL READ AND UNDERSTAND THE CONDITIONS OF THE "NYSDEC SPDES GENERAL PERMIT FOR STORM WATER DISCHARGES FROM CONSTRUCTION ACTIVITIES", GP-0-15-002 FOR THIS PROJECT.
- THE CONTRACTOR AND HIS/HER SUBCONTRACTORS SHALL SIGN A COPY OF THE GENERAL PERMIT, GP-0-15-002, CERTIFICATION STATEMENT AS IDENTIFIED IN THE APPENDICES OF THE STORMWATER POLLUTION PREVENTION PLAN (SWPPP).
- THE CONTRACTOR SHALL OBTAIN ALL REQUIRED PERMITS NECESSARY FOR THE WORK OUTLINED HEREIN.
- THE CONTRACTOR SHALL BE RESPONSIBLE FOR IMPLEMENTATION OF ALL STORMWATER POLLUTION PREVENTION MEASURES OUTLINED IN THE SWPPP AND PROJECT PLANS.
- THE CONTRACTOR SHALL HOLD A PRECONSTRUCTION CONFERENCE WITH THE OWNER'S REPRESENTATIVES AT LEAST ONE WEEK PRIOR TO COMMENCEMENT OF CONSTRUCTION.
- THE CONTRACTOR/OWNER SHALL HAVE A QUALIFIED PROFESSIONAL, AS DEFINED WITHIN THE NYSDEC SPDES GENERAL PERMIT GP-0-15-002, CONDUCT AN INITIAL SITE ASSESSMENT PRIOR TO CONSTRUCTION FOLLOWING THE COMMENCEMENT OF CONSTRUCTION AT LEAST EVERY 7 CALENDAR DAYS. REFER TO SWPPP FOR INSPECTION GUIDELINES.
- PRIOR TO COMMENCEMENT OF CONSTRUCTION, A QUALIFIED PROFESSIONAL (HIRED BY CONTRACTOR OR OWNER) SHALL CONDUCT AN ASSESSMENT OF THE SITE AND CERTIFY THAT THE APPROPRIATE EROSION AND SEDIMENT CONTROL STRUCTURES AS DEPICTED ON THE PLANS HAVE BEEN ADEQUATELY INSTALLED AND IMPLEMENTED. CONTRACTOR SHALL CONTACT THE PROJECT ENGINEER ONCE THE EROSION AND SEDIMENT CONTROL STRUCTURES HAVE BEEN INSTALLED. REFER TO SWPPP FOR INSPECTION GUIDELINES.
- THE OWNER/OPERATOR SHALL MAINTAIN A RECORD OF ALL EROSION AND SEDIMENT CONTROL INSPECTION REPORTS AT THE SITE IN A LOG BOOK. THE SITE LOG BOOK SHALL BE MAINTAINED ON-SITE AND BE MADE AVAILABLE TO THE PERMITTING AUTHORITY. THE OWNER/CONTRACTOR SHALL POST AT THE SITE, IN A PUBLICLY ACCESSIBLE LOCATION, A SUMMARY OF THE SITE INSPECTION ACTIVITIES ON A MONTHLY BASIS.
- THE OWNER/OPERATOR SHALL FILE A NOTICE OF INTENT (NOI) WITH THE NYSDEC AND LOCAL GOVERNING AUTHORITY PRIOR TO COMMENCING CONSTRUCTION ACTIVITIES AND A NOTICE OF TERMINATION (NOT) WITH NYSDEC FOLLOWING CONSTRUCTION ACTIVITIES.

**1 SPDES GENERAL PERMIT COMPLIANCE NOTES**  
NOT TO SCALE

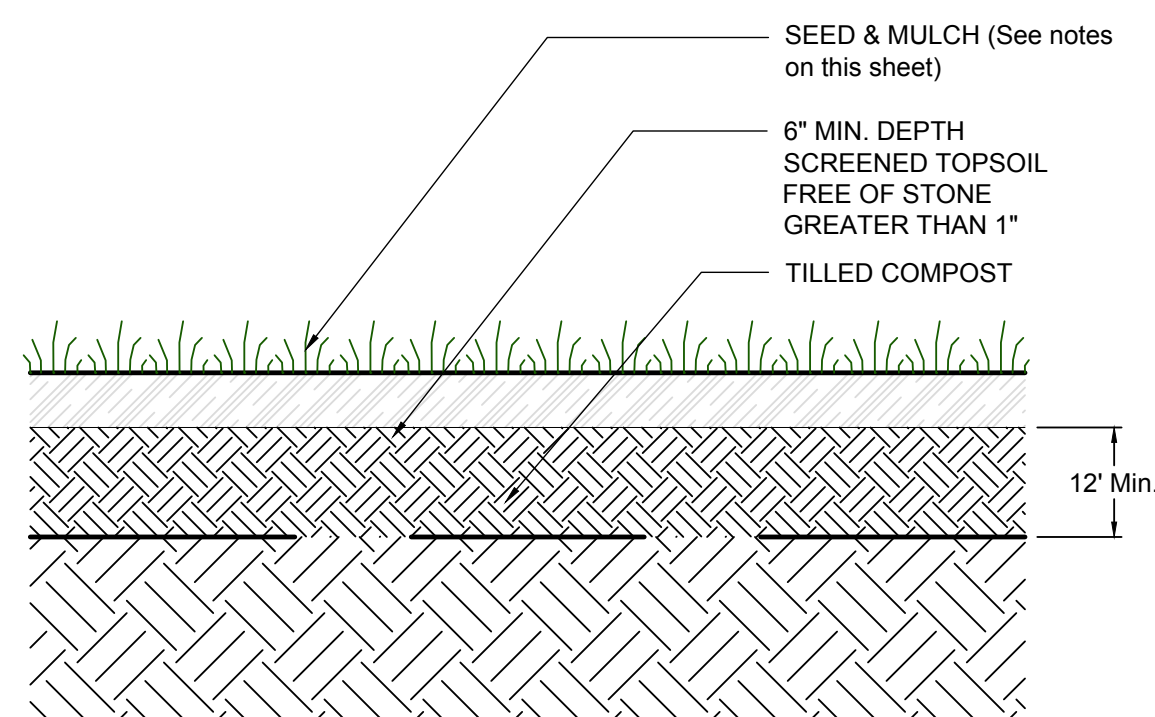
**EROSION AND SEDIMENT CONTROL MEASURES:**

- ALL EROSION AND SEDIMENT CONTROL MEASURES ARE TO BE IN STRICT COMPLIANCE WITH "NEW YORK STATE STANDARDS AND SPECIFICATIONS FOR EROSION AND SEDIMENT CONTROL", AUGUST 2005.
- DAMAGE TO SURFACE WATERS RESULTING FROM EROSION AND SEDIMENTATION SHALL BE MINIMIZED BY STABILIZING DISTURBED AREAS AND BY REMOVING SEDIMENT FROM CONSTRUCTION SITE DISCHARGES.
- AS MUCH AS IS PRACTICAL, EXISTING VEGETATION SHALL BE PRESERVED. FOLLOWING THE COMPLETION OF CONSTRUCTION ACTIVITIES IN ANY PORTION OF THE SITE, PERMANENT VEGETATION SHALL BE ESTABLISHED ON ALL EXPOSED SOILS.
- SITE PREPARATION ACTIVITIES SHALL BE PLANNED TO MINIMIZE THE SCOPE AND DURATION OF SOIL DISRUPTION.
- PERMANENT TRAFFIC CORRIDORS SHALL BE ESTABLISHED AND "ROUTES OF CONVENIENCE" SHALL BE AVOIDED. STABILIZED CONSTRUCTION ENTRANCES SHALL BE INSTALLED AT ALL POINTS OF ENTRY ONTO THE PROJECT SITE.
- SEEDED AREAS TO BE MULCHED WITH STRAW OR HAY MULCH IN ACCORDANCE WITH VEGETATIVE COVER SPECIFICATIONS.
- THE CONTRACTOR IS RESPONSIBLE FOR THE INSTALLATION AND MAINTENANCE OF ALL EROSION AND SEDIMENT CONTROL MEASURES THROUGHOUT THE COURSE OF CONSTRUCTION.
- THE CONTRACTOR IS RESPONSIBLE FOR CONTROLLING DUST BY SPRINKLING EXPOSED SOIL AREAS PERIODICALLY WITH WATER AS REQUIRED. THE CONTRACTOR IS TO SUPPLY ALL EQUIPMENT AND WATER.
- WHEN ALL DISTURBED AREAS ARE STABLE, ALL TEMPORARY EROSION AND SEDIMENT CONTROL MEASURES SHALL BE REMOVED.

**MAINTENANCE OF EROSION AND SEDIMENT CONTROL MEASURES:**

- PERMANENT AND TEMPORARY VEGETATION:**  
INSPECT ALL AREAS THAT HAVE RECEIVED VEGETATION EVERY SEVEN DAYS. ALL AREAS DAMAGED BY EROSION OR WHERE SEED HAS NOT ESTABLISHED SHALL BE REPAIRED AND RESEED IMMEDIATELY.
- STABILIZED CONSTRUCTION ENTRANCE:**  
INSPECT THE ENTRANCE PAD EVERY SEVEN DAYS. CHECK FOR MUD, SEDIMENT BUILD-UP AND PAD INTEGRITY. MAKE DAILY INSPECTIONS DURING WET WEATHER. RESHAPE PAD AS NEEDED FOR DRAINAGE AND RUNOFF CONTROL. WASH AND REPLACE STONE AS NEEDED. THE STONE IN THE ENTRANCE SHOULD BE WASHED OR REPLACED WHENEVER THE ENTRANCE FAILS TO REDUCE MUD BEING CARRIED OFF-SITE BY VEHICLES. IMMEDIATELY REMOVE MUD AND SEDIMENT TRACKED OR WASHED ONTO PUBLIC ROADS BY BRUSHING OR SWEEPING. REMOVE TEMPORARY CONSTRUCTION ENTRANCE AS SOON AS THEY ARE NO LONGER NEEDED TO PROVIDE ACCESS TO THE SITE.
- SILT FENCE:**  
INSPECT FOR DAMAGE EVERY SEVEN DAYS. MAKE ALL REPAIRS IMMEDIATELY. REMOVE SEDIMENT FROM THE UP-SLOPE FACE OF THE FENCE BEFORE IT ACCUMULATES TO A HEIGHT EQUAL TO 1/3 THE HEIGHT OF THE FENCE. IF FENCE FABRIC TEARS, BEGINS TO DECOMPOSE, OR IN ANY WAY BECOMES INEFFECTIVE, REPLACE THE AFFECTED SECTION OF FENCE IMMEDIATELY.
- SOIL STOCKPILE:**  
INSPECT SEDIMENT CONTROL BARRIERS (SILT FENCE OR HAY BALE) AND VEGETATION FOR DAMAGE EVERY SEVEN DAYS. MAKE ALL REPAIRS IMMEDIATELY. REMOVE SEDIMENT FROM THE UP-SLOPE FACE OF THE SEDIMENT CONTROL BARRIER BEFORE IT ACCUMULATES TO A HEIGHT EQUAL TO 1/3 THE HEIGHT OF THE SEDIMENT CONTROL BARRIER. IF SEDIMENT CONTROL BARRIER TEARS, BEGINS TO DECOMPOSE, OR IN ANYWAY BECOMES INEFFECTIVE, REPLACE THE AFFECTED SECTION OF SEDIMENT CONTROL BARRIER IMMEDIATELY. REVEGETATE DISTURBED AREA TO STABILIZE SOIL STOCK PILE. REMOVE THE SEDIMENT CONTROL BARRIER WHEN THE SOIL STOCKPILE HAS BEEN REMOVED.
- INLET PROTECTION:**  
INSPECT INLET PROTECTION FOR DAMAGE EVERY SEVEN DAYS. MAKE ALL REPAIRS IMMEDIATELY. REMOVE SEDIMENT AS NECESSARY TO PROVIDE FOR ADEQUATE STORAGE VOLUME FOR SUBSEQUENT RAINS.
- DUST CONTROL:**  
SCHEDULE CONSTRUCTION OPERATIONS TO MINIMIZE THE AMOUNT OF DISTURBED AREAS AT ANY ONE TIME DURING THE COURSE OF WORK. APPLY TEMPORARY SOIL STABILIZATION PRACTICES SUCH AS MULCHING, SEEDING, AND SPRAYING (WATER). STRUCTURAL MEASURES (MULCH, SEEDING) SHALL BE INSTALLED IN DISTURBED AREAS BEFORE SIGNIFICANT BLOWING PROBLEMS DEVELOP. WATER SHALL BE SPRAYED AS NEEDED, REPEAT AS NEEDED, BUT AVOID EXCESSIVE SPRAYING, WHICH COULD CREATE RUNOFF AND EROSION PROBLEMS.

**5 EROSION & SEDIMENT CONTROL NOTES**  
NOT TO SCALE



**9 SOIL RESTORATION DETAIL**  
NOT TO SCALE

- DURING PERIODS OF RELATIVELY LOW MODERATE SUBSOIL MOISTURE, THE DISTURBED SUBSOILS ARE RETURNED TO ROUGH GRADE AND THE FOLLOWING SOIL RESTORATION STEPS APPLIED:
- APPLY 3 INCHES OF COMPOST OVER SUBSOIL
  - TILL COMPOST INTO SUBSOIL TO A DEPTH OF AT LEAST 12 INCHES USING A CAT-MOUNTED RIPPER, TRACTOR-MOUNTED DISC, OR TILLER, MIXING, AND CIRCULATING AIR AND COMPOST INTO SUBSOILS.
  - ROCK-PICK UNTIL UPLIFTED STONE/ROCK MATERIALS OF FOUR INCHES AND LARGER SIZE ARE CLEANED OF THE SITE.
  - APPLY TOPSOIL TO A DEPTH OF 6 INCHES.
  - VEGETATE AS REQUIRED BY APPROVED PLANS.

**Construction Waste Management Plan**

Construction waste management practices are designed to maintain a clean and orderly work environment. This will reduce the potential for significant materials to come into contact with stormwater. A maintenance schedule shall be developed for these areas. The general contractor shall implement the following practices:

- Material resulting from the clearing and grubbing operation will be stockpiled up slope from adequate sedimentation controls.
- Equipment cleaning, maintenance, and repair areas shall be designated and protected by a temporary perimeter berm.
- The use of detergents for large scale washing is prohibited (i.e., vehicles, buildings, pavement surfaces, etc.).
- Spill Prevention and Response**  
A Spill Prevention and Response Plan shall be developed for the site by the general contractor. The plan shall detail the steps needed to be followed in the event of an accidental spill and shall identify contact names and phone numbers of people and agencies that must be notified.  
The plan shall include Material Safety Data Sheets (MSDS) for all materials to be stored on-site. All workers on-site will be required to be trained on safe handling and spill prevention procedures for all materials used during construction. Regular tailgate safety meetings shall be held and all workers that are expected on the site during the work shall be required to attend.
- Material Storage**  
Construction materials shall be stored in a dedicated staging area. The staging area shall be located in an area that minimizes the impacts of the construction materials effecting stormwater quality.  
Chemicals, paints, solvents, fertilizers, and other toxic material must be stored in waterproof containers. Except during application, the contents must be kept in trucks or within storage facilities. Runoff containing such material must be collected, removed from the site, treated and disposed at an approved solid waste or chemical disposal facility.
- Temporary Concrete Washout Facility**  
Temporary concrete washout facilities should be located a minimum of 50 ft from storm drain inlets, open drainage facilities, and watercourses. Each facility should be located away from construction traffic or access areas to prevent disturbance or tracking. A sign should be installed adjacent to each washout facility to inform concrete equipment operators to utilize the proper facilities.  
When temporary concrete washout facilities are no longer required for the work, the hardened concrete shall be removed and disposed of. Materials used to construct the temporary concrete washout facilities shall be removed from the site and disposed of. Holes, depressions or other ground disturbance caused by the removal of the temporary concrete washout facilities shall be backfilled and/or repaired and seeded or mulched for final stabilization.
- Solid Waste Disposal**  
No solid materials, including building materials, are allowed to be discharged from the site with stormwater. All solid waste, including disposable materials incidental to the major construction activities, must be collected and placed in containers. The containers will be emptied periodically by a contract trash disposal service and hauled away from the site.  
Substances that have the potential for polluting surface and/or groundwater must be controlled by whatever means necessary in order to ensure that they do not discharge from the site. As an example, special care must be exercised during equipment fueling and servicing operations. If a spill occurs, it must be contained and disposed so that it will not flow from the site or enter groundwater, even if this requires removal, treatment, and disposal of soil. In this regard, potentially polluting substances should be handled in a manner consistent with the impact they represent.
- Water Source**  
Non-stormwater components of site discharge must be clean water. Water used for construction, which discharges from the site, must originate from a public water supply or private well approved by the Health Department. Water used for construction that does not originate from an approved public supply must not discharge from the site. It can be retained in the ponds until it infiltrates and evaporates.

**2 CONSTRUCTION WASTE MANAGEMENT PLAN**  
NOT TO SCALE

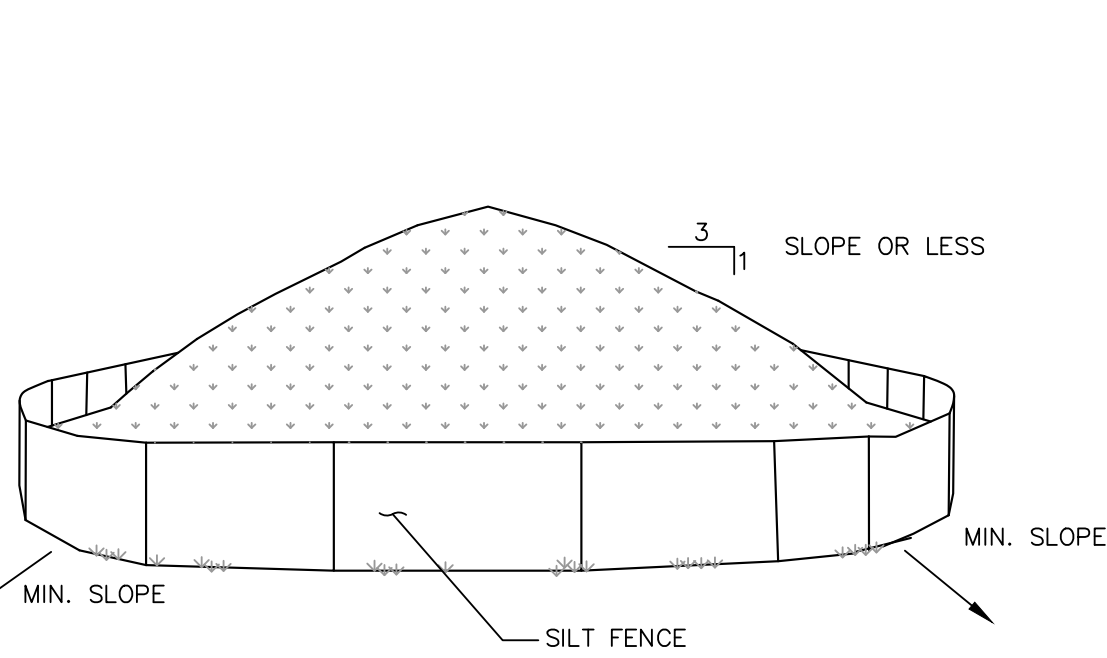
**PRE-CONSTRUCTION SEQUENCE:**

- Non-disturbance areas shall be marked with 4-ft orange snow fencing to Town Engineer's satisfaction prior to site disturbance, and shall be maintained until issuance of a c.o.
- Hold a pre-construction meeting with the owner/operator, site engineer, Town Engineer, trained contractor, qualified erosion control inspector and building inspector. Place a copy of the SWPPP report on site along with a copy of the inspector's log book containing copies of the weekly inspections. (applicant's erosion & sediment control inspection agent shall conduct an inspection on a weekly basis)

**CONSTRUCTION SEQUENCE:**

- Install and stabilize temporary erosion & sediment control measures as shown on the Erosion & Sediment Control plan.
- Install temporary diversion swales as necessary to divert runoff away from construction.
- Commence initial demolition of existing building.
- Begin remaining site grading, driveway grade construction and foundation excavation.
- Rough out driveway and parking area to sub-grade.
- Pour concrete footings and foundations for proposed buildings.
- Install remaining site utilities and/or infrastructure.
- Pave driveway and install curbing once all major work on site is complete, as required.
- Previous pavement practices should be installed toward the end of the construction period. Upstream construction shall be completed and stabilized before connection to porous pavement system. A dense and vigorous vegetative cover shall be established over any contributing pervious drainage areas before runoff can be accepted into the facility.
- Install on-pavement temporary inlet protection.
- Topsoil, seed and mulch all disturbed areas that have obtained finished grade elevations as per the soil restoration detail.
- Seed and mulch all disturbed areas that will not be re-disturbed for at least 14 days.
- Finalize building construction.
- Pave parking area and drives with final top-coat of asphalt.
- Once all major site disturbance activities have ceased and the site has achieved final stabilization, file an N.O.T. (notice of termination) with NYSDEC.
- Terminate erosion control inspections.

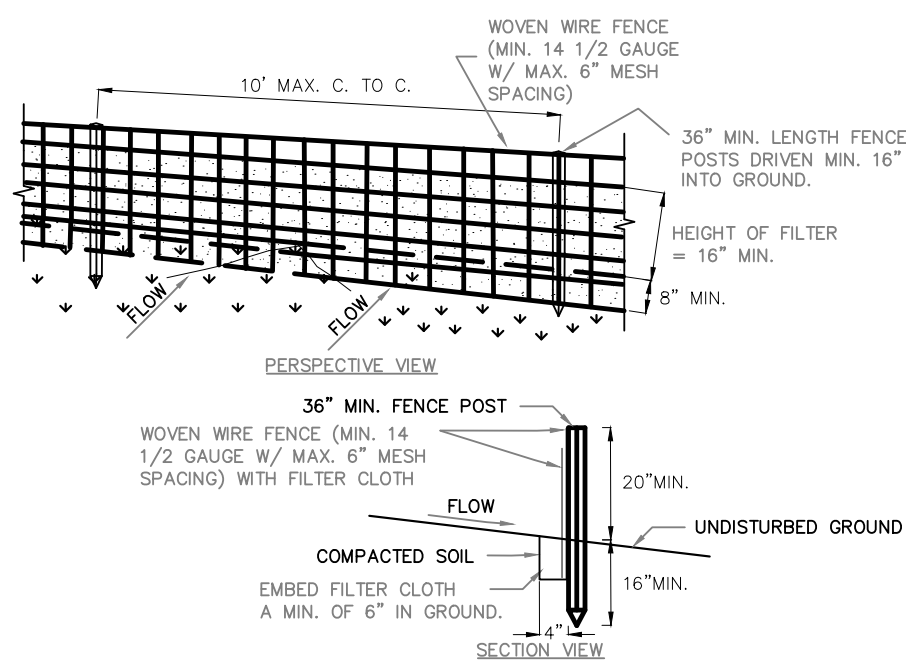
**6 CONSTRUCTION SEQUENCE**  
NOT TO SCALE



- NOTES:**
- AREA CHOSEN FOR STOCKPILING OPERATIONS SHALL BE DRY AND STABLE.
  - MAXIMUM SLOPE OF STOCKPILE SHALL BE 1V:2H.
  - UPON COMPLETION OF SOIL STOCKPILING, EACH PILE SHALL BE SURROUNDED WITH SILT FENCING, THEN STABILIZED WITH VEGETATION OR COVERED.
  - SEE SPECIFICATIONS FOR INSTALLATION OF SILT FENCE.
  - HAYBALES TO BE USED WHERE STOCKPILES ARE LOCATED ON PAVED AREAS.

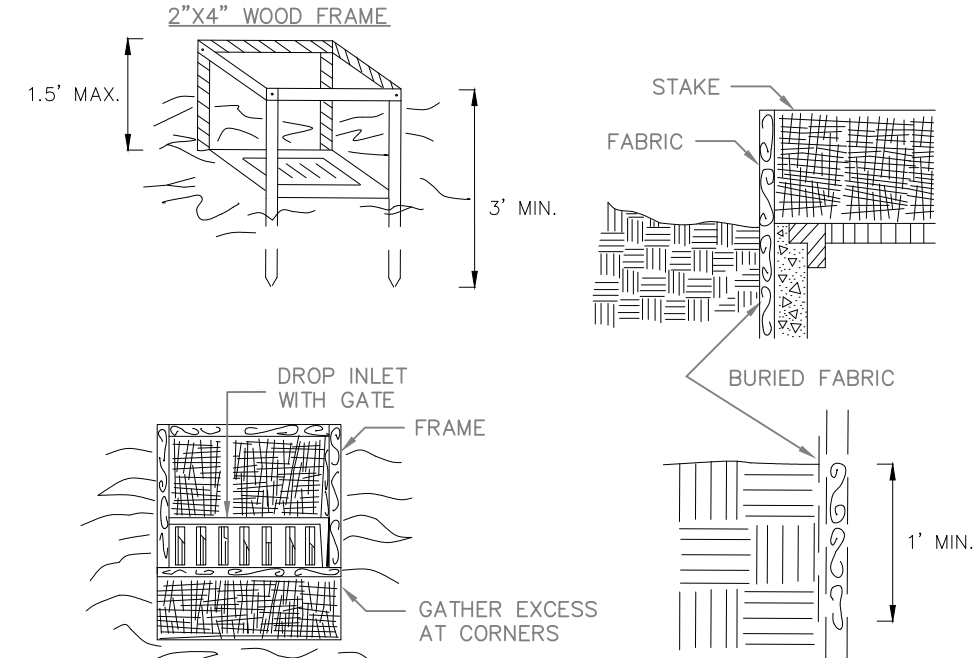
**10 TEMPORARY SOIL STOCKPILE DETAIL**  
NOT TO SCALE

**3 SILT FENCE DETAIL**  
NOT TO SCALE



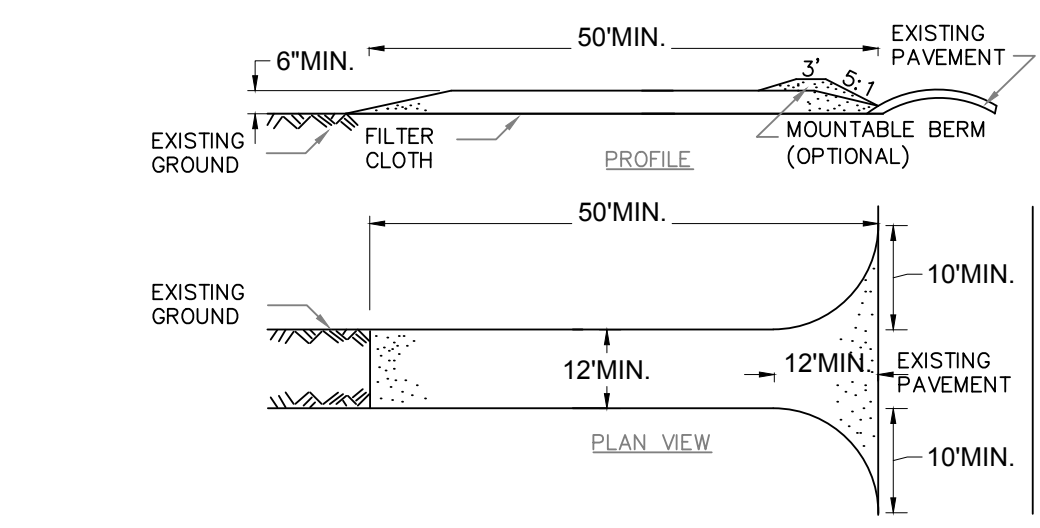
KENTUCKY BLUEGRASS	40%
CREeping RED FESCUE	40%
RYE GRASS	20%

**7 SEEDING & MULCHING NOTES**  
NOT TO SCALE



- CONSTRUCTION SPECIFICATIONS**
- FILTER FABRIC SHALL HAVE AN EOS OF 40-85. BURLAP MAY BE USED FOR SHORT TERM APPLICATIONS.
  - CUT FABRIC FROM A CONTINUOUS ROLL TO ELIMINATE JOINTS. IF JOINTS ARE NEEDED THEY WILL BE OVERLAPPED TO THE NEXT STAKE.
  - STAKE MATERIALS WILL BE STANDARD 2" x 4" WOOD OR EQUIVALENT. METAL WITH A MINIMUM LENGTH OF 3 FEET.
  - SPACE STAKES EVENLY AROUND INLET 3 FEET APART AND DRIVE A MINIMUM 18 INCHES DEEP. SPACES GREATER THAN 3 FEET MUST BE BRIDGED WITH THE USE OF WIRE MESH BEHIND THE FILTER FABRIC FOR SUPPORT.
  - FABRIC SHALL BE EMBEDDED 1 FOOT MINIMUM BELOW GROUND AND BACKFILLED. IT SHALL BE SECURELY FASTENED TO THE STAKES AND FRAME.
  - 2" x 4" WOOD FRAME SHALL BE COMPLETED AROUND THE CREST OF THE FABRIC FOR OVER FLOW STABILITY. MAXIMUM DRAINAGE AREA 1 ACRE

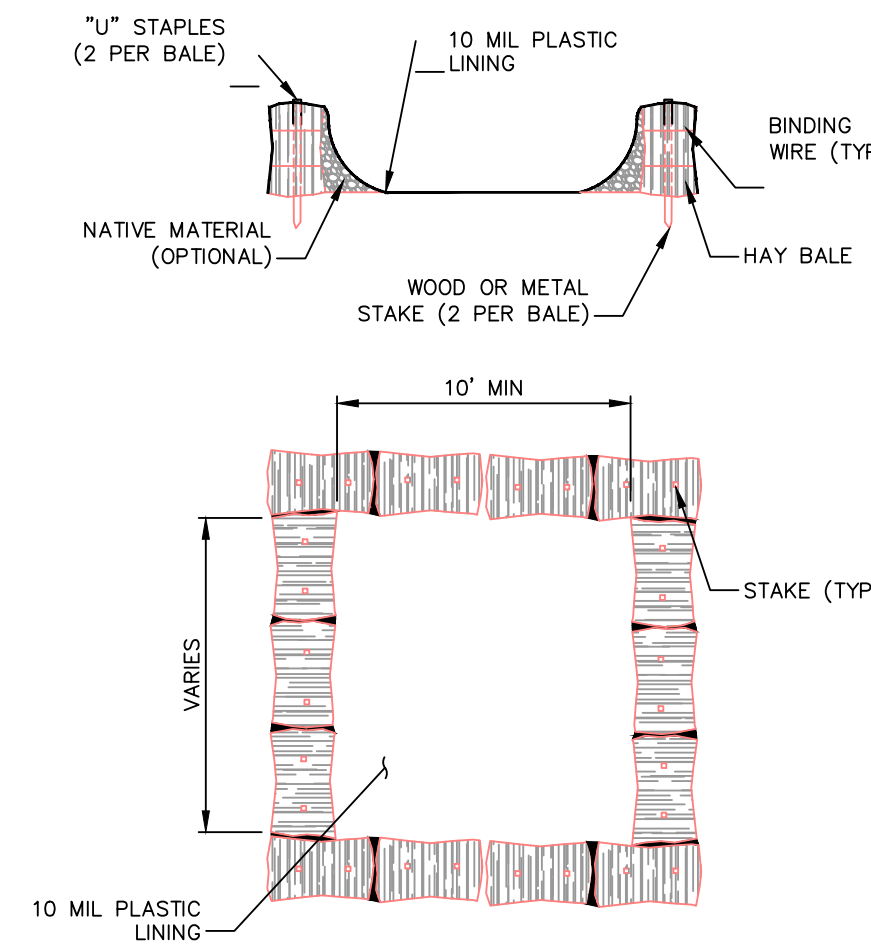
**11 FILTER FABRIC DROP INLET PROTECTION**  
NOT TO SCALE



**CONSTRUCTION SPECIFICATIONS**

- STONE SIZE - USE 1-4 INCH STONE, OR RECLAIMED OR RECYCLED CONCRETE EQUIVALENT.
- LENGTH - NOT LESS THAN 50 FEET (EXCEPT ON A SINGLE RESIDENCE LOT WHERE A 30 FOOT MINIMUM LENGTH WOULD APPLY).
- THICKNESS - NOT LESS THAN SIX (6) INCHES.
- WIDTH - TWELVE (12) FOOT MINIMUM, BUT NOT LESS THAN THE FULL WIDTH AT POINTS WHERE INGRESS OR EGRESS OCCURS. TWENTY-FOUR (24) FOOT IF SINGLE ENTRANCE TO SITE.
- GEOTEXTILE - WILL BE PLACED OVER THE ENTIRE AREA PRIOR TO PLACING OF STONE.
- SURFACE WATER - ALL SURFACE WATER FLOWING OR DIVERTED TOWARD CONSTRUCTION ACCESS SHALL BE PIPED BENEATH THE ENTRANCE. IF PIPING IS IMPRACTICAL, A MOUNTABLE BERM WITH 5:1 SLOPES WILL BE PERMITTED.
- MAINTENANCE - THE ENTRANCE SHALL BE MAINTAINED IN A CONDITION WHICH WILL PREVENT TRACKING OR FLOWING OF SEDIMENT ONTO PUBLIC RIGHTS-OF-WAY, ALL SEDIMENT SPILLED, DROPPED, WASHED OR TRACKED ONTO PUBLIC RIGHTS-OF-WAY MUST BE REMOVED IMMEDIATELY.
- WHEN WASHING IS REQUIRED, IT SHALL BE DONE ON A AREA STABILIZED WITH STONE AND WHICH DRAINS INTO AN APPROVED SEDIMENT TRAPPING DEVICE.
- PERIODIC INSPECTION AND NEEDED MAINTENANCE SHALL BE PROVIDED AFTER EACH RAIN.

**4 ANTI-TRACKING PAD DETAIL**  
NOT TO SCALE



- ALL SEDIMENT & EROSION CONTROL MEASURES SHALL BE INSTALLED IN ACCORDANCE WITH THESE PLANS & DETAILS. CHANGES, OMISSIONS AND/OR OTHER ALTERATIONS CAN NOT BE MADE TO THESE PLANS WITHOUT THE CONSENT OF THE DESIGN ENGINEER.
- SILT FENCE SHALL BE INSTALLED AS SHOWN ON THIS DRAWING PRIOR TO BEGINNING ANY CLEARING, GRUBBING AND EARTHWORK.
- EXPOSED SLOPES AND ALL GRADED AREAS SHALL BE SEEDED WITH THE FOLLOWING GRASS SEED MIX IMMEDIATELY UPON COMPLETION OF ITS CONSTRUCTION, OR IF PLANNED TO BE LEFT UNDISTURBED FOR MORE THAN 21 DAYS. GRASS SEED MIX TO BE APPLIED AT A RATE OF 50 POUNDS PER ACRE IN THE FOLLOWING PROPORTIONS:

**8 TEMPORARY CONCRETE WASHOUT DETAIL**  
NOT TO SCALE

- NOTES:**
- CONCRETE WASHOUT SIGN TO BE INSTALLED WITHIN 30 FEET OF THE TEMPORARY CONCRETE WASHOUT FACILITY.
  - REMOVE HARDEN CONCRETE WHEN WITHIN 4" FROM TOP OF STRUCTURE.
  - CONSTRUCT NEW FACILITIES ONCE CURRENT FACILITIES ARE TWO-THIRDS FULL.
  - LINERS, HAYBALES, ETC SHALL BE INSPECTED FOR DAMAGE. ANY DAMAGE SHALL BE REPAIR PROMPTLY.

**Town of New Windsor**  
**Planning Board Approval**

NWPB Project No. 17-04

Tax Map Parcel No. 4-1-12.11 (2.81 Ac)

IT IS A VIOLATION OF NEW YORK STATE EDUCATION LAW FOR ANY PERSONS TO ALTER THESE PLANS, SPECIFICATIONS, OR REPORTS IN ANY WAY, UNLESS ACTING UNDER THE DIRECTION OF A LICENSED PROFESSIONAL ENGINEER OR LAND SURVEYOR.

Mark A. Day, PE	
Date:	January 15, 2019
Project No.:	May 5, 2017
Project No.:	2016:003
License No.:	069646

**M.A. DAY Engineering, PC**  
*Consulting Engineers*

3 Van Wyck  
Lane Suite 2  
Wappingers Falls, New York  
(845)-223-3202

PROJECT  
**935 Union Ave**

Town of New Windsor      Orange County, NY

DRAWING NO.  
**Erosion & Sediment Control Details**

SCALE	DESIGNED BY	DRAWING NO.
As Noted	DJL	<b>CE501</b>
DATE	CHECKED BY	16 of 16
04-07-17	DJL	







## Appendix J

# Stormtech SC-740 Construction Guide and O&M Manual





# Isolator<sup>®</sup> Row O&M Manual





## THE ISOLATOR<sup>®</sup> ROW

### INTRODUCTION

An important component of any Stormwater Pollution Prevention Plan is inspection and maintenance. The StormTech Isolator Row is a technique to inexpensively enhance Total Suspended Solids (TSS) removal and provide easy access for inspection and maintenance.

### THE ISOLATOR ROW

The Isolator Row is a row of StormTech chambers, either SC-160LP, SC-310, SC-310-3, SC-740, DC-780, MC-3500 or MC-4500 models, that is surrounded with filter fabric and connected to a closely located manhole for easy access. The fabric-wrapped chambers provide for settling and filtration of sediment as storm water rises in the Isolator Row and ultimately passes through the filter fabric. The open bottom chambers and perforated sidewalls (SC-310, SC-310-3 and SC-740 models) allow storm water to flow both vertically and horizontally out of the chambers. Sediments are captured in the Isolator Row protecting the storage areas of the adjacent stone and chambers from sediment accumulation.

Two different fabrics are used for the Isolator Row. A woven geotextile fabric is placed between the stone and the Isolator Row chambers. The tough geotextile provides a media for storm water filtration and provides a durable surface for maintenance operations. It is also designed to prevent scour of the underlying stone and remain intact during high pressure jetting. A non-woven fabric is placed over the chambers to provide a filter media for flows passing through the perforations in the sidewall of the chamber. The non-woven fabric is not required over the SC-160LP, DC-780, MC-3500 or MC-4500 models as these chambers do not have perforated side walls.

The Isolator Row is typically designed to capture the “first flush” and offers the versatility to be sized on a volume basis or flow rate basis. An upstream manhole not only provides access to the Isolator Row but typically includes a high flow weir such that storm water flowrates or volumes that exceed the capacity of the Isolator Row overtop the overflow weir and discharge through a manifold to the other chambers.

The Isolator Row may also be part of a treatment train. By treating storm water prior to entry into the chamber system, the service life can be extended and pollutants such as hydrocarbons can be captured. Pre-treatment best management practices can be as simple as deep sump catch basins, oil-water separators or can be innovative storm water treatment devices. The design of the treatment train and selection of pretreatment devices by the design engineer is often driven by regulatory requirements. Whether pretreatment is used or not, the Isolator Row is recommended by StormTech as an effective means to minimize maintenance requirements and maintenance costs.

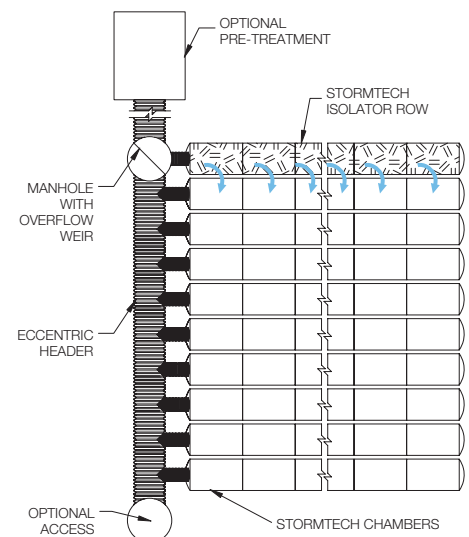
*Note: See the StormTech Design Manual for detailed information on designing inlets for a StormTech system, including the Isolator Row.*



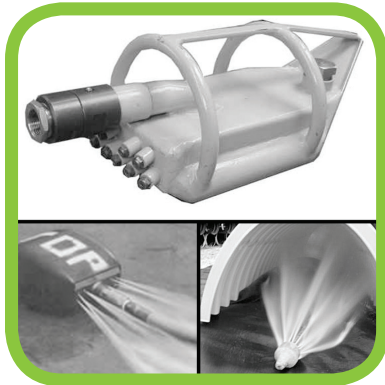
Looking down the Isolator Row from the manhole opening, woven geotextile is shown between the chamber and stone base.



StormTech Isolator Row with Overflow Spillway (not to scale)







## ISOLATOR ROW INSPECTION/MAINTENANCE

### INSPECTION

The frequency of inspection and maintenance varies by location. A routine inspection schedule needs to be established for each individual location based upon site specific variables. The type of land use (i.e. industrial, commercial, residential), anticipated pollutant load, percent imperviousness, climate, etc. all play a critical role in determining the actual frequency of inspection and maintenance practices.

At a minimum, StormTech recommends annual inspections. Initially, the Isolator Row should be inspected every 6 months for the first year of operation. For subsequent years, the inspection should be adjusted based upon previous observation of sediment deposition.

The Isolator Row incorporates a combination of standard manhole(s) and strategically located inspection ports (as needed). The inspection ports allow for easy access to the system from the surface, eliminating the need to perform a confined space entry for inspection purposes.

If upon visual inspection it is found that sediment has accumulated, a stadia rod should be inserted to determine the depth of sediment. When the average depth of sediment exceeds 3 inches throughout the length of the Isolator Row, clean-out should be performed.

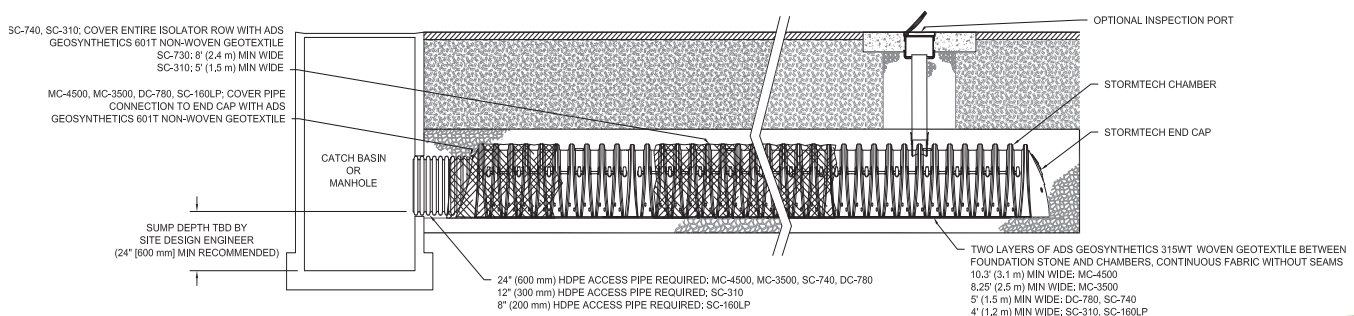
### MAINTENANCE

The Isolator Row was designed to reduce the cost of periodic maintenance. By “isolating” sediments to just one row, costs are dramatically reduced by eliminating the need to clean out each row of the entire storage bed. If inspection indicates the potential need for maintenance, access is provided via a manhole(s) located on the end(s) of the row for cleanout. If entry into the manhole is required, please follow local and OSHA rules for a confined space entries.

Maintenance is accomplished with the JetVac process. The JetVac process utilizes a high pressure water nozzle to propel itself down the Isolator Row while scouring and suspending sediments. As the nozzle is retrieved, the captured pollutants are flushed back into the manhole for vacuuming. Most sewer and pipe maintenance companies have vacuum/JetVac combination vehicles. Selection of an appropriate JetVac nozzle will improve maintenance efficiency. Fixed nozzles designed for culverts or large diameter pipe cleaning are preferable. Rear facing jets with an effective spread of at least 45” are best. Most JetVac reels have 400 feet of hose allowing maintenance of an Isolator Row up to 50 chambers long. **The JetVac process shall only be performed on StormTech Isolator Rows that have AASHTO class 1 woven geotextile (as specified by StormTech) over their angular base stone.**

### StormTech Isolator Row (not to scale)

*Note: Non-woven fabric is only required over the inlet pipe connection into the end cap for SC-160LP, DC-780, MC-3500 and MC-4500 chamber models and is not required over the entire Isolator Row.*



# ISOLATOR ROW STEP BY STEP MAINTENANCE PROCEDURES

## STEP 1

Inspect Isolator Row for sediment.

- A) Inspection ports (if present)
  - i. Remove lid from floor box frame
  - ii. Remove cap from inspection riser
  - iii. Using a flashlight and stadia rod, measure depth of sediment and record results on maintenance log.
  - iv. If sediment is at or above 3 inch depth, proceed to Step 2. If not, proceed to Step 3.
- B) All Isolator Rows
  - i. Remove cover from manhole at upstream end of Isolator Row
  - ii. Using a flashlight, inspect down Isolator Row through outlet pipe
    - 1. Mirrors on poles or cameras may be used to avoid a confined space entry
    - 2. Follow OSHA regulations for confined space entry if entering manhole
  - iii. If sediment is at or above the lower row of sidewall holes (approximately 3 inches), proceed to Step 2. If not, proceed to Step 3.

## STEP 2

Clean out Isolator Row using the JetVac process.

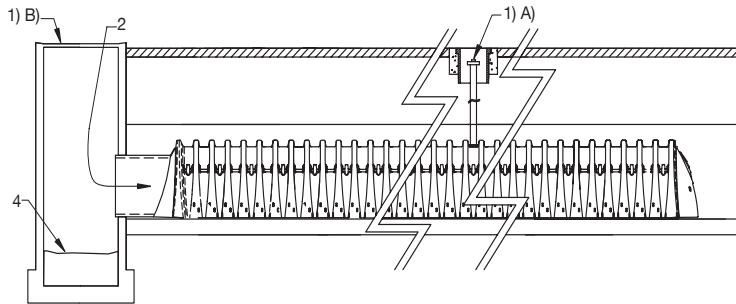
- A) A fixed floor cleaning nozzle with rear facing nozzle spread of 45 inches or more is preferable
- B) Apply multiple passes of JetVac until backflush water is clean
- C) Vacuum manhole sump as required

## STEP 3

Replace all caps, lids and covers, record observations and actions.

## STEP 4

Inspect & clean catch basins and manholes upstream of the StormTech system.



## SAMPLE MAINTENANCE LOG

Date	Stadia Rod Readings		Sediment Depth (1)-(2)	Observations/Actions	Inspector
	Fixed point to chamber bottom (1)	Fixed point to top of sediment (2)			
3/15/11	6.3 ft	none		New installation. Fixed point is CI frame at grade	DJM
9/24/11		6.2	0.1 ft	Some grit felt	SM
6/20/13		5.8	0.5 ft	Mucky feel, debris visible in manhole and in Isolator Row, maintenance due	NV
7/7/13	6.3 ft		0	System jetted and vacuumed	DJM

## StormTech Construction Guide

### REQUIRED MATERIALS AND EQUIPMENT LIST

- Acceptable fill materials per Table 1
- Woven and non-woven geotextiles
- StormTech solid end caps and pre-cored end caps
- StormTech chambers
- StormTech manifolds and fittings

### IMPORTANT NOTES:

- This installation guide provides the minimum requirements for proper installation of chambers. Non-adherence to this guide may result in damage to chambers during installation. Replacement of damaged chambers during or after backfilling is costly and very time consuming. It is recommended that all installers are familiar with this guide, and that the contractor inspects the chambers for distortion, damage and joint integrity as work progresses.
- Use of a dozer to push embedment stone between the rows of chambers may cause damage to chambers and is not an acceptable backfill method. Any chambers damaged by using the “dump and push” method are not covered under the StormTech standard warranty.
- Care should be taken in the handling of chambers and end caps. Avoid dropping, prying or excessive force on chambers during removal from pallet and initial placement.

## Requirements for System Installation



Excavate bed and prepare subgrade per engineer's plans.



Place non-woven geotextile over prepared soils and up excavation walls. Install underdrains if required.



Place clean, crushed, angular stone foundation 6" (150 mm) min. Compact to achieve a flat surface.



# Manifold, Scour Fabric and Chamber Assembly



Install manifolds and lay out woven scour geo textile at inlet rows [min. 12.5 ft (3.8 m)] at each inlet end cap. Place a continuous piece (no seams, double layer) along entire length of Isolator® Row(s).



Align the first chamber and end cap of each row with inlet pipes. Contractor may choose to postpone stone placement around end chambers and leave ends of rows open for easy inspection of chambers during the backfill process.



Continue installing chambers by overlapping chamber end corrugations. Chamber joints are labeled "Lower Joint – Overlap Here" and "Build this direction – Upper Joint". Be sure that the chamber placement does not exceed the reach of the construction equipment used to place the stone. Maintain minimum 6" (150 mm) spacing between rows

## Attaching the End Caps



Lift the end of the chamber a few inches off the ground. With the curved face of the end cap facing outward, place the end cap into the chamber's end corrugation.

## Prefabricated End Caps



24" (600 mm) inlets are the maximum size that can fit into a SC-740/DC-780 end cap and must be prefabricated with a 24" (600 mm) pipe stub. SC-310 chambers with a 12" (300 mm) inlet pipe must use a prefabricated end cap with a 12" (300 mm) pipe stub.

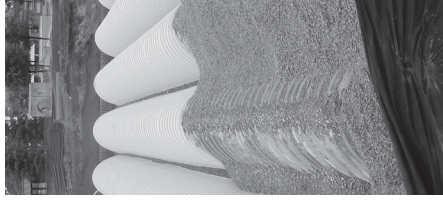
## Isolator Row



Place two continuous layers of ADS Woven fabric between the foundation stone and the isolator row chambers, making sure the fabric lays flat and extends the entire width of the chamber feet. Drape a strip of ADS non-woven geotextile over the row of chambers (not required over DC-780). This is the same type of non-woven geotextile used as a separation layer around the angular stone of the StormTech system.



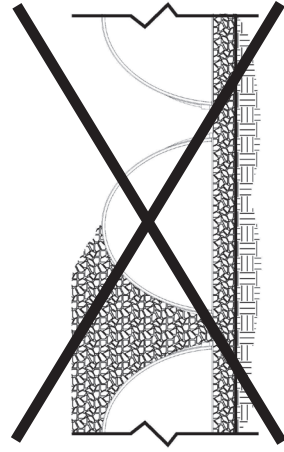
## Initial Anchoring of Chambers – Embedment Stone



Initial embedment shall be spotted along the centerline of the chamber evenly anchoring the lower portion of the chamber. This is best accomplished with a stone conveyor or excavator reaching along the row.

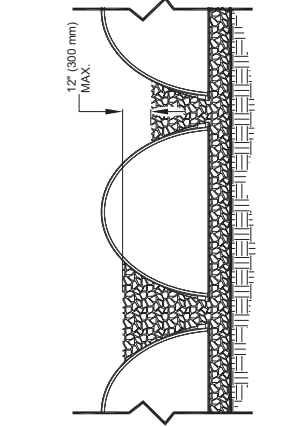
No equipment shall be operated on the bed at this stage of the installation. Excavators must be located off the bed. Dump trucks shall not dump stone directly on to the bed. Dozers or loaders are not allowed on the bed at this time.

## Backfill of Chambers – Embedment Stone



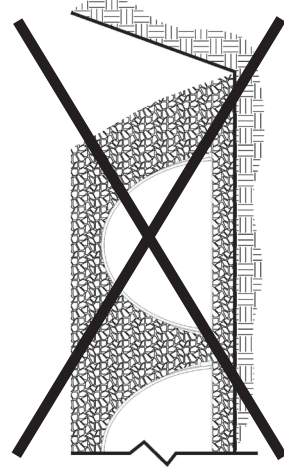
UNEVEN BACKFILL

Backfill chambers evenly. Stone column height should never differ by more than 12" (300 mm) between adjacent chamber rows or between chamber rows and perimeter.



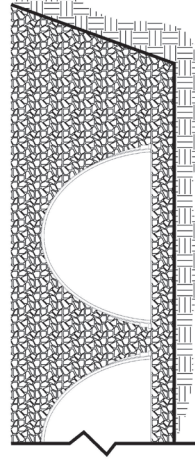
EVEN BACKFILL

Backfill chambers evenly. Stone column height should never differ by more than 12" (300 mm) between adjacent chamber rows or between chamber rows and perimeter.



PERIMETER NOT BACKFILLED

Perimeter stone must be brought up evenly with chamber rows. Perimeter must be fully backfilled, with stone extended horizontally to the excavation wall.



PERIMETER FULLY BACKFILLED



## Backfill - Embedment Stone & Cover Stone

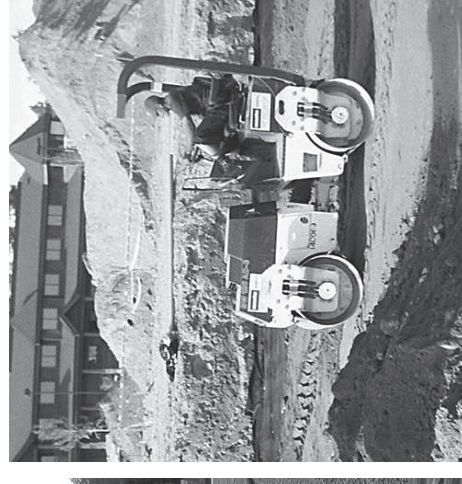


Continue evenly backfilling between rows and around perimeter until embedment stone reaches tops of chambers. Perimeter stone must extend horizontally to the excavation wall for both straight or sloped sidewalls. **Only after chambers have been backfilled to top of chamber and with a minimum 6" (150 mm) of cover stone on top of chambers can small dozers be used over the chambers for backfilling remaining cover stone.**



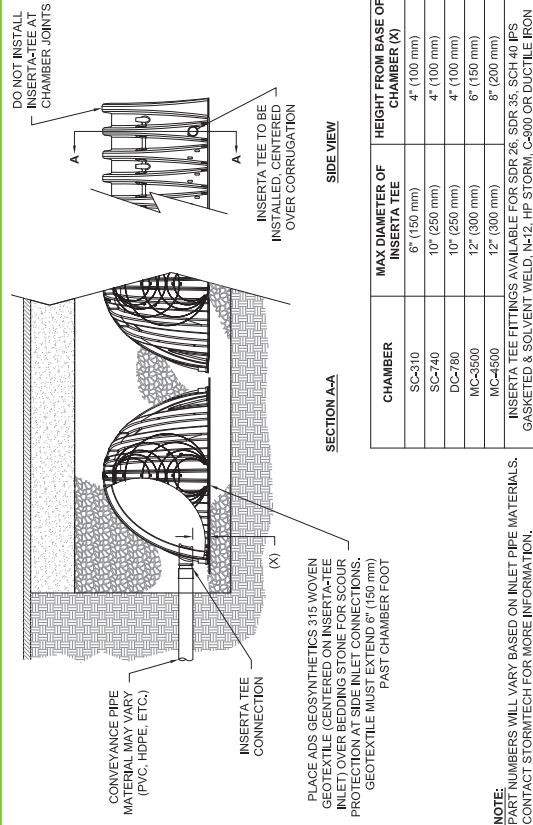
Small dozers and skid loaders may be used to finish grading stone backfill in accordance with ground pressure limits in Table 2. They must push material parallel to rows only. Never push perpendicular to rows. StormTech recommends that the contractor inspect chambers before placing final backfill. Any chambers damaged by construction shall be removed and replaced.

## Final Backfill of Chambers – Fill Material

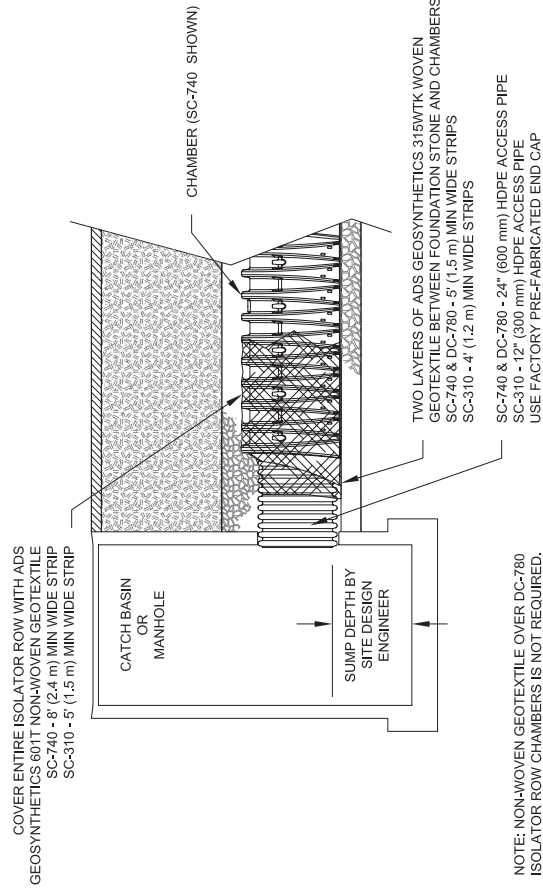


Install non-woven geotextile over stone. Geotextile must overlap 24" (600 mm) min. where edges meet. Compact each lift of backfill as specified in the site design engineer's drawings. Roller travel parallel with rows.

## Inserta Tee Detail



## StormTech Isolator Row Detail



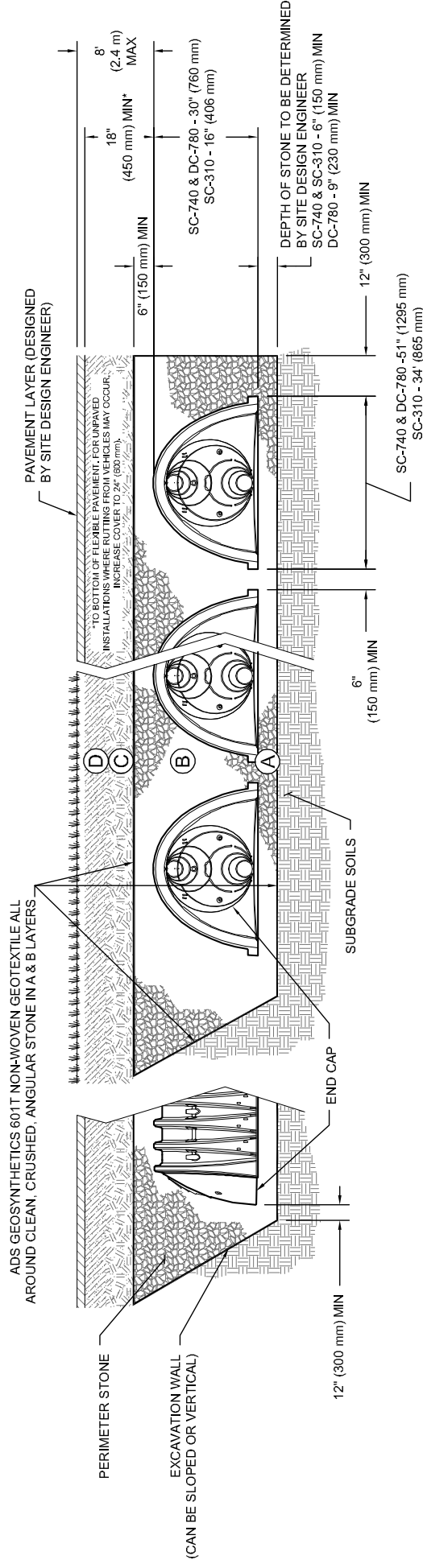
**Table 1 - Acceptable Fill Materials**

Material Location	Description	AASHTO M43 Designation <sup>1</sup>	Compaction/Density Requirement
<b>D Final Fill:</b> Fill Material for layer 'D' starts from the top of the 'C' layer to the bottom of flexible pavement or unpaved finished grade above. Note that the pavement subbase may be part of the 'D' layer.	Any soil/rock materials, native soils or per engineer's plans. Check plans for pavement subgrade requirements.	N/A	Prepare per site design engineer's plans. Paved installations may have stringent material and preparation requirements.
<b>C Initial Fill:</b> Fill Material for layer 'C' starts from the top of the embedment stone ('B' layer) to 18" (450 mm) above the top of the chamber. Note that pavement subbase may be part of the 'C' layer.	Granular well-graded soil/aggregate mixtures, <35% fines or processed aggregate. Most pavement subbase materials can be used in lieu of this layer.	AASHTO M45 A-1, A-2, A-3 or AASHTO M431 3, 357, 4, 467, 5, 56, 57, 6, 67, 68, 7, 78, 8, 89, 9, 10	Begin compaction after min. 12" (300 mm) of material over the chambers is reached. Compact additional layers in 6" (150 mm) max. lifts to a min. 95% Proctor density for well-graded material and 95% relative density for processed aggregate materials. Roller gross vehicle weight not to exceed 12,000 lbs (53 kN). Dynamic force not to exceed 20,000 lbs (89 kN).
<b>B Embedment Stone:</b> Embedment Stone surrounding chambers from the foundation stone to the 'C' layer above.	Clean, crushed, angular stone	AASHTO M43 <sup>1</sup> 3, 357, 4, 467, 5, 56, 57	No compaction required.
<b>A Foundation Stone:</b> Foundation Stone below the chambers from the subgrade up to the foot (bottom) of the chamber.	Clean, crushed, angular stone,	AASHTO M43 <sup>1</sup> 3, 357, 4, 467, 5, 56, 57	Place and compact in 6" (150 mm) lifts using two full coverages with a vibratory compactor. <sup>2,3</sup>

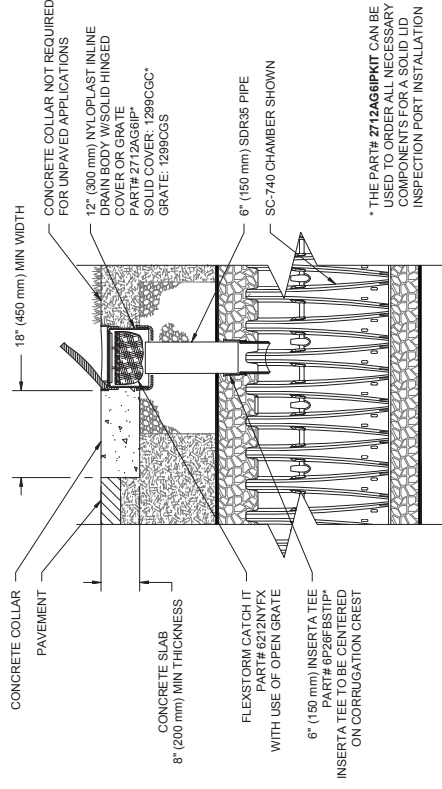
**PLEASE NOTE:**

- 1. The listed AASHTO designations are for gradations only. The stone must also be clean, crushed, angular. For example, a specification for #4 stone would state: "clean, crushed, angular no. 4 (AASHTO M43) stone".*
- 2. StormTech compaction requirements are met for 'A' location materials when placed and compacted in 6" (150 mm) (max) lifts using two full coverages with a vibratory compactor.*
- 3. Where infiltration surfaces may be comprised by compaction, for standard installations and standard design load conditions, a flat surface may be achieved by raking or dragging without compaction equipment. For special load designs, contact StormTech for compaction requirements.*

**Figure 2 - Fill Material Locations**



**Figure 1 - Inspection Port Detail**





**NOTES:**

1. 36" (900 mm) of stabilized cover materials over the chambers is required for full dump truck travel and dumping.
2. During paving operations, dump truck axle loads on 18" (450 mm) of cover may be necessary. Precautions should be taken to avoid rutting of the road base layer, to ensure that compaction requirements have been met, and that a minimum of 18" (450 mm) of cover exists over the chambers. Contact StormTech for additional guidance on allowable axle loads during paving.
3. Ground pressure for track dozers is the vehicle operating weight divided by total ground contact area for both tracks. Excavators will exert higher ground pressures based on loaded bucket weight and boom extension.
4. Mini-excavators (< 8,000lbs/3,628 kg) can be used with at least 12" (300 mm) of stone over the chambers and are limited by the maximum ground pressures in Table 2 based on a full bucket at maximum boom extension.
5. Storage of materials such as construction materials, equipment, spoils, etc. should not be located over the StormTech system. The use of equipment over the StormTech system not covered in Table 2 (ex. soil mixing equipment, cranes, etc) is limited. Please contact StormTech for more information.
6. Allowable track loads based on vehicle travel only. Excavators shall not operate on chamber beds until the total backfill reaches 3 feet (900 mm) over the entire bed.

**Table 2 - Maximum Allowable Construction Vehicle Loads<sup>5</sup>**

Material Location	Fill Depth over Chambers in. [mm]	Maximum Allowable Wheel Loads		Maximum Allowable Track Loads <sup>6</sup>		Maximum Allowable Roller Loads Max Drum Weight or Dynamic Force lbs [kN]
		Max Axle Load for Trucks lbs [kN]	Max Wheel Load for Loaders lbs [kN]	Track Width in. [mm]	Max Ground Pressure psf [kPa]	
Ⓐ Final Fill Material	36" [900] Compacted	32,000 [142]	16,000 [71]	12" [305]	3420 [164]	38,000 [169]
				18" [457]	2350 [113]	
				24" [610]	1850 [89]	
Ⓑ Initial Fill Material	24" [600] Compacted	32,000 [142]	16,000 [71]	12" [305]	2480 [119]	20,000 [89]
				18" [457]	1770 [85]	
				24" [610]	1430 [68]	
Ⓒ Embedment Stone	24" [600] Loose/Dumped	32,000 [142]	16,000 [71]	12" [305]	2245 [107]	Roller gross vehicle weight not to exceed 12,000 lbs. [53 kN]
				18" [457]	1625 [78]	
				24" [610]	1325 [63]	
Ⓓ Final Fill Material	18" [450]	32,000 [142]	16,000 [71]	12" [305]	2010 [96]	Roller gross vehicle weight not to exceed 12,000 lbs. [53 kN]
				18" [457]	1480 [71]	
				24" [610]	1220 [58]	
Ⓔ Embedment Stone	12" [300]	16,000 [71]	NOT ALLOWED	12" [305]	1540 [74]	Roller gross vehicle weight not to exceed 12,000 lbs. [53 kN]
				18" [457]	1190 [57]	
				24" [610]	1010 [48]	
Ⓕ Foundation Stone	6" [150]	8,000 [35]	NOT ALLOWED	12" [305]	1070 [51]	NOT ALLOWED
				18" [457]	900 [43]	
				24" [610]	800 [38]	
Ⓖ Final Fill Material	36" [914]	32,000 [142]	16,000 [71]	12" [305]	2010 [96]	Roller gross vehicle weight not to exceed 12,000 lbs. [53 kN]
				18" [457]	1480 [71]	
				24" [610]	1220 [58]	

**Table 3 - Placement Methods and Descriptions**

Material Location	Placement Methods/ Restrictions	Wheel Load Restrictions	Track Load Restrictions	Roller Load Restrictions
		See Table 2 for Maximum Construction Loads		
Ⓐ Final Fill Material	A variety of placement methods may be used. All construction loads must not exceed the maximum limits in Table 2.	36" (900 mm) minimum cover required for dump trucks to dump over chambers.	Dozers to push parallel to rows until 36" (900mm) compacted cover is reached. <sup>4</sup>	Roller travel parallel to rows only until 36" (900 mm) compacted cover is reached.
Ⓑ Initial Fill Material	Excavator positioned off bed recommended. Small excavator allowed over chambers. Small dozer allowed.	Asphalt can be dumped into paver when compacted pavement subbase reaches 18" (450 mm) above top of chambers.	Small LGP track dozers & skid loaders allowed to grade cover stone with at least 6" (150 mm) stone under tracks at all times. Equipment must push parallel to rows at all times.	Use dynamic force of roller only after compacted fill over chambers. Roller travel parallel to chamber rows only.
Ⓒ Embedment Stone	No equipment allowed on bare chambers. Use excavator or stone conveyor positioned off bed or on foundation stone to evenly fill around all chambers to at least the top of chambers.	No wheel loads allowed. Material must be placed outside the limits of the chamber bed.	No tracked equipment is allowed on chambers until a min. 6" (150 mm) cover stone is in place.	No rollers allowed.
Ⓓ Foundation Stone	No StormTech restrictions. Contractor responsible for any conditions or requirements by others relative to subgrade bearing capacity, dewatering or protection of subgrade.			

ADS "Terms and Conditions of Sale" are available on the ADS website, [www.ads-pipe.com](http://www.ads-pipe.com). Advanced Drainage Systems, the ADS logo, and the green stripe are registered trademarks of Advanced Drainage Systems, Inc. StormTech® and the Isolator® Row are registered trademarks of StormTech, Inc #11010 07/17 CS

©2017 Advanced Drainage Systems, Inc.





## Appendix K

# Construction Inspection Log Book



# **M. A. Day Engineering, PC**

---

3 Van Wyck Lane  
Suite 2  
Wappingers Falls, New York 12590  
Phone: 845-223-3202  
Fax: 845-223-3206

## **Construction Site Inspection Log Book**

**for**

## **Temporary Erosion & Sediment Controls**

**in use on**

## **935 Union Avenue.**

**Location:**  
935 Union Avenue  
Town of New Windsor  
County of Orange



## APPENDIX H

### STATE POLLUTANT DISCHARGE ELIMINATION SYSTEM FOR CONSTRUCTION ACTIVITIES CONSTRUCTION SITE LOG BOOK

#### Table of Contents

---

- I. Pre-Construction Meeting Documents
  - a. Preamble to Site Assessment and Inspections
  - b. Operator's Certification
  - c. Qualified Professional's Credentials & Certification
  - d. Pre-Construction Site Assessment Checklist
  
- II. Construction Duration Inspections
  - a. Directions
  - b. Modification to the SWPPP
  
- III. Monthly Summary Reports
  
- IV. Monitoring, Reporting, and Three-Month Status Reports
  - a. Operator's Compliance Response Form

Properly completing forms such as those contained in Appendix H meet the inspection requirement of NYS-DEC SPDES GP for Construction Activities. Completed forms shall be kept on site at all times and made available to authorities upon request.

## I. PRE-CONSTRUCTION MEETING DOCUMENTS

**Project Name** \_\_\_\_\_  
**Permit No.** \_\_\_\_\_ **Date of Authorization** \_\_\_\_\_  
**Name of Operator** \_\_\_\_\_  
**Prime Contractor** \_\_\_\_\_

### a. Preamble to Site Assessment and Inspections

The Following Information To Be Read By All Person's Involved in The Construction of Stormwater Related Activities:

The Operator agrees to have a qualified professional<sup>1</sup> conduct an assessment of the site prior to the commencement of construction<sup>2</sup> and certify in this inspection report that the appropriate erosion and sediment controls described in the SWPPP have been adequately installed or implemented to ensure overall preparedness of the site for the commencement of construction.

Prior to the commencement of construction, the Operator shall certify in this site logbook that the SWPPP has been prepared in accordance with the State's standards and meets all Federal, State and local erosion and sediment control requirements.

When construction starts, site inspections shall be conducted by the qualified professional at least every 7 calendar days and within 24 hours of the end of a storm event of 0.5 inches or greater (Construction Duration Inspections). The Operator shall maintain a record of all inspection reports in this site logbook. The site logbook shall be maintained on site and be made available to the permitting authorities upon request. The Operator shall post at the site, in a publicly accessible location, a summary of the site inspection activities on a monthly basis (Monthly Summary Report).

The operator shall also prepare a written summary of compliance with this general permit at a minimum frequency of every three months (Operator's Compliance Response Form), while coverage exists. The summary should address the status of achieving each component of the SWPPP.

Prior to filing the Notice of Termination or the end of permit term, the Operator shall have a qualified professional perform a final site inspection. The qualified professional shall certify that the site has undergone final stabilization<sup>3</sup> using either vegetative or structural stabilization methods and that all temporary erosion and sediment controls (such as silt fencing) not needed for long-term erosion control have been removed. In addition, the Operator must identify and certify that all permanent structures described in the SWPPP have been constructed and provide the owner(s) with an operation and maintenance plan that ensures the structure(s) continuously functions as designed.

1 "Qualified Professional means a person knowledgeable in the principles and practice of erosion and sediment controls, such as a Certified Professional in Erosion and Sediment Control (CPESC), soil scientist, licensed engineer or someone working under the direction and supervision of a licensed engineer (person must have experience in the principles and practices of erosion and sediment control).

2 "Commencement of construction" means the initial removal of vegetation and disturbance of soils associated with clearing, grading or excavating activities or other construction activities.

3 "Final stabilization" means that all soil-disturbing activities at the site have been completed and a uniform, perennial vegetative cover with a density of eighty (80) percent has been established or equivalent stabilization measures (such as the use of mulches or geotextiles) have been employed on all unpaved areas and areas not covered by permanent structures.

**b. Operators Certification**

"I certify under penalty of law that this document and all attachments were prepared under my direction or supervision in accordance with a system designed to assure that qualified personnel properly gathered and evaluated the information submitted. Based on my inquiry of the person or persons who manage the system, or those persons directly responsible for gathering the information, the information submitted is, to the best of my knowledge and belief, true, accurate, and complete. Further, I hereby certify that the SWPPP meets all Federal, State, and local erosion and sediment control requirements. I am aware that false statements made herein are punishable as a class A misdemeanor pursuant to Section 210.45 of the Penal Law.

**Name (please print):** \_\_\_\_\_

**Title** \_\_\_\_\_ **Date:** \_\_\_\_\_

**Address:** \_\_\_\_\_

**Phone:** \_\_\_\_\_ **Email:** \_\_\_\_\_

**Signature:** \_\_\_\_\_

**c. Qualified Professional's Credentials & Certification**

"I hereby certify that I meet the criteria set forth in the General Permit to conduct site inspections for this project and that the appropriate erosion and sediment controls described in the SWPPP and as described in the following Pre-construction Site Assessment Checklist have been adequately installed or implemented, ensuring the overall preparedness of this site for the commencement of construction."

**Name (please print):** \_\_\_\_\_

**Title** \_\_\_\_\_ **Date:** \_\_\_\_\_

**Address:** \_\_\_\_\_

**Phone:** \_\_\_\_\_ **Email:** \_\_\_\_\_

**Signature:** \_\_\_\_\_

**d. Pre-construction Site Assessment Checklist**

**(NOTE: Provide comments below as necessary)**

1. Notice of Intent, SWPPP, and Contractors Certification:

**Yes No NA**

- Has a Notice of Intent been filed with the NYS Department of Conservation?
- Is the SWPPP on-site? Where? \_\_\_\_\_
- Is the Plan current? What is the latest revision date? \_\_\_\_\_
- Is a copy of the NOI (with brief description) onsite? Where? \_\_\_\_\_
- Have all contractors involved with stormwater related activities signed a contractor's certification?

2. Resource Protection

**Yes No NA**

- Are construction limits clearly flagged or fenced?
- Important trees and associated rooting zones, on-site septic system absorption fields, existing vegetated areas suitable for filter strips, especially in perimeter areas, have been flagged for protection.
- Creek crossings installed prior to land-disturbing activity, including clearing and blasting.

3. Surface Water Protection

**Yes No NA**

- Clean stormwater runoff has been diverted from areas to be disturbed.
- Bodies of water located either on site or in the vicinity of the site have been identified and protected.
- Appropriate practices to protect on-site or downstream surface water are installed.
- Are clearing and grading operations divided into areas <5 acres?

4. Stabilized Construction Entrance

**Yes No NA**

- A temporary construction entrance to capture mud and debris from construction vehicles before they enter the public highway has been installed.
- Other access areas (entrances, construction routes, equipment parking areas) are stabilized immediately as work takes place with gravel or other cover.
- Sediment tracked onto public streets is removed or cleaned on a regular basis.

5. Perimeter Sediment Controls

**Yes No NA**

- Silt fence material and installation comply with the standard drawing and specifications.
- Silt fences are installed at appropriate spacing intervals
- Sediment/detention basin was installed as first land disturbing activity.
- Sediment traps and barriers are installed.

6. Pollution Prevention for Waste and Hazardous Materials

**Yes No NA**

- The Operator or designated representative has been assigned to implement the spill prevention avoidance and response plan.
- The plan is contained in the SWPPP on page \_\_\_\_\_
- Appropriate materials to control spills are onsite. Where? \_\_\_\_\_



## II. CONSTRUCTION DURATION INSPECTIONS

### a. Directions:

**Inspection Forms will be filled out during the entire construction phase of the project.**

Required Elements:

- (1) On a site map, indicate the extent of all disturbed site areas and drainage pathways. Indicate site areas that are expected to undergo initial disturbance or significant site work within the next 14-day period;
- (2) Indicate on a site map all areas of the site that have undergone temporary or permanent stabilization;
- (3) Indicate all disturbed site areas that have not undergone active site work during the previous 14-day period;
- (4) Inspect all sediment control practices and record the approximate degree of sediment accumulation as a percentage of sediment storage volume (for example, 10 percent, 20 percent, 50 percent);
- (5) Inspect all erosion and sediment control practices and record all maintenance requirements such as verifying the integrity of barrier or diversion systems (earthen berms or silt fencing) and containment systems (sediment basins and sediment traps). Identify any evidence of rill or gully erosion occurring on slopes and any loss of stabilizing vegetation or seeding/mulching. Document any excessive deposition of sediment or ponding water along barrier or diversion systems. Record the depth of sediment within containment structures, any erosion near outlet and overflow structures, and verify the ability of rock filters around perforated riser pipes to pass water; and
- (6) Immediately report to the Operator any deficiencies that are identified with the implementation of the SWPPP.

**SITE PLAN/SKETCH**

---

**Inspector (print name)**

---

**Date of Inspection**

---

**Qualified Professional (print name)**

---

**Qualified Professional Signature**

The above signed acknowledges that, to the best of his/her knowledge, all information provided on the forms is accurate and complete.

**Maintaining Water Quality**

**Yes No NA**

- Is there an increase in turbidity causing a substantial visible contrast to natural conditions?
- Is there residue from oil and floating substances, visible oil film, or globules or grease?
- All disturbance is within the limits of the approved plans.
- Have receiving lake/bay, stream, and/or wetland been impacted by silt from project?

**Housekeeping**

1. General Site Conditions

**Yes No NA**

- Is construction site litter and debris appropriately managed?
- Are facilities and equipment necessary for implementation of erosion and sediment control in working order and/or properly maintained?
- Is construction impacting the adjacent property?
- Is dust adequately controlled?

2. Temporary Stream Crossing

**Yes No NA**

- Maximum diameter pipes necessary to span creek without dredging are installed.
- Installed non-woven geotextile fabric beneath approaches.
- Is fill composed of aggregate (no earth or soil)?
- Rock on approaches is clean enough to remove mud from vehicles & prevent sediment from entering stream during high flow.

**Runoff Control Practices**

1. Excavation Dewatering

**Yes No NA**

- Upstream and downstream berms (sandbags, inflatable dams, etc.) are installed per plan.
- Clean water from upstream pool is being pumped to the downstream pool.
- Sediment laden water from work area is being discharged to a silt-trapping device.
- Constructed upstream berm with one-foot minimum freeboard.

2. Level Spreader

**Yes No NA**

- Installed per plan.
- Constructed on undisturbed soil, not on fill, receiving only clear, non-sediment laden flow.
- Flow sheets out of level spreader without erosion on downstream edge.

3. Interceptor Dikes and Swales

**Yes No NA**

- Installed per plan with minimum side slopes 2H:1V or flatter.
- Stabilized by geotextile fabric, seed, or mulch with no erosion occurring.
- Sediment-laden runoff directed to sediment trapping structure

**CONSTRUCTION DURATION INSPECTIONS**  
**Runoff Control Practices (continued)**

4. Stone Check Dam

**Yes No NA**

- Is channel stable? (flow is not eroding soil underneath or around the structure).
- Check is in good condition (rocks in place and no permanent pools behind the structure).
- Has accumulated sediment been removed?.

5. Rock Outlet Protection

**Yes No NA**

- Installed per plan.
- Installed concurrently with pipe installation.

**Soil Stabilization**

1. Topsoil and Spoil Stockpiles

**Yes No NA**

- Stockpiles are stabilized with vegetation and/or mulch.
- Sediment control is installed at the toe of the slope.

2. Revegetation

**Yes No NA**

- Temporary seedings and mulch have been applied to idle areas.
- 4 inches minimum of topsoil has been applied under permanent seedings

**Sediment Control Practices**

1. Stabilized Construction Entrance

**Yes No NA**

- Stone is clean enough to effectively remove mud from vehicles.
- Installed per standards and specifications?
- Does all traffic use the stabilized entrance to enter and leave site?
- Is adequate drainage provided to prevent ponding at entrance?

2. Silt Fence

**Yes No NA**

- Installed on Contour, 10 feet from toe of slope (not across conveyance channels).
  - Joints constructed by wrapping the two ends together for continuous support.
  - Fabric buried 6 inches minimum.
  - Posts are stable, fabric is tight and without rips or frayed areas.
- Sediment accumulation is \_\_\_% of design capacity.

**Sediment Control Practices (continued)**

**3. Storm Drain Inlet Protection (Use for Stone & Block; Filter Fabric; Curb; or, Excavated practices)**

**Yes No NA**

- Installed concrete blocks lengthwise so open ends face outward, not upward.
  - Placed wire screen between No. 3 crushed stone and concrete blocks.
  - Drainage area is 1acre or less.
  - Excavated area is 900 cubic feet.
  - Excavated side slopes should be 2:1.
  - 2" x 4" frame is constructed and structurally sound.
  - Posts 3-foot maximum spacing between posts.
  - Fabric is embedded 1 to 1.5 feet below ground and secured to frame/posts with staples at max 8-inch spacing.
  - Posts are stable, fabric is tight and without rips or frayed areas.
- Sediment accumulation \_\_\_% of design capacity.

**4. Temporary Sediment Trap**

**Yes No NA**

- Outlet structure is constructed per the approved plan or drawing.
  - Geotextile fabric has been placed beneath rock fill.
- Sediment accumulation is \_\_\_% of design capacity.

**5. Temporary Sediment Basin**

**Yes No NA**

- Basin and outlet structure constructed per the approved plan.
  - Basin side slopes are stabilized with seed/mulch.
  - Drainage structure flushed and basin surface restored upon removal of sediment basin facility.
- Sediment accumulation is \_\_\_% of design capacity.

Note: Not all erosion and sediment control practices are included in this listing. Add additional pages to this list as required by site specific design.  
 Construction inspection checklists for post-development stormwater management practices can be found in Appendix F of the New York Stormwater Management Design Manual.









# AKRF, Inc. Traffic Study



## **935 Union Avenue Traffic Impact Study (TIS)**

---

### **A. INTRODUCTION**

This Traffic Impact Study (TIS) provides a detailed traffic analysis that was completed to assess the potential traffic and transportation impacts of a new 93 room hotel (the “Proposed Project”), located at 935 Union Avenue adjacent to the Days Inn and Ikaros Diner at the site of the vacant Steak and Stein restaurant.

Potential impacts of the Proposed Project were analyzed using the 2010 Highway Capacity Manual (HCM) methodology (Synchro 10 software) to calculate existing and future traffic operating conditions (Level of Service and average delay) at each of the Study Area intersections.

The TIS describes traffic operations for existing conditions within the Study Area and for conditions in the future without the Proposed Project (the “No Build” analysis), and in the future with the Proposed Project (the “Build” analysis).

### **B. EXISTING CONDITIONS**

#### **STUDY AREA AND DATA COLLECTION PROGRAM**

To assess the traffic impacts associated with the Proposed Project, a study area was identified that considered key intersections that might be affected by Project-generated trips. A total of 3 locations were identified for analysis. These intersections are:

1. Union Avenue (NYS Route 300) and Little Britain Road (NYS Route 207/300)
2. Union Avenue and Days Inn/Diner Driveway
3. Union Avenue and Liner Road

Existing traffic conditions at the three Study Area intersections were established based on traffic counts conducted in January and February, 2018. Manual turning movement counts at all the Study Area intersections, and vehicle classification counts at key locations were collected during the weekday AM (7:00 AM – 9:00 AM), PM (4:00 PM – 6:00 PM), and Saturday (10:00 AM – 2:00 PM) peak periods. Field inventories of roadway geometry were also conducted and signal timing plans were obtained from New York State Department of Transportation (NYSDOT) to provide the appropriate inputs to the operational analyses.

In addition to the manual turning movement counts at Study Area intersections, Automatic Traffic Recorder (ATR) counts were conducted for one full week at Union Avenue, just north of Little Britain Road (Route 300). Data collection sheets are provided in **Appendix A**.

#### **ROADWAY AND INTERSECTION CHARACTERISTICS**

The following is a brief description of the major roadways and intersections within the study area.

### *Union Avenue (NYS Route 300)*

NYS Route 300 is classified by NYSDOT as a minor arterial roadway that generally traverses in a north-south direction, and is also designated as Union Avenue in the vicinity of the Study Area (from Little Britain Road to Liner Road). Union Avenue is under the jurisdiction of NYSDOT and provides five travel lanes (two northbound, two southbound and one two-way left-turn lane) in the study area. At its intersection with Little Britain Road, Union Avenue provides two left-turn lanes and one right-turn lane. Union Avenue has a posted speed limit of 45 mph in the study area. Based on field observations, the pavement along the Union Avenue in the study area is in good condition.

### *Little Britain Road (NYS Route 207)*

Little Britain Road (NYS Route 207) is classified by NYSDOT as a minor arterial roadway that generally traverses in an east-west direction. Little Britain Road is under the jurisdiction of NYSDOT. Little Britain Road generally provides one moving lane in each direction within the study area. At the signalized intersection with Union Avenue, Little Britain Road provides a left turn lane and a through lane at its eastbound approach and a right turn lane and a through lane at its westbound approach. Little Britain Road has a posted speed limit of 45 mph in the study area. Based on field observations, the pavement along the Little Britain Road in the study area is in good condition.

### *Liner Road*

Liner Road is a local, town-maintained roadway that generally traverses in an east-west direction. Liner Road provide one moving lane in each direction from Union Avenue to its termination just east of Interstate 87. At its intersection with Union Avenue, Liner Road provides a left turn lane and a right turn lane at its eastbound. Based on field observations, the pavement along the Little Britain Road in the study area is in good condition.

## **TRAFFIC CONDITIONS**

### *PEAK HOURS AND TRAFFIC VOLUMES*

Based on a review of the traffic count data, the peak hours for the study area were determined to be as follows:

- Weekday AM Peak Hour – 8:00 AM to 9:00 AM
- Weekday PM Peak Hour – 4:30 PM to 5:30 PM
- Saturday Peak Hour – 11:15 AM to 12:15 PM

**Figures 1 through 3** show the roadway volumes at the study area intersections for existing conditions for the peak hours analyzed. In the study area, the two-way traffic volumes range from approximately 1,497 to 2,042 vehicles per hour (vph) along Little Britain Road and 1,598 to 1,951 vph along the Union Avenue.

### *CAPACITY ANALYSIS METHODOLOGY*

#### *Signalized Intersections*

The operation of signalized intersections in the Study Area was analyzed using the Synchro 10 traffic software applying the methodologies presented in the 2010 *Highway Capacity Manual*

(HCM2010). This procedure evaluates signalized intersections for average control delay per vehicle and level of service (LOS). Signal timing and phasing plan for the signalized intersection within the Study Area (Union Avenue and Little Britain Road) was obtained from NYSDOT.

LOS can be characterized for the entire intersection, each intersection approach, and each lane group. Control delay alone is used to characterize LOS for the entire intersection or an approach. Control delay and volume-to-capacity (v/c) ratio are used to characterize LOS for a lane group. Delay quantifies the increase in travel time due to traffic signal control. It is also a surrogate measure of driver discomfort and fuel consumption. The volume-to-capacity ratio quantifies the degree to which a phase's capacity is utilized by a lane group.

LOS A describes operation with a control delay of 10 seconds per vehicle or less and a volume-to-capacity ratio no greater than 1.0. This level is typically assigned when the volume-to-capacity ratio is low and either progression is exceptionally favorable or the cycle length is very short. If it is due to favorable progression, most vehicles arrive during the green indication and travel through the intersection without stopping.

LOS B describes operation with control delay between 10 and 20 seconds per vehicle and a volume-to-capacity ratio no greater than 1.0. This level is typically assigned when the volume-to-capacity ratio is low and either progression is highly favorable or the cycle length is short. More vehicles stop than with LOS A.

LOS C describes operation with control delay between 20 and 35 seconds per vehicle and a volume-to-capacity ratio no greater than 1.0. This level is typically assigned when the volume-to-capacity ratio is favorable or the cycle length is moderate. Individual cycle failures (i.e., one or more queued vehicles are not able to depart as a result of insufficient capacity during the cycle) may appear at this level. The number of vehicles stopping is significant, although many vehicles still pass through the intersection without stopping.

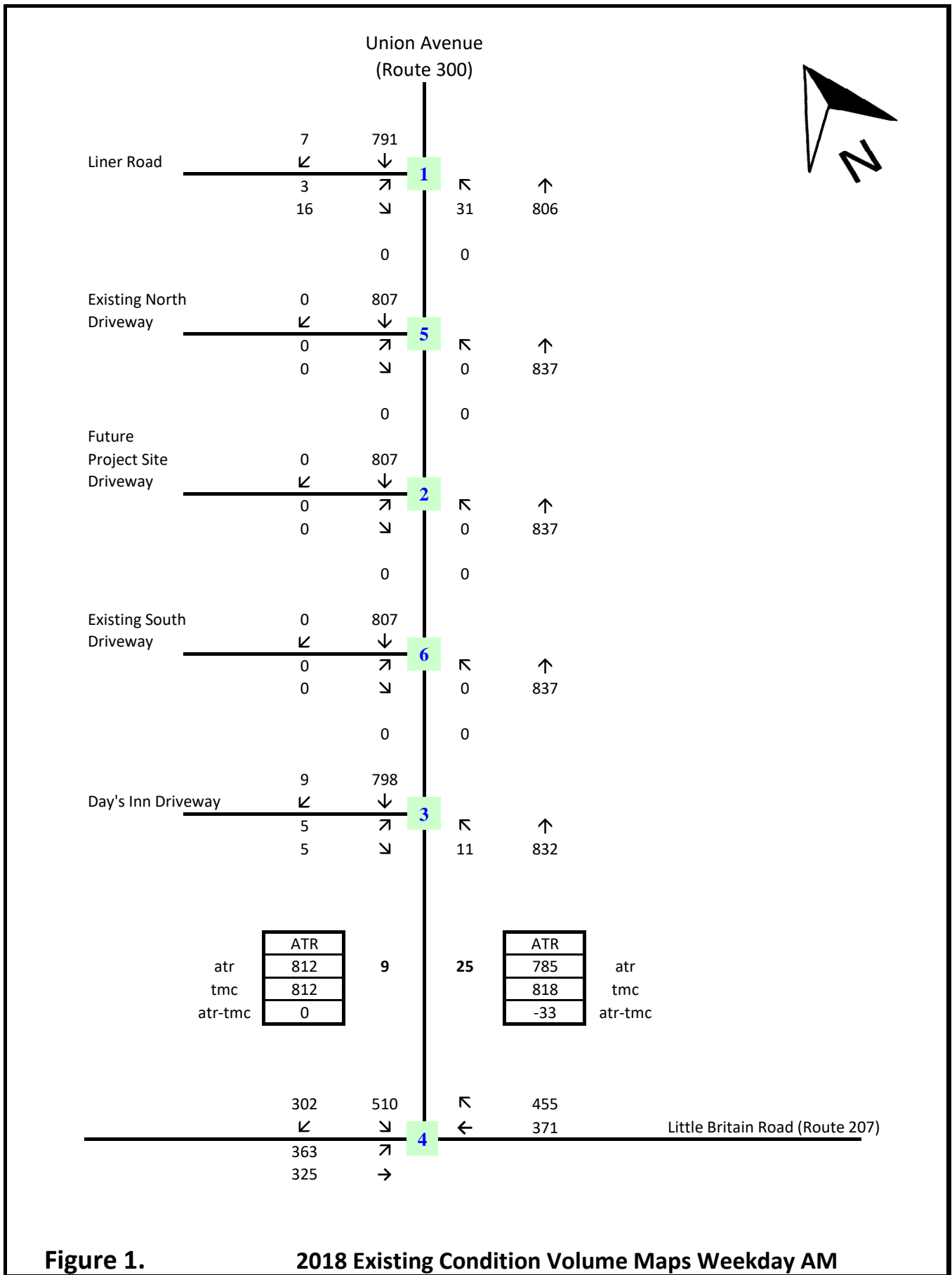
LOS D describes operation with control delay between 35 and 55 seconds per vehicle and a volume-to-capacity ratio no greater than 1.0. This level is typically assigned when the volume-to-capacity ratio is high and either progression is ineffective or the cycle length is long. Many vehicles stop and individual cycle failures are noticeable.

LOS E describes operation with control delay between 55 and 80 seconds per vehicle and a volume-to-capacity ratio no greater than 1.0. This level is typically assigned when the volume-to-capacity ratio is high, progression is unfavorable, and the cycle length is long. Individual cycle failures are frequent.

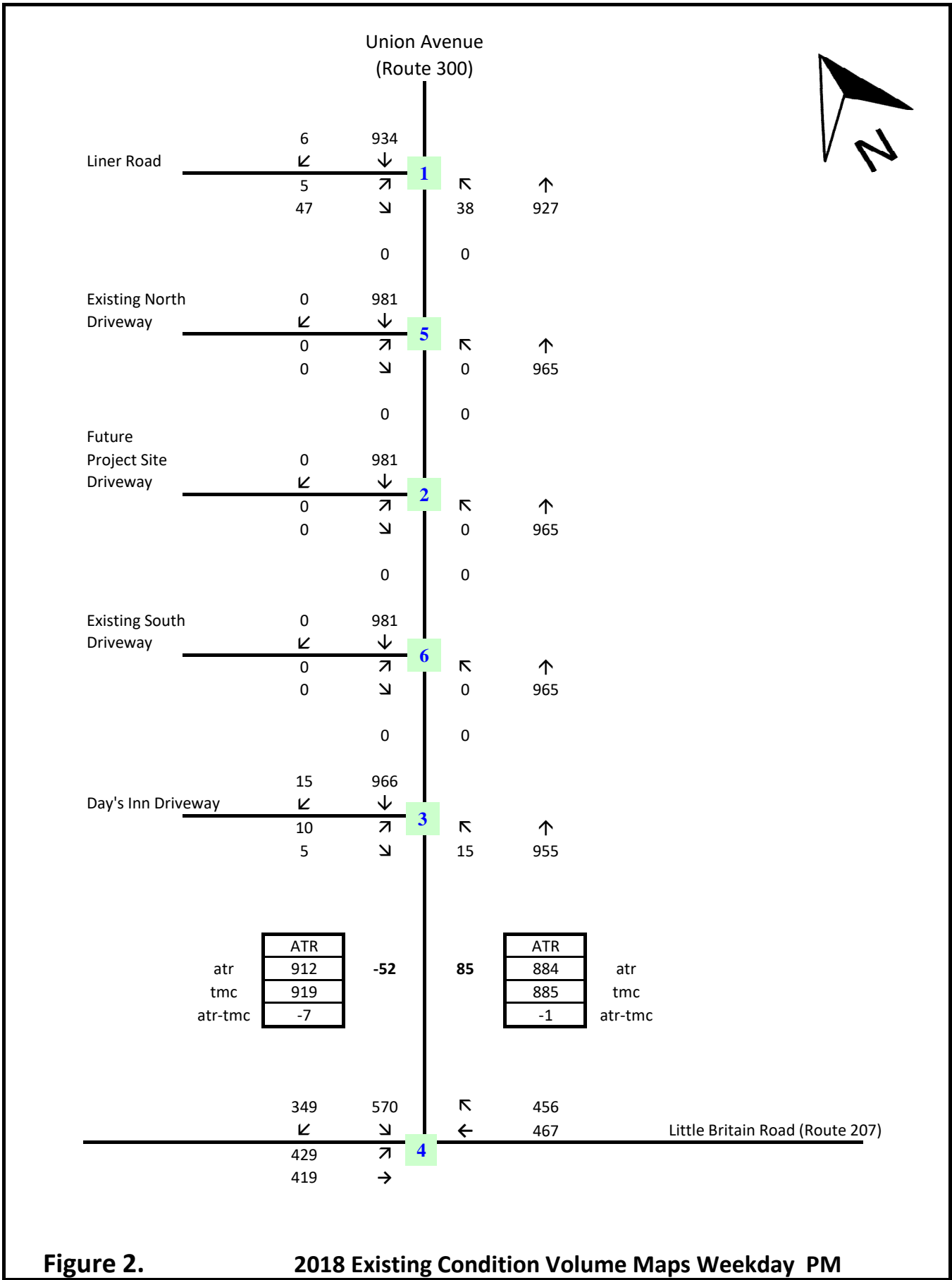
LOS F describes operation with control delay exceeding 80 seconds per vehicle or a volume-to-capacity ratio greater than 1.0. This level is typically assigned when the volume-to-capacity ratio is very high, progression is very poor, and the cycle length is long. Most cycles fail to clear the queue.

A lane group can incur a delay less than 80 seconds per vehicle when the volume-to-capacity ratio exceeds 1.0. This condition typically occurs when the cycle length is short, the signal progression is favorable, or both. As a result, both the delay and volume-to-capacity ratio are considered when lane group LOS is established. A ratio of 1.0 or more indicates that cycle capacity is fully utilized and represents failure from a capacity perspective (just as delay in excess of 80 seconds per vehicle represents failure from a delay perspective).

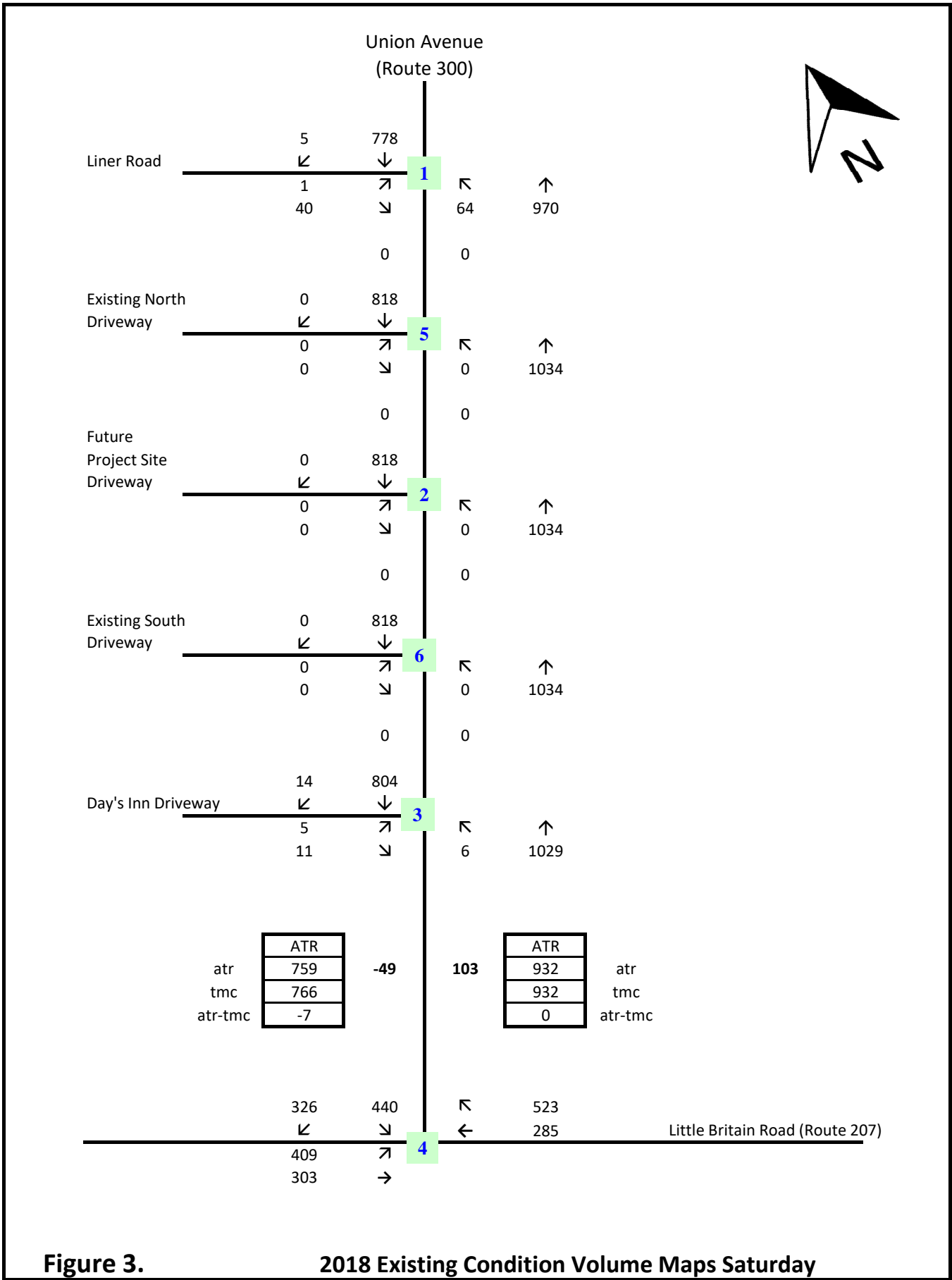
The control delay criteria for the range of service levels for signalized intersections are shown in **Table 1**.



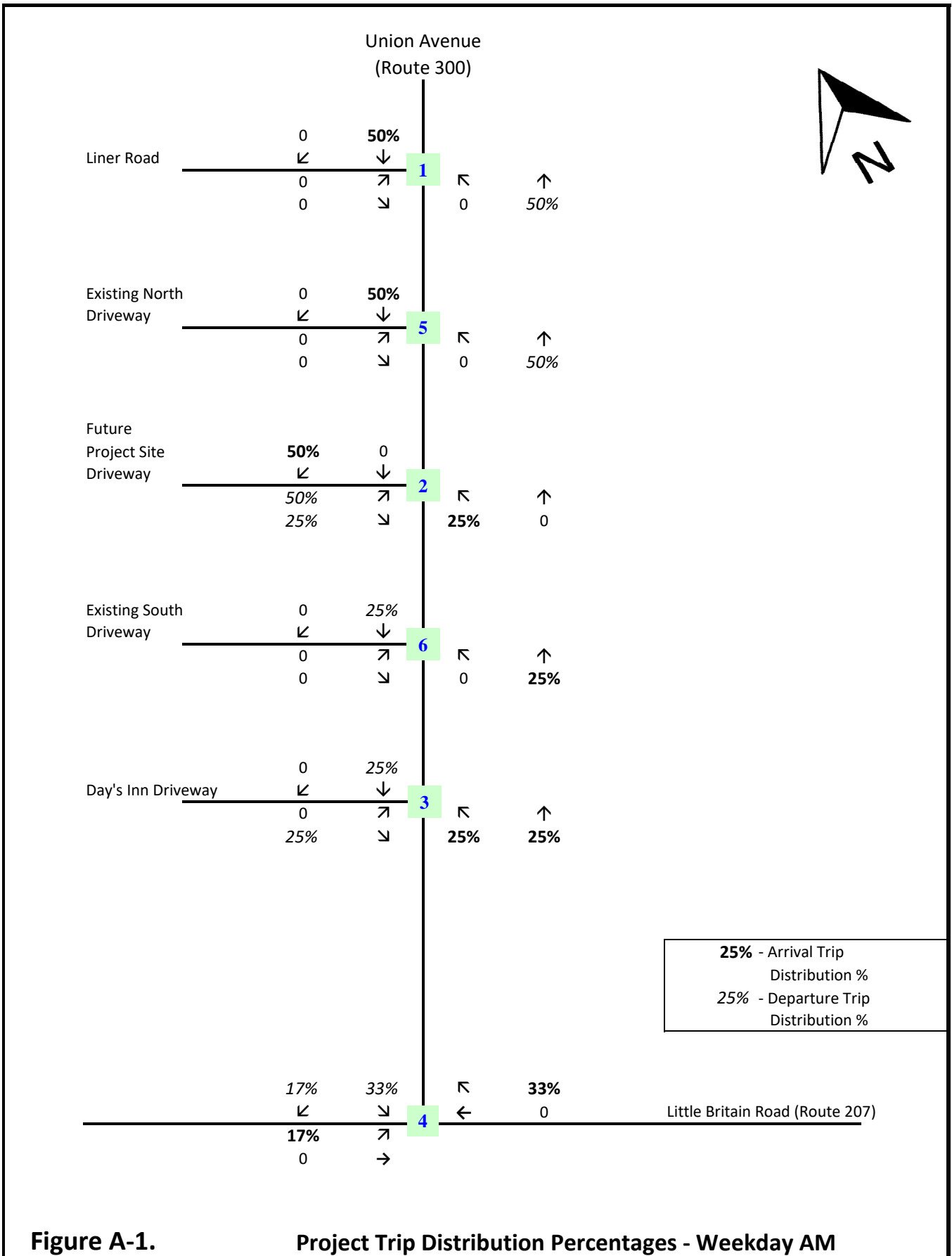
**Figure 1. 2018 Existing Condition Volume Maps Weekday AM**



**Figure 2. 2018 Existing Condition Volume Maps Weekday PM**

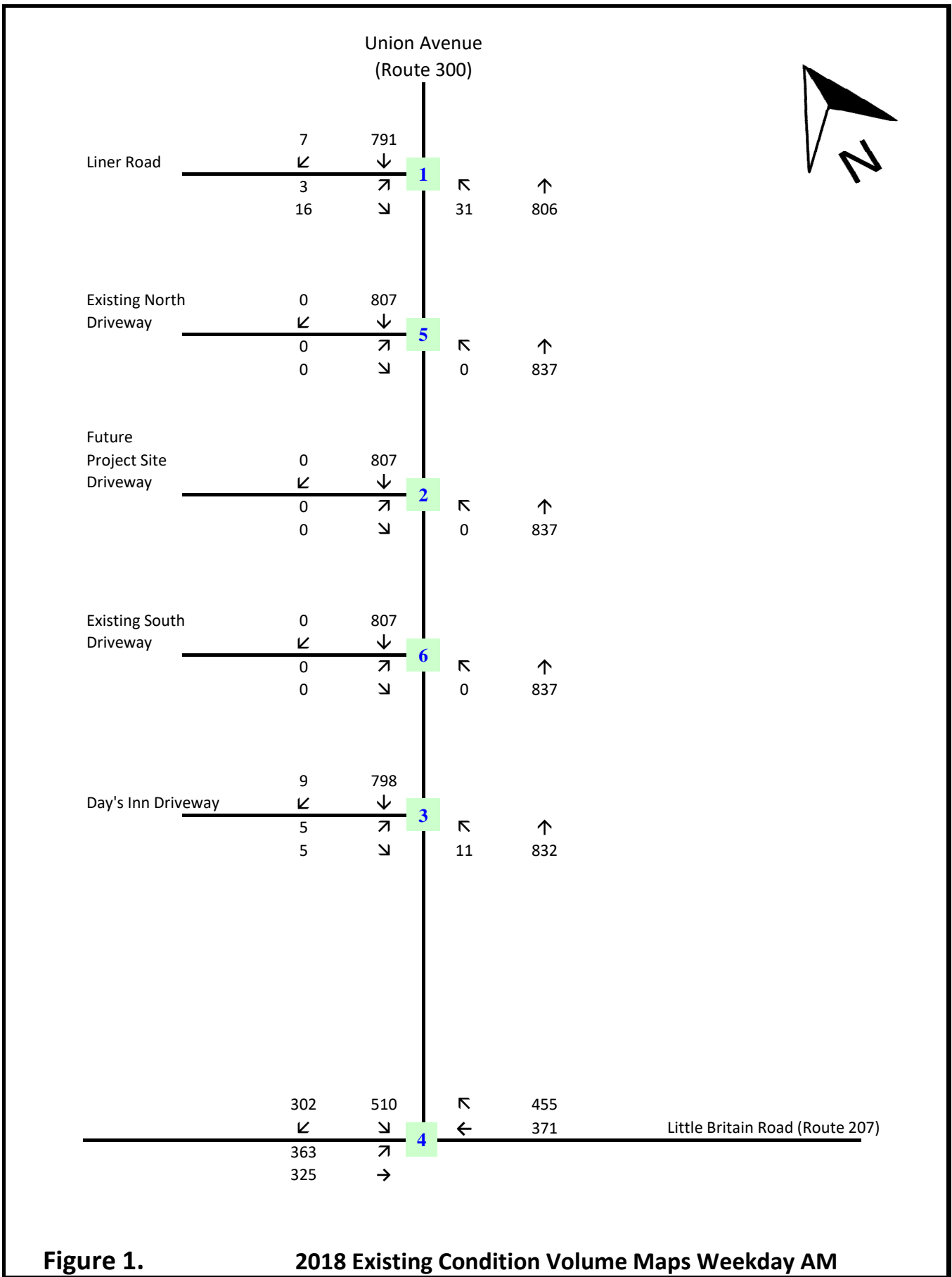






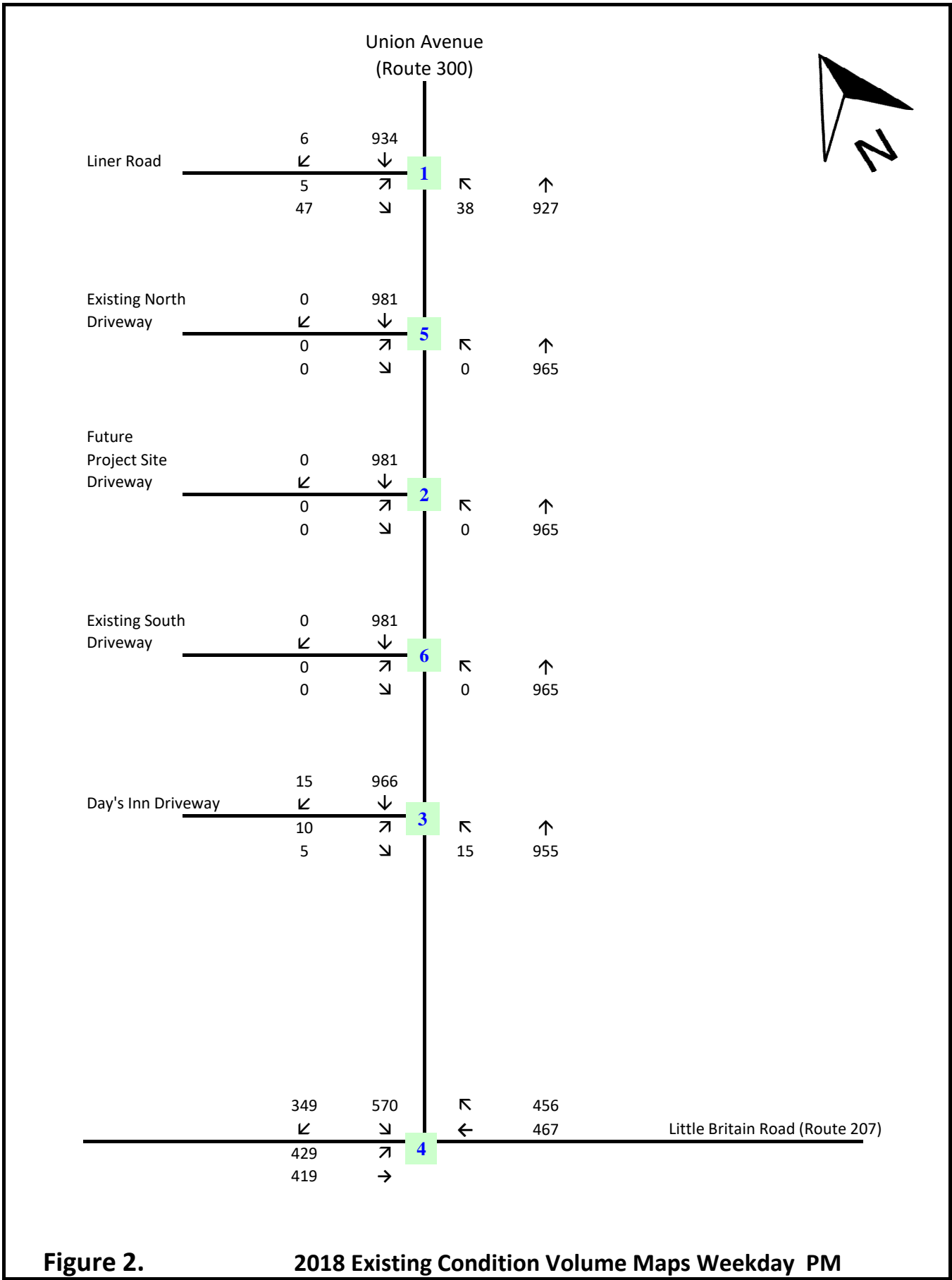






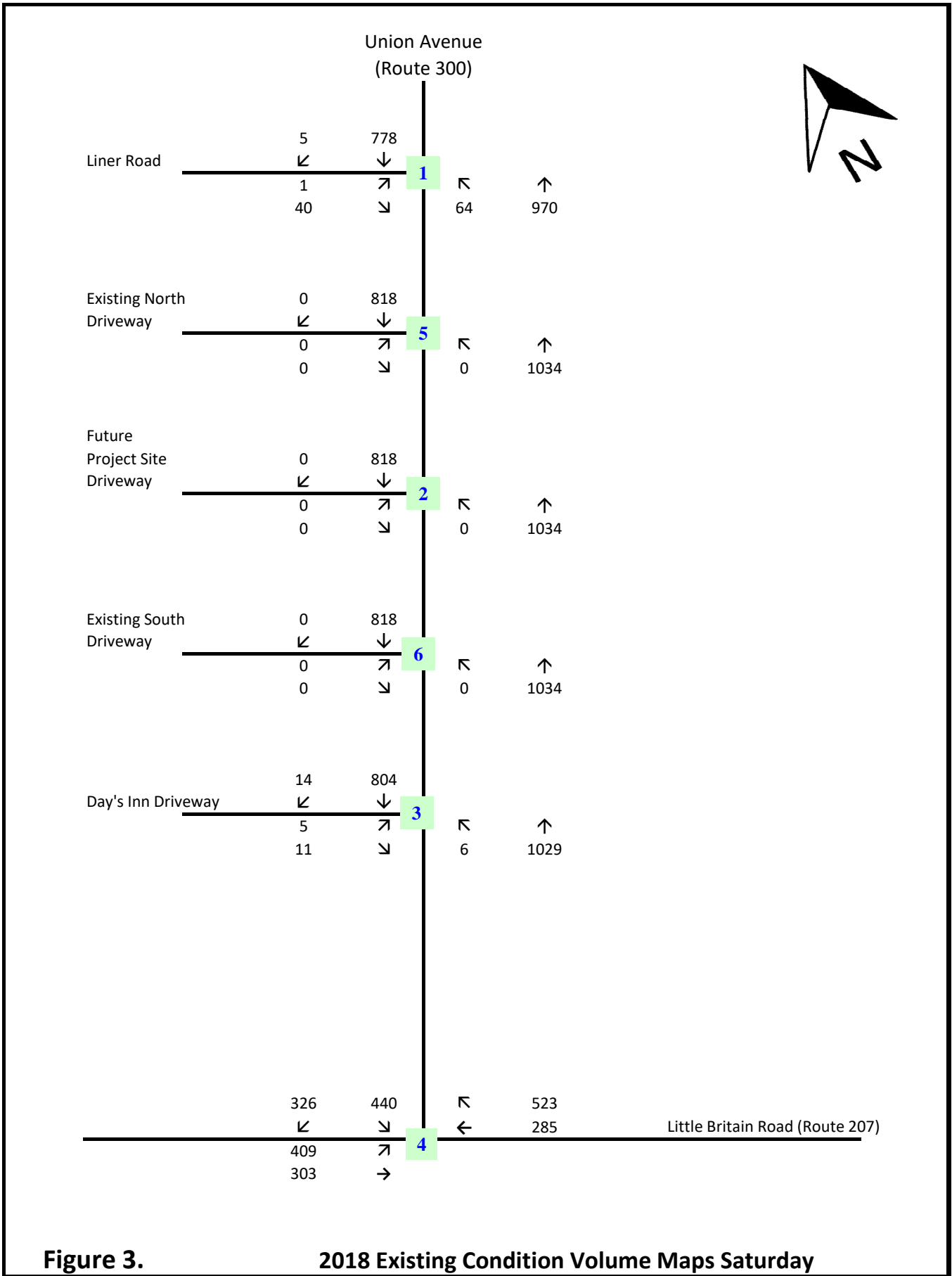
**Figure 1.**

**2018 Existing Condition Volume Maps Weekday AM**



**Figure 2.**

**2018 Existing Condition Volume Maps Weekday PM**



**Figure 3.**

**2018 Existing Condition Volume Maps Saturday**

**Table 1**  
**LOS Criteria for Signalized Intersections**

Control Delay Per Vehicle	Level-of-Service (LOS) <sup>(1)</sup>	
	v/c ratio ≤ 1.0	v/c ratio > 1.0
≤ 10.0 seconds	A	F
>10.0 and ≤ 20.0 seconds	B	F
>20.0 and ≤ 35.0 seconds	C	F
>35.0 and ≤ 55.0 seconds	D	F
>55.0 and ≤ 80.0 seconds	E	F
>80.0 seconds	F	F

**Source:** Transportation Research Board. *2010 Highway Capacity Manual*.  
**Note:** (1) For approach-based and intersection wide assessments, LOS is defined solely by control delay.

*Unsignalized Intersections*

LOS for a two-way stop-controlled (TWSC) and all-way stop-controlled (AWSC) intersections is determined by the computed or measured control delay. For motor vehicles, LOS is determined for each minor-street movement (or shared movement) as well as major-street left turns at TWSC intersections and for all movements at AWSC intersections. LOS is not defined for the intersection as a whole for TWSC and AWSC intersections.

The LOS criteria for both TWSC and AWSC unsignalized intersections are summarized in **Table 2**.

**Table 2**  
**LOS Criteria for Unsignalized Intersections**

Control Delay Per Vehicle	Level-of-Service (LOS) <sup>(1)</sup>	
	v/c ratio ≤ 1.0	v/c ratio > 1.0
≤ 10.0 seconds	A	F
>10.0 and ≤ 15.0 seconds	B	F
>15.0 and ≤ 25.0 seconds	C	F
>25.0 and ≤ 35.0 seconds	D	F
>35.0 and ≤ 50.0 seconds	E	F
>50.0 seconds	F	F

**Source:** Transportation Research Board. *2010 Highway Capacity Manual*.  
**Note:** (1) For TWSC intersections, the LOS criteria apply to each lane on a given approach and to each approach on the minor street (for TWSC intersections). LOS is not calculated for major-street approaches or for the intersection as a whole.

Note that the LOS criteria for unsignalized intersections are somewhat different from the criteria used in signalized intersections. At TWSC intersections, drivers on the stop-controlled approaches are required to select gaps in the major-street flow in order to execute crossing or turning maneuvers. In the presence of a queue, each driver on the controlled approach must also use some time to move into the front-of-queue position and prepare to evaluate gaps in the major-street flow. AWSC intersections require drivers on all approaches to stop before proceeding into the intersection.

**EXISTING OPERATING CONDITIONS**

Traffic operating conditions at each Study Area intersection were analyzed using the *HCM2010* methodology (see **Appendix A** for Synchro 10 outputs for all Study Area intersections) to compute delays, v/c ratios, and LOS as described above.

During peak hours, LOS D operations are generally considered to be acceptable operating conditions for signalized and unsignalized intersections. As shown in **Table 3** all of the study

area intersection lane groups/approaches operate at LOS D or better under 2018 Existing Conditions during the peak hours analyzed.

**Table 3**  
**2018 Existing Conditions Level of Service Analysis**

Intersection	Weekday AM				Weekday PM				Saturday				
	Lane Group	v/c Ratio	Delay (sec)	LOS	Lane Group	v/c Ratio	Delay (sec)	LOS	Lane Group	v/c Ratio	Delay (sec)	LOS	
<b>Signalized Intersections</b>													
Union Avenue and Little Britain Road													
EB	L	0.77	22.3	C	L	0.87	44.4	D	L	0.77	19.2	B	
	T	0.34	9.8	A	T	0.39	11.2	B	T	0.33	9.1	A	
WB	T	0.76	38.0	D	T	0.89	54.6	D	T	0.68	35.5	D	
	R	0.50	6.5	A	R	0.53	10.7	B	R	0.60	9.9	A	
SB	L	0.68	35.5	D	L	0.82	52.3	D	L	0.64	31.5	C	
	R	0.35	5.8	A	R	0.42	12.2	B	R	0.35	2.8	A	
Intersection			20.7	C	Intersection			32.8	C	Intersection		17.8	B
<b>Unsignalized Intersections</b>													
Union Avenue and Liner Road													
EB	L	0.02	21.2	C	L	0.03	23.0	C	L	0.01	23.3	C	
	R	0.04	11.9	B	L	0.11	12.7	B	L	0.10	11.9	B	
NB	L	0.05	10.0	A	LTR	0.06	10.5	B	LTR	0.09	10.0	B	
Union Avenue and Days Inn Driveway													
EB	LR	0.06	16.0	C	LR	0.08	19.9	C	LR	0.08	14.7	B	
NB	L	0.01	9.9	A	L	0.02	10.7	B	L	0.01	9.8	A	

**CRASH DATA**

**Table 4** summarizes the most recent three year’s traffic crash data for each of the study area intersections compiled from the NYSDOT records for the period of October 13, 2014 through September 19, 2017 (see **Appendix A** for NYSDOT crash data records). **Table 5** summarizes recent three year’s traffic crash data for each of the study area non-intersection locations (i.e., road segments between study area intersections) compiled from the same NYSDOT records.

*INTERSECTION CRASHES*

**Table 4** summarizes the most recent three year’s traffic crash data for each of the study area intersections compiled from the NYSDOT records for the period of October 13, 2014 through September 19, 2017.

During the October 13, 2014 through September 19, 2017 three-year period, a total of 34 reportable and non-reportable crashes, zero fatalities, four injuries, and zero pedestrian/bicyclist-related crashes occurred at the study area intersections. A rolling total of crash data identified one High Accident Location (HAL – defined as where five or more accidents (crashes) are reported at an intersection or along a corridor in a 12-month period) was identified in the study area at the intersection of Union Avenue and Little Britain Road. **Table 4** depicts total crash characteristics by intersection during the study period.

The most commonly occurring types of crashes at these locations were rear-end collisions. Right-angle, left-turn, overtaking and sideswipe were other types of collisions which occurred at these intersections.



The most common crash factors at the study area intersections were vehicles following too closely (“tailgating”) and failure to yield right of way, with other factors including disregard of traffic control devices, turning improper, unsafe speed, illness, passing or lane usage improperly and driver inattention.

**Table 4**  
**Study Area Crash Summary - Intersection Locations**

Intersection	Number of Crashes		Crash Trend											
	Avg/ Yr	3 Yr Total	Personal Injuries	Fatalities	Reported	Non Reported	Overtaking/ Sideswipe	Rear End	Right Angle Left Turn (with other car)	Left Turn (against other car)	Side-swipe	Ped/ Bike	Other	Unknown
Union Avenue and Liner Road	2	6	0	0	4	2	0	2	2	1	0	0	1	1
Union Avenue and Little Britain Road	9.3	28	4	0	21	7	4	13	3	0	1	0	6	0

Source: NYSDOT

*NON-INTERSECTION CRASHES*

**Table 5** summarizes the most recent three year’s traffic crash data for each roadway segment within the study area compiled from the NYSDOT records for the period of October 13, 2014 through September 19, 2017.

During the October 13, 2014 through September 19, 2017 three-year period, a total of 40 reportable and non-reportable crashes, zero fatalities, 21 injuries, and zero pedestrian/bicyclist-related crashes occurred along roadway segments in the study area. A rolling total of crash data identified two High Accident Location (HAL – defined as where five or more accidents (crashes) are reported at an intersection or along a corridor in a 12-month period) were identified in the study area- (1) along the Union Avenue corridor between Liner Road and Little Britain Road and (2) along the Union Avenue corridor between Old Little Britain Road and Liner Road. **Table 5** depicts total crash characteristics by roadway segment during the study period.

As shown in **Table 5**, the most commonly occurring types of crashes along these road segments were rear-end collisions and right angle collisions.

The most common crash factor at the study area intersections was vehicles passing or lane usage improperly while other factors included driver following too closely and driver inattention.

**Table 5**  
**Study Area Crash Summary – Non-Intersection Locations**

Road Segment	Number of Crashes		Crash Trend											
	Avg/ Yr	3 Yr Total	Personal Injuries	Fatalities	Reported	Non Reported	Overtaking/ Sideswipe	Rear End	Right Angle Left Turn (with other car)	Left Turn (against other car)	Right Turn (against other car)	Side-swipe	Head On	Other
Union Avenue Between Liner Road and Little Britain Road	8	24	14	0	20	4	2	6	6	2	1	1	1	5
Union Avenue Between Old Little Britain Road and Liner Road	5.3	16	7	0	9	7	3	5	1	1	1	0	0	4

Source: NYSDOT

## **PARKING**

Off-street parking facilities are present for the land uses in the study area, including the Days Inn hotel and Ikaros Diner. On-street parking is prohibited along the study area roadways.

## **PEDESTRIAN AND BICYCLE CONDITIONS**

Pedestrian and bicycle activity were not observed in the study area. No sidewalks exist along any of the study area roadways. In addition, pedestrian crosswalks do not exist at any of the study area intersections.

## **PUBLIC TRANSPORTATION**

No public transportation service is available in the immediate study area, however public transportation is available within the Town of New Windsor and municipalities in close proximity. The Metropolitan Transportation Authority's (MTA) Metro-North Railroad offers two commuter rail lines near the study area; (1) the Port Jervis Line via Penn Station (transfer at Secaucus) and (2) the Hudson Line via Grand Central. The Salisbury Mills/Cornwall train station is located approximately 5 miles south of the project site, within the Town of Salisbury Mills. The Beacon train station is located approximately 7.5 miles east of the study area across the Newburgh Beacon Bridge. From Beacon a ferry connects to Newburgh.

The ShortLine Bus Service serves Orange County providing local service as well as commuter service to New York City. New Windsor is a "flag" stop (stop which buses stop only on request) on both the local and commuter routes. There are two weekend buses and one weekday midday bus to New York City and two buses from New York City daily. There are three local buses on weekdays and two on weekends which operate from the Newburgh Park & Ride to West Point and Bear Mountain stopping in New Windsor along Route 9W. In addition, The Transit Orange Bus Service Broadway Route operates between Broadway and Liberty in Newburgh, NY and the Newburgh Walmart just north of Liner Road (which is the nearest stop to the study area) daily from 7AM to 7PM approximately every 30 minutes. Stewart International Airport is located adjacent to the study area approximately 2.5 miles away.

## **C. FUTURE WITHOUT THE PROPOSED PROJECT**

### **TRAFFIC CONDITIONS**

The Future without the Proposed Project, or "No Build," traffic condition is an interim scenario that establishes a future baseline condition without the Proposed Project. The No Build year is the same year as the Build year of the Proposed Project (2019). No Build traffic conditions are ascertained based on the following procedure:

- Increase the 2018 Existing Conditions traffic volumes by 1.0 percent per year from 2018 (existing year) to 2019 (build year) for background growth. The use of 1.0 percent per year was based on the 2010-2035 NYMTC Regional Transportation Plan and previous transportation studies conducted in the area.
- Manually add trips from pending developments ("No Build projects") located in the vicinity of the study area. This included the proposed Days Inn Hotel expansion, with the construction of two new hotel buildings on the site of the existing Days Inn (one five-story comprising of approximately 102 rooms and the other four-story comprising approximately 88 rooms).

Discrete trips generated by the Days Inn development were calculated utilizing trip generation rates contained in the *Institute of Transportation Engineers (ITE) Trip Generation Manual, 10th Edition*. The trips generated for this development are shown in **Table 6**.

**Table 6**  
**No Build Development Trip Generation**

Building Component	Weekday AM Peak Hour			Weekday PM Peak Hour			Saturday Peak Hour		
	In	Out	Total	In	Out	Total	In	Out	Total
Days Inn Hotel	53	37	90	59	57	116	76	59	135
<b>Source:</b> <i>Institute of Transportation Engineers (ITE) Trip Generation Manual, 10th Edition</i>									

The traffic from the No Build projects were added to the grown 2018 traffic volumes to develop the 2019 No Build volumes. Traffic volumes for the 2019 No Build Condition for the peak hours analyzed are shown in **Figures 4** through **6**.

In addition, the proposed hotel will replace the on-site Steak and Stein restaurant, which is approximately 6,000 gross square feet. Although trips from this restaurant are excluded from the No Action analysis (and are presented for comparison purposes only), it should be noted that the No Action condition would get worse if the restaurant was fully operational. Trips generated from the on-site restaurant were calculated utilizing trip generation rates contained in the *Institute of Transportation Engineers (ITE) Trip Generation Manual, 10th Edition* and are shown in **Table 7**.

**Table 7**  
**On-Site Restaurant Development Trip Generation**

Building Component	Weekday AM Peak Hour			Weekday PM Peak Hour			Saturday Peak Hour		
	In	Out	Total	In	Out	Total	In	Out	Total
Restaurant	32	26	58	35	22	57	33	32	65
<b>Source:</b> <i>Institute of Transportation Engineers (ITE) Trip Generation Manual, 10th Edition</i>									

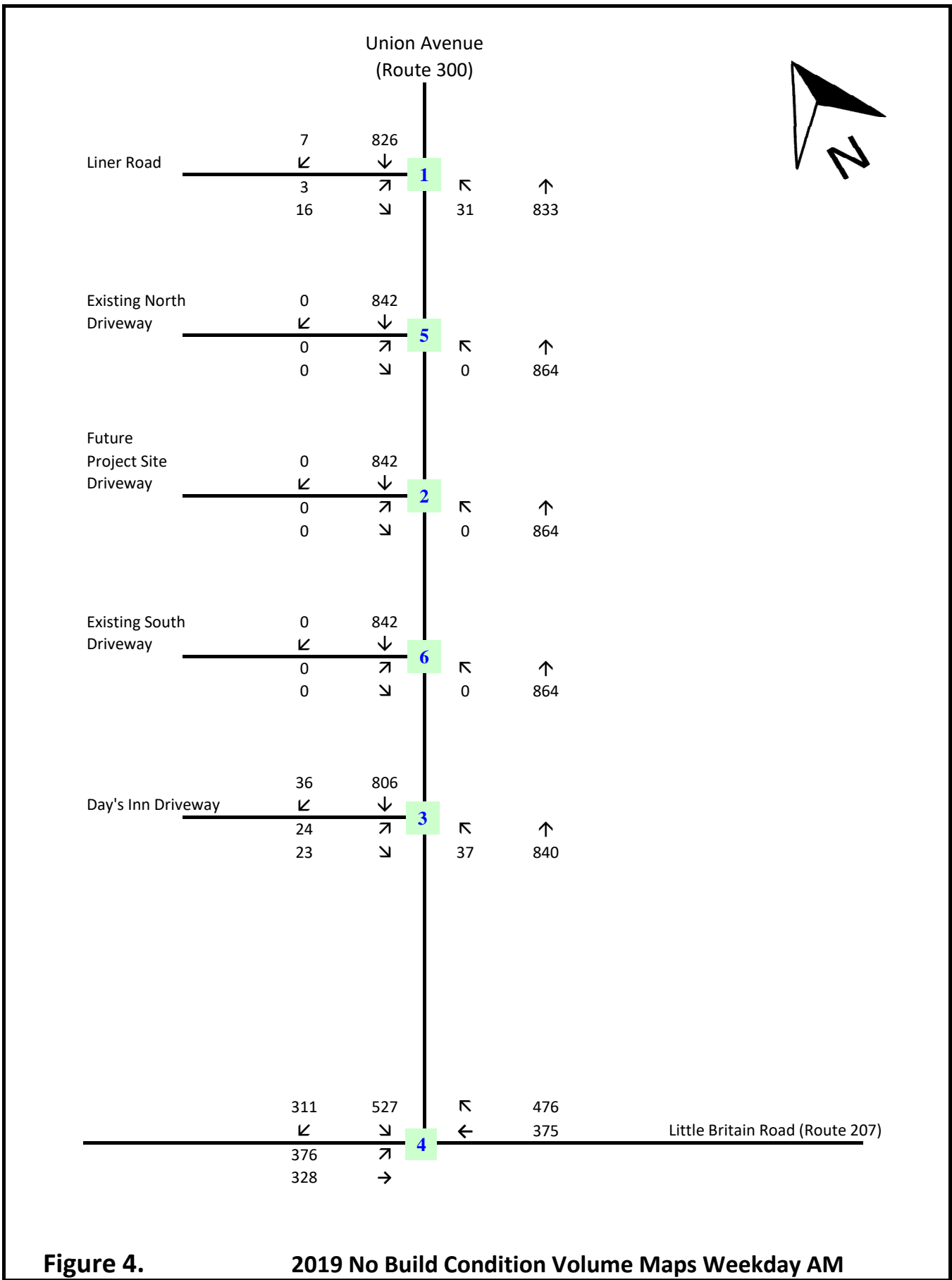
**Table 8** presents a comparison of 2018 Existing and 2019 No Build LOS conditions for the study area intersections for the peak hours. Synchro 10 outputs for the 2019 No Build scenario are provided in **Appendix A**.

**CRASH DATA**

With the increase in development in the area surrounding the project site study area and accompanying traffic volumes, there may be an increase in the number of crashes experienced under 2019 No Build Conditions.

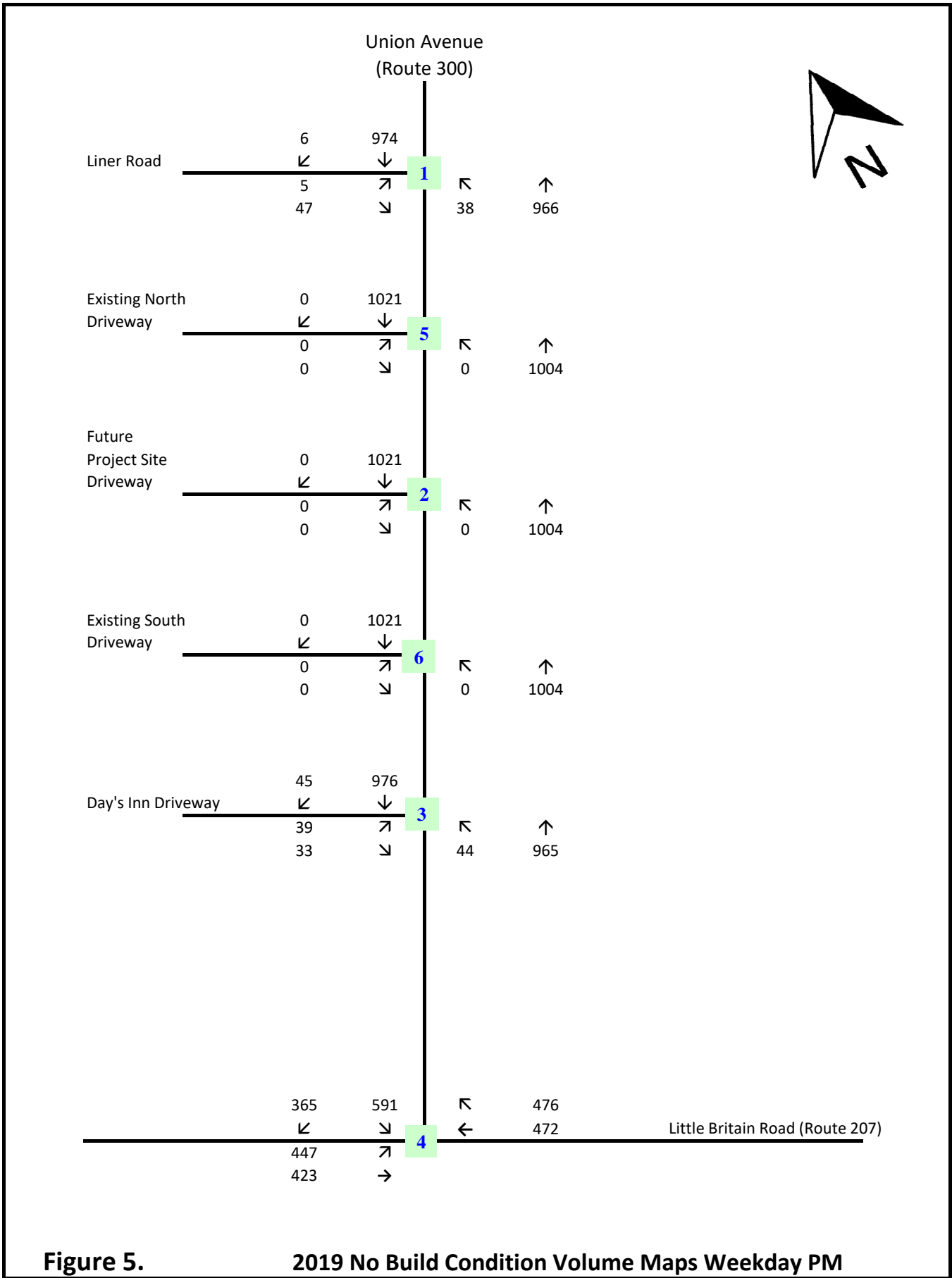
**PEDESTRIAN AND BICYCLE CONDITIONS**

No significant changes in study area pedestrian and bicycle conditions are expected under 2019 No Build Conditions.



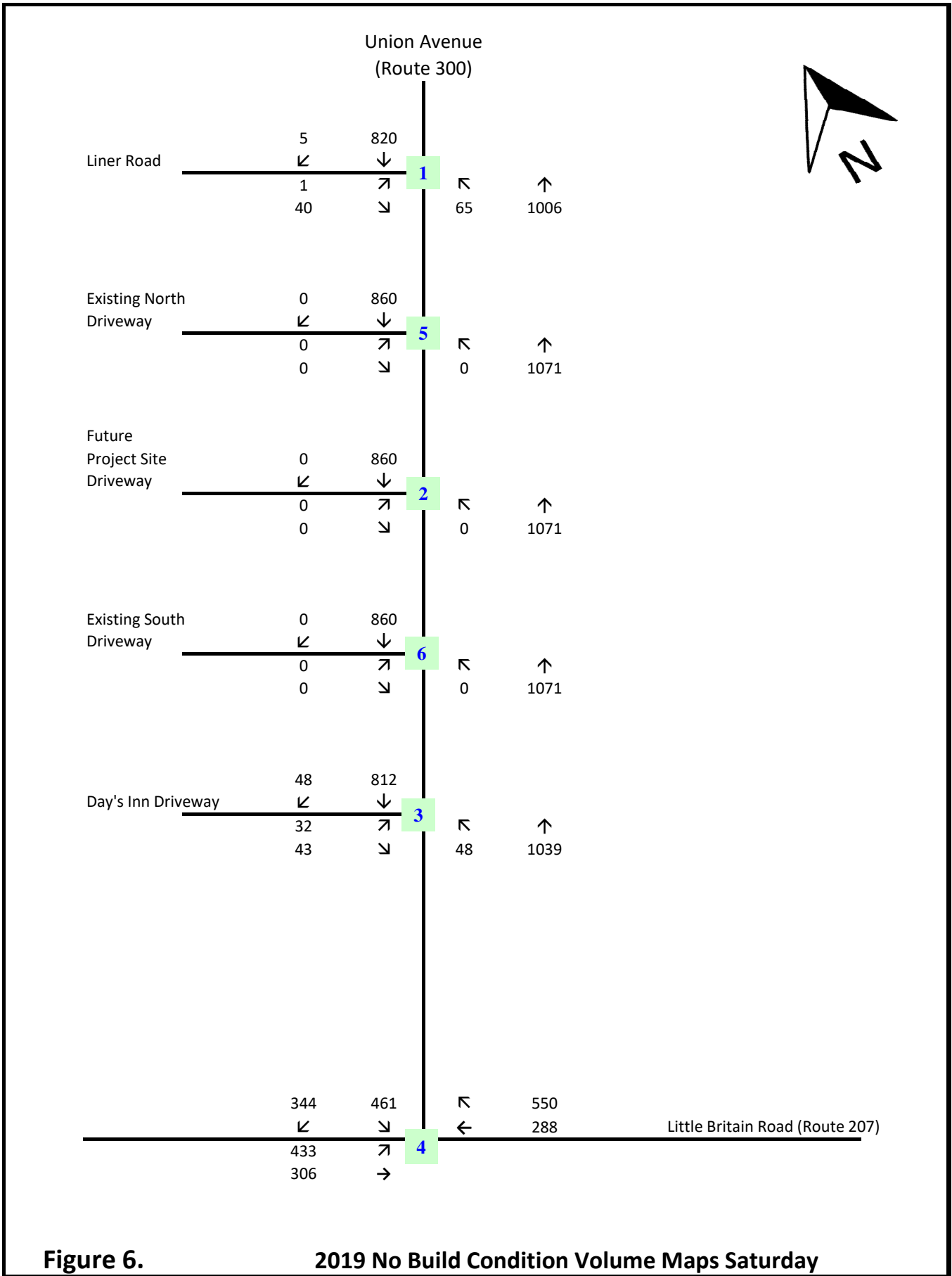
**Figure 4.**

**2019 No Build Condition Volume Maps Weekday AM**



**Figure 5.**

**2019 No Build Condition Volume Maps Weekday PM**



**Figure 6.**

**2019 No Build Condition Volume Maps Saturday**

**PUBLIC TRANSPORTATION**

No significant changes in public transportation conditions are expected under 2019 No Build Conditions.

**Table 8  
2018 Existing and 2019 No Build Conditions Level of Service Analysis**

Intersection	Weekday AM								Weekday PM								Saturday							
	2018 Existing				2019 No Build				2018 Existing				2019 No Build				2018 Existing				2019 No Build			
	Lane Group	v/c Ratio	Delay (sec)	LOS	Lane Group	v/c Ratio	Delay (sec)	LOS	Lane Group	v/c Ratio	Delay (sec)	LOS	Lane Group	v/c Ratio	Delay (sec)	LOS	Lane Group	v/c Ratio	Delay (sec)	LOS	Lane Group	v/c Ratio	Delay (sec)	LOS
<b>Signalized Intersections</b>																								
Union Avenue and Little Britain Road																								
EB	L	0.77	22.3	C	L	0.79	24.6	C	L	0.87	44.4	D	L	0.93	55.2	E	L	0.77	19.2	B	L	0.80	22.0	C
	T	0.34	9.8	A	T	0.34	10.2	B	T	0.39	11.2	B	T	0.39	11.8	B	T	0.33	9.1	A	T	0.33	9.4	A
WB	T	0.76	38.0	D	T	0.78	39.9	D	T	0.89	54.6	D	T	0.90	56.3	E	T	0.68	35.5	D	T	0.70	38.0	D
	R	0.50	6.5	A	R	0.53	7.4	A	R	0.53	10.7	B	R	0.55	11.3	B	R	0.60	9.9	A	R	0.64	12.0	B
SB	L	0.68	35.5	D	L	0.70	36.8	D	L	0.82	52.3	D	L	0.83	52.6	D	L	0.64	31.5	C	L	0.66	33.2	C
	R	0.35	5.8	A	R	0.35	6.2	A	R	0.42	12.2	B	R	0.44	12.9	B	R	0.35	2.8	A	R	0.37	3.1	A
	Intersection	20.7	C	Intersection	21.9	C	Intersection	32.8	C	Intersection	35.1	D	Intersection	17.8	0.0	Intersection	19.4	B						
<b>Unsignalized Intersections</b>																								
Union Avenue and Liner Road																								
EB	L	0.02	21.2	C	L	0.02	22.1	C	L	0.03	23.0	C	L	0.03	25.1	D	L	0.01	23.3	C	L	0.01	24.8	C
	R	0.04	11.9	B	R	0.04	12.1	B	R	0.11	12.7	B	R	0.12	13.3	B	R	0.10	11.9	B	R	0.10	12.2	B
NB	L	0.05	10.0	A	L	0.05	10.1	B	L	0.06	10.5	B	L	0.06	10.8	B	L	0.09	10.0	B	L	0.09	10.3	B
Union Avenue and Days Inn Driveway																								
EB	LR	0.06	16.0	C	LR	0.27	22.8	C	LR	0.08	19.9	C	LR	0.38	27.8	D	LR	0.08	14.7	B	LR	0.49	27.3	D
NB	L	0.02	9.9	A	L	0.06	10.3	B	L	0.02	10.7	B	L	0.07	11.2	B	L	0.01	9.8	A	L	0.07	10.3	B

**D. POTENTIAL IMPACTS OF THE PROPOSED PROJECT**

**PROJECT DESCRIPTION**

The Proposed Project, located at 935 Union Avenue (NYS Route 300), redevelops the existing site of the vacant Steak and Stein restaurant to a 93 room hotel. Access to the site is proposed to be provided by the existing site driveway just off of Union Avenue and intersecting with the existing Days Inn Hotel driveway and via a curb cut on Union Avenue. As part of the Proposed Project, the two existing curb cuts located on Union Avenue between Liner Road and Days Inn Hotel driveway would be replaced with a single curb cut located between the two existing. The Proposed Project would provide approximately 94 parking spaces.

**PROJECT TRIP GENERATION**

The projected number of trips was generated based on data from the *Institute of Transportation Engineers (ITE) Trip Generation Manual, 10th Edition*. The trips generated for the proposed development are shown in **Table 9**.

**Table 9**

**Build Development Trip Generation**

Building Component	Weekday AM Peak Hour			Weekday PM Peak Hour			Saturday Peak Hour		
	In	Out	Total	In	Out	Total	In	Out	Total
Proposed Hotel	24	17	41	22	22	44	38	30	68
Source: Based on Institute of Transportation Engineers (ITE) Trip Generation Manual, 10th Edition									

Similar to the No Build condition, the trips from the vacant existing on-site restaurant are also excluded from the Build analysis.

**PROJECT VEHICLE TRIP DISTRIBUTION AND ASSIGNMENT**

For the purpose of estimating the likely distribution of project-generated trips to and from the project site, a directional distribution of vehicle trips was created for each peak hour utilizing the existing travel patterns in the traffic network. These trip distribution patterns also represent the most logical approach and departure paths to and from the project site. **Figures 7 through 9** show the project generated vehicle trips for the peak hours analyzed.

**TRAFFIC CONDITIONS**

The project-generated traffic volumes described above were added to the No Build traffic volumes to estimate the Build traffic volumes. **Figures 10 through 12** show the 2019 Build traffic volumes for the weekday AM, weekday PM and Saturday peak hours, respectively. **Table 10** presents a comparison of the 2019 No Build and 2019 Build conditions for the study area intersections.

The addition of the project generated traffic did not result in any significant adverse impacts that would require mitigation.

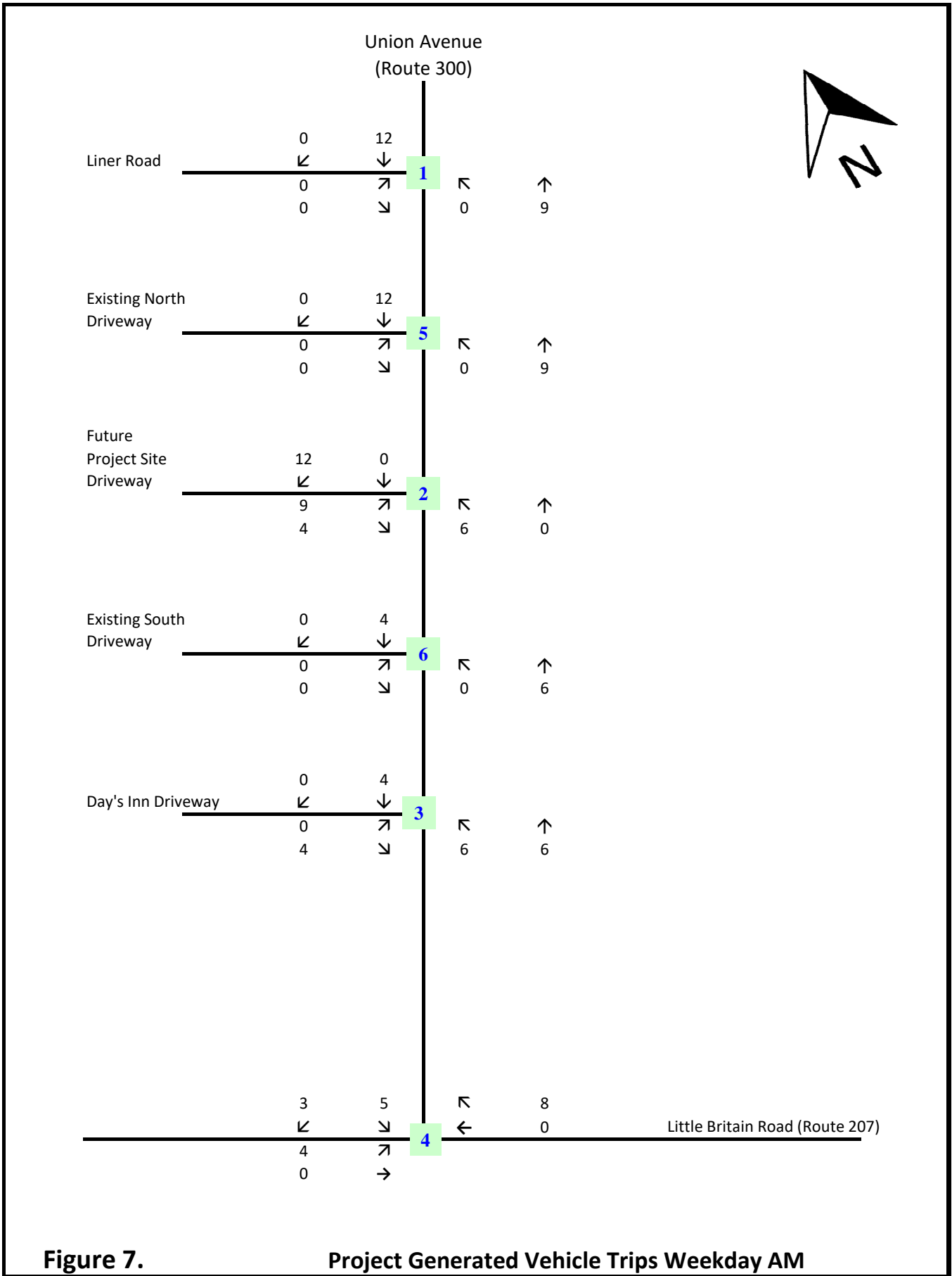
**TRAFFIC CIRCULATION**

The Proposed Project would maintain the existing driveway just off of Union Avenue and intersecting with the Days Inn driveway and would close two curb cuts along Union Avenue to be replaced with a single curb cut for access from Union Avenue. Both driveways would allow for two-way traffic via one lane in either direction. The reduction of curb cuts along Union Avenue will improve traffic circulation to and from the site and will create less vehicular conflicts and improve safety.

**PARKING**

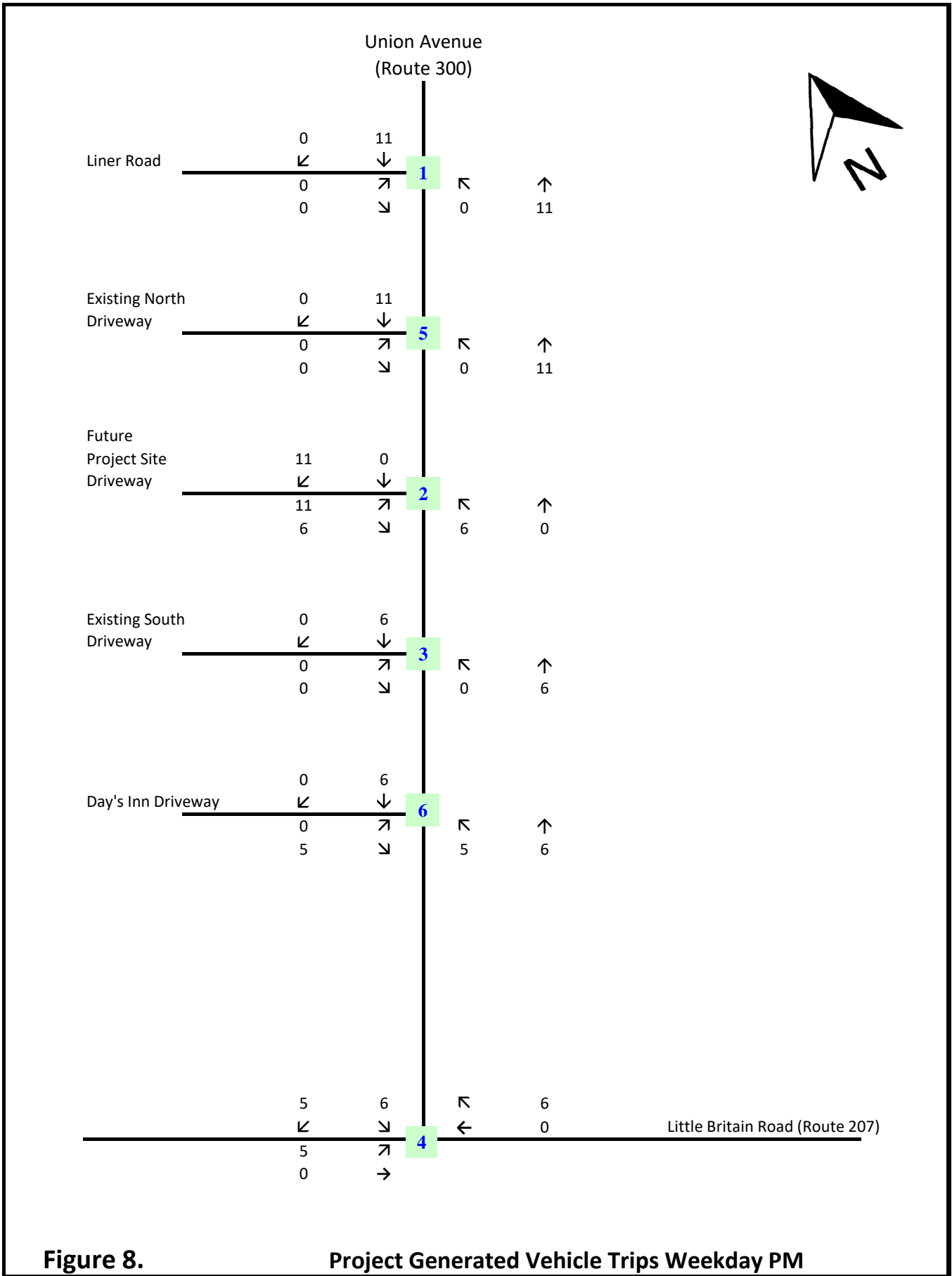
The Proposed Project would provide approximately 94 parking spaces.

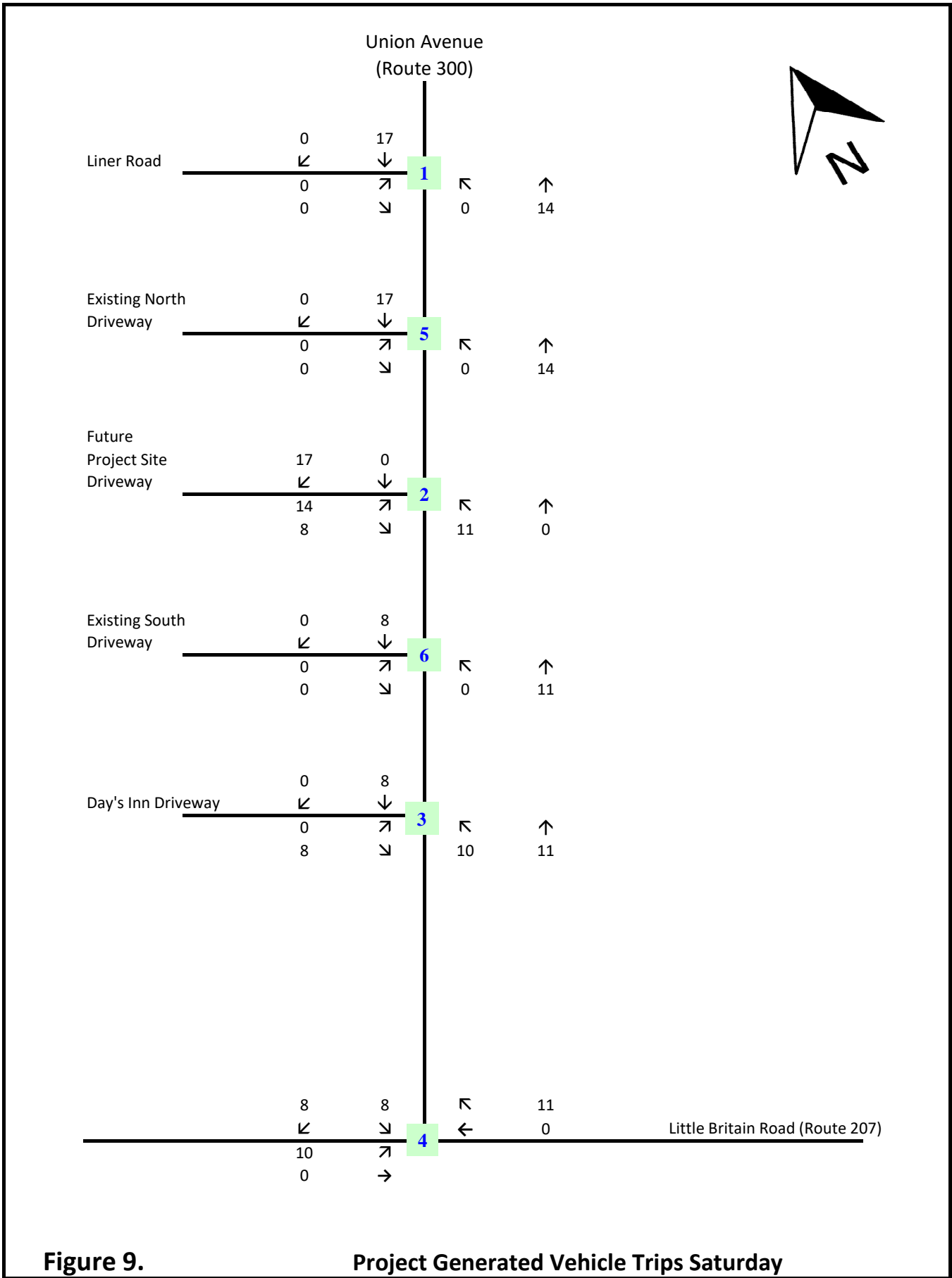




**Figure 7.**

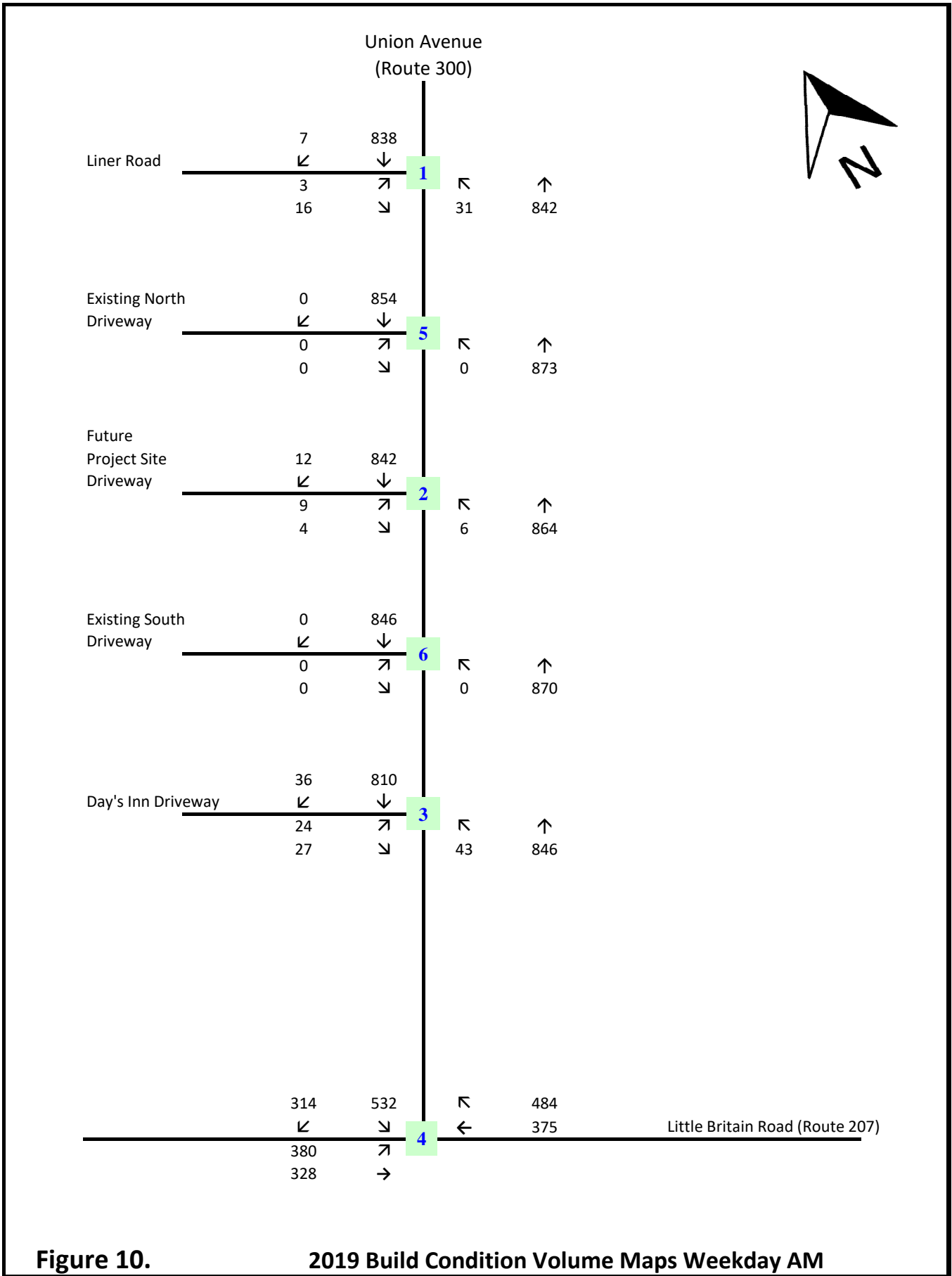
**Project Generated Vehicle Trips Weekday AM**





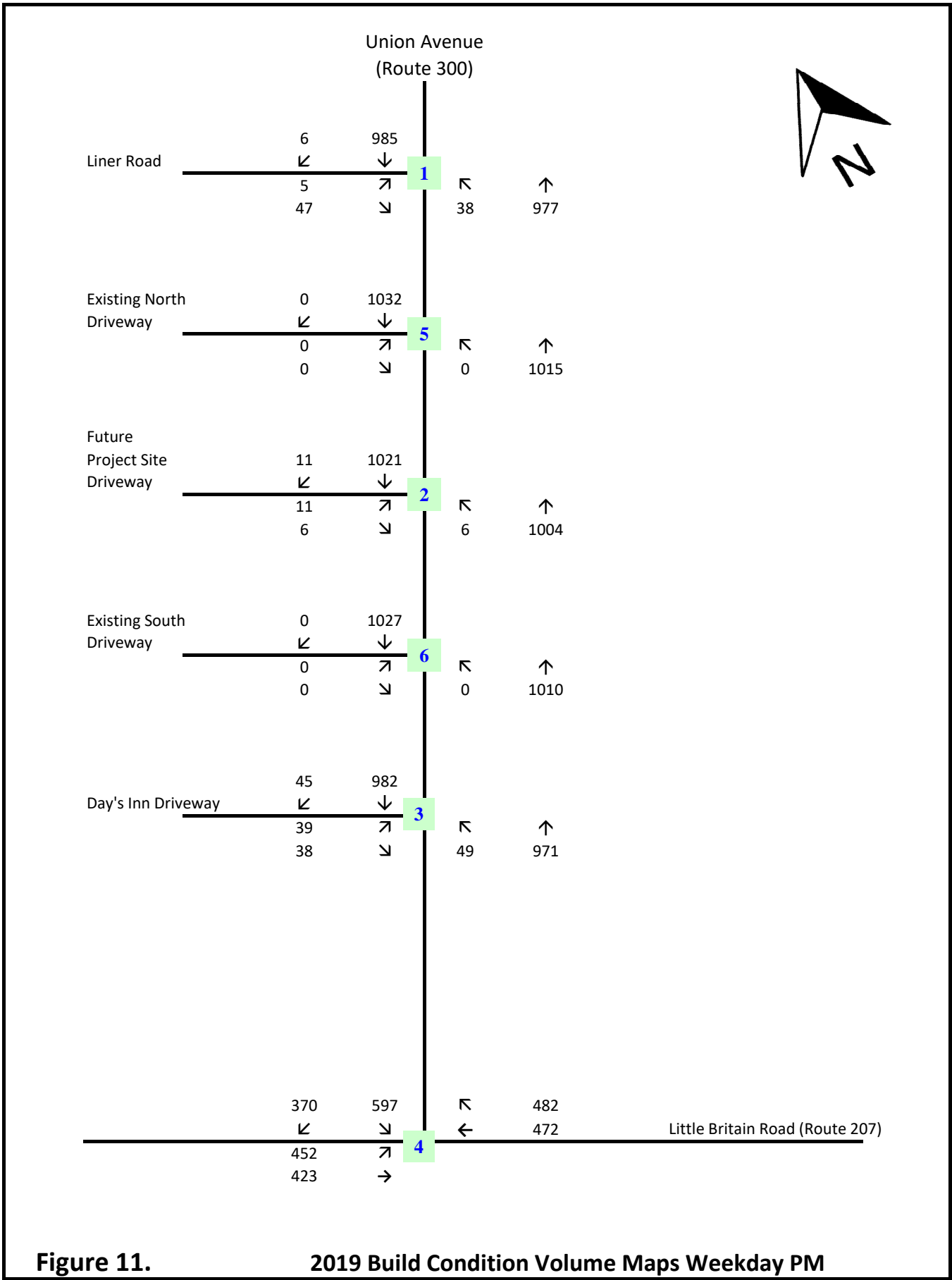
**Figure 9.**

**Project Generated Vehicle Trips Saturday**



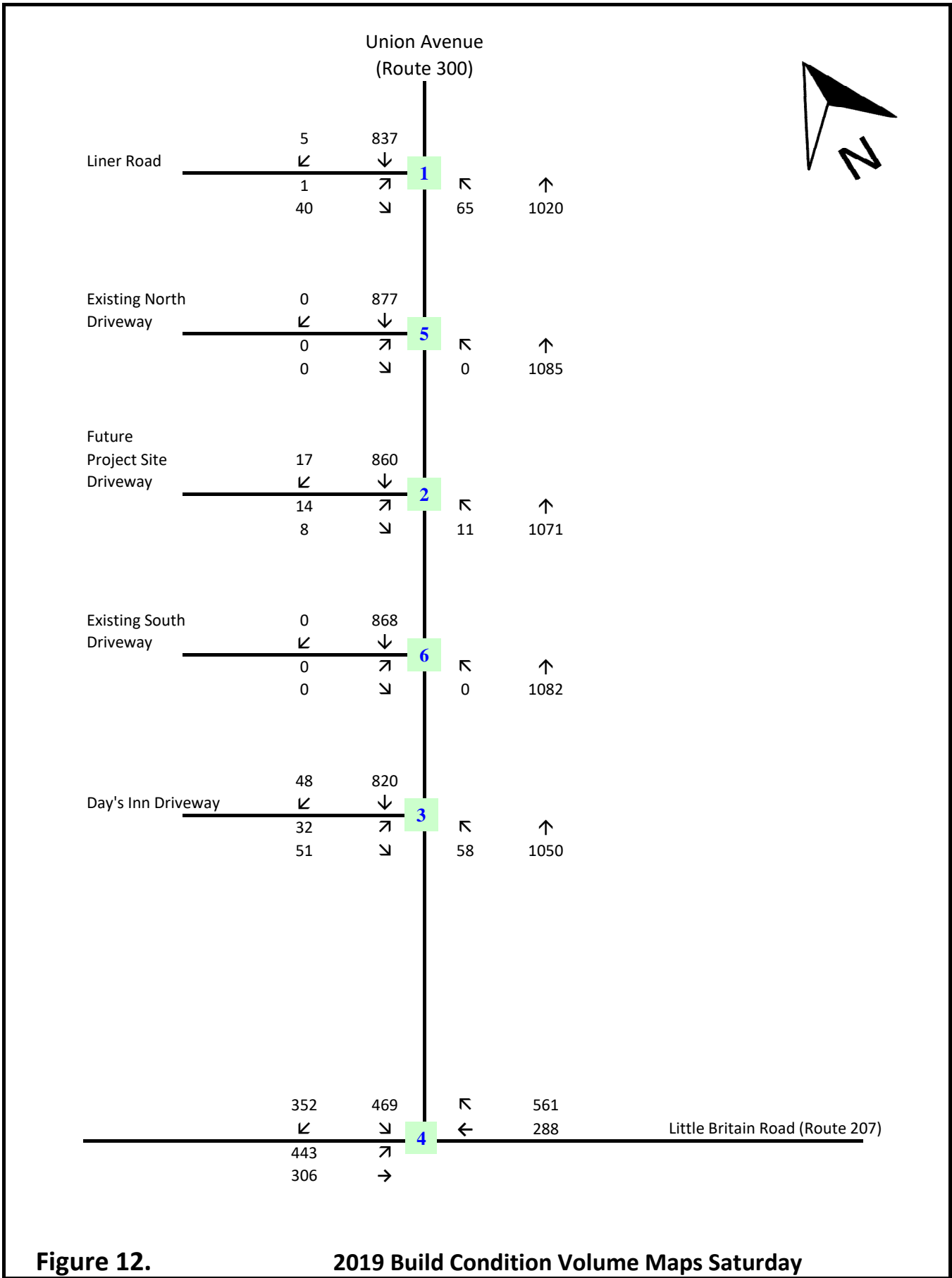
**Figure 10.**

**2019 Build Condition Volume Maps Weekday AM**



**Figure 11.**

**2019 Build Condition Volume Maps Weekday PM**



**Figure 12.**

**2019 Build Condition Volume Maps Saturday**

**Table 10**  
**2019 No Build and With Build Conditions Analysis**

Intersection	Weekday AM								Weekday PM								Weekday PM																																
	2019 No Build				2019 With Build				2019 No Build				2019 With Build				2019 No Build				2019 With Build																												
	Lane Group	v/c Ratio	Delay (sec)	LOS	Lane Group	v/c Ratio	Delay (sec)	LOS	Lane Group	v/c Ratio	Delay (sec)	LOS	Lane Group	v/c Ratio	Delay (sec)	LOS	Lane Group	v/c Ratio	Delay (sec)	LOS	Lane Group	v/c Ratio	Delay (sec)	LOS																									
<b>Signalized Intersections</b>																																																	
Union Avenue and Little Britain Road																																																	
EB	L	0.79	24.6	C	L	0.79	25.3	C	L	0.93	55.2	E	L	0.94	57.9	E	L	0.80	22.0	C	L	0.81	23.0	C	T	0.34	10.2	B	TR	0.34	10.2	B	TR	0.39	11.8	B	TR	0.39	11.9	B	TR	0.33	9.4	A	TR	0.33	9.4	A	
	WB	T	0.78	39.9	D	L	0.78	40.4	D	L	0.90	56.3	E	L	0.90	56.7	E	L	0.70	38.0	D	L	0.71	38.9	D	R	0.53	7.4	A	TR	0.54	7.8	A	TR	0.55	11.3	B	TR	0.56	11.5	B	TR	0.64	12.0	B	TR	0.66	12.9	B
SB	L	0.70	36.8	D	LT	0.70	37.2	D	LT	0.83	52.6	D	LT	0.83	52.6	D	LT	0.66	33.2	C	LT	0.68	33.8	C	R	0.35	6.2	A	R	0.36	6.3	A	R	0.44	12.9	B	R	0.45	13.0	B	R	0.37	3.1	A	R	0.38	3.3	A	
	Intersection		21.9 C		Intersection		22.2 C		Intersection		35.1 D		Intersection		35.7 D		Intersection		19.4 B		Intersection		20.0 C																										
<b>Unsignalized Intersections</b>																																																	
Union Avenue and Liner Road																																																	
EB	L	0.02	22.1	C	L	0.02	22.4	C	L	0.03	25.1	D	L	0.03	25.5	D	L	0.01	24.8	C	L	0.01	25.4	D	R	0.04	12.1	B	R	0.05	12.1	B	R	0.12	13.3	B	R	0.12	13.4	B	R	0.10	12.2	B	R	0.10	12.3	B	
	NB	L	0.05	10.1	B	L	0.05	10.2	B	L	0.06	10.8	B	L	0.06	10.8	B	L	0.09	10.3	B	L	0.09	10.4	B																								
Union Avenue and Proposed Project Site Driveway																																																	
EB				LR	0.09	18.5	C				LR	0.09	20.4	C				LR	0.16	20.0	C																												
NB				L	0.01	10.1	B				L	0.01	10.9	B				L	0.02	10.1	B																												
Union Avenue and Days Inn Driveway																																																	
EB	LR	0.27	22.8	C	LR	0.33	22.1	C	LR	0.38	27.8	D	LR	0.41	28.9	D	LR	0.49	27.3	D	LR	0.54	29.9	D	NB	L	0.06	10.3	B	L	0.07	10.4	B	L	0.07	11.2	B	L	0.08	11.3	B	L	0.07	10.3	B	L	0.09	10.4	B

**CRASH DATA**

As there would be a minimal increase in traffic volumes in the study area from the Proposed Project as compared to the No Build Condition, it is not expected that there would be a notable increase in the crash experience in the study area under 2019 Build conditions. The removal of the curb cuts along Union Avenue, which will reduce vehicular conflicts adjacent to the Proposed Project, should improve safety in the area.

**PEDESTRIAN AND BICYCLE CONDITIONS**

No significant changes in study area pedestrian and bicycle conditions are expected under 2019 Build Conditions

**PUBLIC TRANSPORTATION**

No significant changes are expected in the study area public transportation conditions under 2019 Build Conditions.

# **Attachment A**

## Revised Capacity Analysis Worksheets

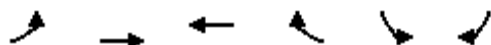


*2019 NO BUILD CONDITION  
CAPACITY ANALYSIS WORKSHEETS  
(AM, PM, and Saturday Peak Hours - Revised)*

# Lanes, Volumes, Timings

## 4: Little Britain Road & Union Avenue

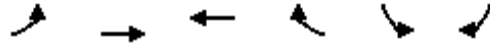
11/05/2018



Lane Group	EBL	EBT	WBT	WBR	SBL	SBR
Lane Configurations						
Traffic Volume (vph)	376	328	375	476	527	311
Future Volume (vph)	376	328	375	476	527	311
Ideal Flow (vphpl)	1900	1900	1900	1900	1900	1900
Lane Width (ft)	11	11	11	11	11	13
Storage Length (ft)	0			0	340	0
Storage Lanes	1			1	1	1
Taper Length (ft)	25				25	
Lane Util. Factor	1.00	1.00	1.00	1.00	0.97	1.00
Fr <sub>t</sub>				0.850		0.850
Fl <sub>t</sub> Protected	0.950				0.950	
Satd. Flow (prot)	1678	1766	1766	1501	3193	1574
Fl <sub>t</sub> Permitted	0.235				0.950	
Satd. Flow (perm)	415	1766	1766	1501	3193	1574
Right Turn on Red				Yes		Yes
Satd. Flow (RTOR)				192		197
Link Speed (mph)		45	45		45	
Link Distance (ft)		727	855		2865	
Travel Time (s)		11.0	13.0		43.4	
Peak Hour Factor	0.92	0.92	0.88	0.88	0.93	0.93
Heavy Vehicles (%)	4%	4%	4%	4%	6%	6%
Adj. Flow (vph)	409	357	426	541	567	334
Shared Lane Traffic (%)						
Lane Group Flow (vph)	409	357	426	541	567	334
Enter Blocked Intersection	No	No	No	No	No	No
Lane Alignment	Left	Left	Left	Right	Left	Right
Median Width(ft)		11	11		22	
Link Offset(ft)		0	0		0	
Crosswalk Width(ft)		16	16		16	
Two way Left Turn Lane					Yes	
Headway Factor	1.04	1.04	1.04	1.04	1.04	0.96
Turning Speed (mph)	15			9	15	9
Number of Detectors	1	2	2	1	1	1
Detector Template	Left	Thru	Thru	Right	Left	Right
Leading Detector (ft)	20	100	100	20	20	20
Trailing Detector (ft)	0	0	0	0	0	0
Detector 1 Position(ft)	0	0	0	0	0	0
Detector 1 Size(ft)	20	6	6	20	20	20
Detector 1 Type	Cl+Ex	Cl+Ex	Cl+Ex	Cl+Ex	Cl+Ex	Cl+Ex
Detector 1 Channel						
Detector 1 Extend (s)	0.0	0.0	0.0	0.0	0.0	0.0
Detector 1 Queue (s)	0.0	0.0	0.0	0.0	0.0	0.0
Detector 1 Delay (s)	0.0	0.0	0.0	0.0	0.0	0.0
Detector 2 Position(ft)		94	94			
Detector 2 Size(ft)		6	6			
Detector 2 Type		Cl+Ex	Cl+Ex			
Detector 2 Channel						
Detector 2 Extend (s)		0.0	0.0			
Turn Type	pm+pt	NA	NA	pm+ov	Prot	pm+ov

Lanes, Volumes, Timings  
4: Little Britain Road & Union Avenue

11/05/2018



Lane Group	EBL	EBT	WBT	WBR	SBL	SBR
Protected Phases	1	5	2	3	3	1
Permitted Phases	5			2		3
Detector Phase	1	5	2	3	3	1
Switch Phase						
Minimum Initial (s)	3.0	10.0	10.0	10.0	10.0	3.0
Minimum Split (s)	14.5	22.5	22.5	22.5	22.5	14.5
Total Split (s)	36.0	87.0	51.0	51.0	51.0	36.0
Total Split (%)	26.1%	63.0%	37.0%	37.0%	37.0%	26.1%
Maximum Green (s)	30.0	81.0	45.0	45.0	45.0	30.0
Yellow Time (s)	5.0	5.0	5.0	5.0	5.0	5.0
All-Red Time (s)	1.0	1.0	1.0	1.0	1.0	1.0
Lost Time Adjust (s)	0.0	0.0	0.0	0.0	0.0	0.0
Total Lost Time (s)	6.0	6.0	6.0	6.0	6.0	6.0
Lead/Lag	Lead		Lag			Lead
Lead-Lag Optimize?	Yes		Yes			Yes
Vehicle Extension (s)	2.0	2.0	2.0	2.0	2.0	2.0
Recall Mode	None	None	None	None	None	None
Act Effct Green (s)	53.2	53.2	27.6	56.8	22.7	48.3
Actuated g/C Ratio	0.60	0.60	0.31	0.64	0.26	0.54
v/c Ratio	0.79	0.34	0.78	0.53	0.70	0.35
Control Delay	24.6	10.2	39.9	7.4	36.8	6.2
Queue Delay	0.0	0.0	0.0	0.0	0.0	0.0
Total Delay	24.6	10.2	39.9	7.4	36.8	6.2
LOS	C	B	D	A	D	A
Approach Delay		17.9	21.7		25.5	
Approach LOS		B	C		C	

Intersection Summary

Area Type:	Other
Cycle Length:	138
Actuated Cycle Length:	88.8
Natural Cycle:	70
Control Type:	Actuated-Uncoordinated
Maximum v/c Ratio:	0.79
Intersection Signal Delay:	21.9
Intersection LOS:	C
Intersection Capacity Utilization:	70.6%
ICU Level of Service:	C
Analysis Period (min):	15

Splits and Phases: 4: Little Britain Road & Union Avenue



Intersection						
Int Delay, s/veh	0.4					
Movement	EBL	EBR	NBL	NBT	SBT	SBR
Lane Configurations						
Traffic Vol, veh/h	3	16	31	833	826	7
Future Vol, veh/h	3	16	31	833	826	7
Conflicting Peds, #/hr	0	0	0	0	0	0
Sign Control	Stop	Stop	Free	Free	Free	Free
RT Channelized	-	None	-	None	-	None
Storage Length	0	0	-	-	-	-
Veh in Median Storage, #	0	-	-	0	0	-
Grade, %	0	-	-	0	0	-
Peak Hour Factor	68	68	88	88	93	93
Heavy Vehicles, %	11	11	5	5	5	5
Mvmt Flow	4	24	35	947	888	8

Major/Minor	Minor2	Major1	Major2			
Conflicting Flow All	1436	448	896	0	-	0
Stage 1	892	-	-	-	-	-
Stage 2	544	-	-	-	-	-
Critical Hdwy	7.02	7.12	4.2	-	-	-
Critical Hdwy Stg 1	6.02	-	-	-	-	-
Critical Hdwy Stg 2	6.02	-	-	-	-	-
Follow-up Hdwy	3.61	3.41	2.25	-	-	-
Pot Cap-1 Maneuver	114	534	735	-	-	-
Stage 1	340	-	-	-	-	-
Stage 2	521	-	-	-	-	-
Platoon blocked, %				-	-	-
Mov Cap-1 Maneuver	103	534	735	-	-	-
Mov Cap-2 Maneuver	215	-	-	-	-	-
Stage 1	306	-	-	-	-	-
Stage 2	521	-	-	-	-	-

Approach	EB	NB	SB
HCM Control Delay, s	13.7	0.4	0
HCM LOS	B		

Minor Lane/Major Mvmt	NBL	NBT	EBLn1	EBLn2	SBT	SBR
Capacity (veh/h)	735	-	215	534	-	-
HCM Lane V/C Ratio	0.048	-	0.021	0.044	-	-
HCM Control Delay (s)	10.1	-	22.1	12.1	-	-
HCM Lane LOS	B	-	C	B	-	-
HCM 95th %tile Q(veh)	0.2	-	0.1	0.1	-	-

Intersection						
Int Delay, s/veh	1					
Movement	EBL	EBR	NBL	NBT	SBT	SBR
Lane Configurations	T			↑↑		↑↑
Traffic Vol, veh/h	24	13	37	840	806	36
Future Vol, veh/h	24	13	37	840	806	36
Conflicting Peds, #/hr	0	0	0	0	0	0
Sign Control	Stop	Stop	Free	Free	Free	Free
RT Channelized	-	None	-	None	-	None
Storage Length	0	-	-	-	-	-
Veh in Median Storage, #	0	-	-	0	0	-
Grade, %	0	-	-	0	0	-
Peak Hour Factor	50	50	88	88	91	91
Heavy Vehicles, %	2	2	5	5	5	5
Mvmt Flow	48	26	42	955	886	40

Major/Minor	Minor2	Major1	Major2			
Conflicting Flow All	1468	463	926	0	-	0
Stage 1	906	-	-	-	-	-
Stage 2	562	-	-	-	-	-
Critical Hdwy	6.84	6.94	4.2	-	-	-
Critical Hdwy Stg 1	5.84	-	-	-	-	-
Critical Hdwy Stg 2	5.84	-	-	-	-	-
Follow-up Hdwy	3.52	3.32	2.25	-	-	-
Pot Cap-1 Maneuver	118	546	715	-	-	-
Stage 1	355	-	-	-	-	-
Stage 2	534	-	-	-	-	-
Platoon blocked, %				-	-	-
Mov Cap-1 Maneuver	103	546	715	-	-	-
Mov Cap-2 Maneuver	218	-	-	-	-	-
Stage 1	311	-	-	-	-	-
Stage 2	534	-	-	-	-	-

Approach	EB	NB	SB
HCM Control Delay, s	22.8	0.4	0
HCM LOS	C		

Minor Lane/Major Mvmt	NBL	NBT	EBLn1	SBT	SBR
Capacity (veh/h)	715	-	276	-	-
HCM Lane V/C Ratio	0.059	-	0.268	-	-
HCM Control Delay (s)	10.3	-	22.8	-	-
HCM Lane LOS	B	-	C	-	-
HCM 95th %tile Q(veh)	0.2	-	1.1	-	-

Intersection						
Int Delay, s/veh	0					
Movement	EBL	EBR	NBL	NBT	SBT	SBR
Lane Configurations	Y			↑↑	↑↑	
Traffic Vol, veh/h	0	0	0	864	842	0
Future Vol, veh/h	0	0	0	864	842	0
Conflicting Peds, #/hr	0	0	0	0	0	0
Sign Control	Stop	Stop	Free	Free	Free	Free
RT Channelized	-	None	-	None	-	None
Storage Length	0	-	-	-	-	-
Veh in Median Storage, #	0	-	-	0	0	-
Grade, %	0	-	-	0	0	-
Peak Hour Factor	50	50	88	88	93	93
Heavy Vehicles, %	2	2	5	5	5	5
Mvmt Flow	0	0	0	982	905	0

Major/Minor	Minor2	Major1	Major2			
Conflicting Flow All	1396	453	-	0	-	0
Stage 1	905	-	-	-	-	-
Stage 2	491	-	-	-	-	-
Critical Hdwy	6.84	6.94	-	-	-	-
Critical Hdwy Stg 1	5.84	-	-	-	-	-
Critical Hdwy Stg 2	5.84	-	-	-	-	-
Follow-up Hdwy	3.52	3.32	-	-	-	-
Pot Cap-1 Maneuver	132	554	0	-	-	0
Stage 1	355	-	0	-	-	0
Stage 2	581	-	0	-	-	0
Platoon blocked, %				-	-	
Mov Cap-1 Maneuver	132	554	-	-	-	-
Mov Cap-2 Maneuver	257	-	-	-	-	-
Stage 1	355	-	-	-	-	-
Stage 2	581	-	-	-	-	-

Approach	EB	NB	SB
HCM Control Delay, s	0	0	0
HCM LOS	A		

Minor Lane/Major Mvmt	NBT	EBLn1	SBT
Capacity (veh/h)	-	-	-
HCM Lane V/C Ratio	-	-	-
HCM Control Delay (s)	-	0	-
HCM Lane LOS	-	A	-
HCM 95th %tile Q(veh)	-	-	-

Intersection						
Int Delay, s/veh	0					
Movement	EBL	EBR	NBL	NBT	SBT	SBR
Lane Configurations	T			T		
Traffic Vol, veh/h	0	0	0	864	842	0
Future Vol, veh/h	0	0	0	864	842	0
Conflicting Peds, #/hr	0	0	0	0	0	0
Sign Control	Stop	Stop	Free	Free	Free	Free
RT Channelized	-	None	-	None	-	None
Storage Length	0	-	-	-	-	-
Veh in Median Storage, #	0	-	-	0	0	-
Grade, %	0	-	-	0	0	-
Peak Hour Factor	50	50	88	88	91	91
Heavy Vehicles, %	2	2	5	5	5	5
Mvmt Flow	0	0	0	982	925	0

Major/Minor	Minor2	Major1	Major2		
Conflicting Flow All	1416	463	-	0	-
Stage 1	925	-	-	-	-
Stage 2	491	-	-	-	-
Critical Hdwy	6.84	6.94	-	-	-
Critical Hdwy Stg 1	5.84	-	-	-	-
Critical Hdwy Stg 2	5.84	-	-	-	-
Follow-up Hdwy	3.52	3.32	-	-	-
Pot Cap-1 Maneuver	128	546	0	-	-
Stage 1	347	-	0	-	-
Stage 2	581	-	0	-	-
Platoon blocked, %				-	-
Mov Cap-1 Maneuver	128	546	-	-	-
Mov Cap-2 Maneuver	252	-	-	-	-
Stage 1	347	-	-	-	-
Stage 2	581	-	-	-	-

Approach	EB	NB	SB
HCM Control Delay, s	0	0	0
HCM LOS	A		

Minor Lane/Major Mvmt	NBT	EBLn1	SBT	SBR
Capacity (veh/h)	-	-	-	-
HCM Lane V/C Ratio	-	-	-	-
HCM Control Delay (s)	-	0	-	-
HCM Lane LOS	-	A	-	-
HCM 95th %tile Q(veh)	-	-	-	-

# Lanes, Volumes, Timings

## 4: Little Britain Road & Union Avenue

11/05/2018

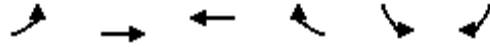


Lane Group	EBL	EBT	WBT	WBR	SBL	SBR
Lane Configurations						
Traffic Volume (vph)	447	423	472	476	591	365
Future Volume (vph)	447	423	472	476	591	365
Ideal Flow (vphpl)	1900	1900	1900	1900	1900	1900
Lane Width (ft)	11	11	11	11	11	13
Storage Length (ft)	0			0	340	0
Storage Lanes	1			1	1	1
Taper Length (ft)	25				25	
Lane Util. Factor	1.00	1.00	1.00	1.00	0.97	1.00
Fr <sub>t</sub>				0.850		0.850
Fl <sub>t</sub> Protected	0.950				0.950	
Satd. Flow (prot)	1728	1818	1766	1501	3224	1589
Fl <sub>t</sub> Permitted	0.128				0.950	
Satd. Flow (perm)	233	1818	1766	1501	3224	1589
Right Turn on Red				Yes		Yes
Satd. Flow (RTOR)				95		117
Link Speed (mph)		45	45		45	
Link Distance (ft)		727	855		2865	
Travel Time (s)		11.0	13.0		43.4	
Peak Hour Factor	0.91	0.91	0.86	0.86	0.89	0.89
Heavy Vehicles (%)	1%	1%	4%	4%	5%	5%
Adj. Flow (vph)	491	465	549	553	664	410
Shared Lane Traffic (%)						
Lane Group Flow (vph)	491	465	549	553	664	410
Enter Blocked Intersection	No	No	No	No	No	No
Lane Alignment	Left	Left	Left	Right	Left	Right
Median Width(ft)		11	11		22	
Link Offset(ft)		0	0		0	
Crosswalk Width(ft)		16	16		16	
Two way Left Turn Lane					Yes	
Headway Factor	1.04	1.04	1.04	1.04	1.04	0.96
Turning Speed (mph)	15			9	15	9
Number of Detectors	1	2	2	1	1	1
Detector Template	Left	Thru	Thru	Right	Left	Right
Leading Detector (ft)	20	100	100	20	20	20
Trailing Detector (ft)	0	0	0	0	0	0
Detector 1 Position(ft)	0	0	0	0	0	0
Detector 1 Size(ft)	20	6	6	20	20	20
Detector 1 Type	Cl+Ex	Cl+Ex	Cl+Ex	Cl+Ex	Cl+Ex	Cl+Ex
Detector 1 Channel						
Detector 1 Extend (s)	0.0	0.0	0.0	0.0	0.0	0.0
Detector 1 Queue (s)	0.0	0.0	0.0	0.0	0.0	0.0
Detector 1 Delay (s)	0.0	0.0	0.0	0.0	0.0	0.0
Detector 2 Position(ft)		94	94			
Detector 2 Size(ft)		6	6			
Detector 2 Type		Cl+Ex	Cl+Ex			
Detector 2 Channel						
Detector 2 Extend (s)		0.0	0.0			
Turn Type	pm+pt	NA	NA	pm+ov	Prot	pm+ov



Lanes, Volumes, Timings  
4: Little Britain Road & Union Avenue

11/05/2018



Lane Group	EBL	EBT	WBT	WBR	SBL	SBR
Protected Phases	1	5	2	3	3	1
Permitted Phases	5			2		3
Detector Phase	1	5	2	3	3	1
Switch Phase						
Minimum Initial (s)	3.0	10.0	10.0	10.0	10.0	3.0
Minimum Split (s)	14.5	22.5	22.5	22.5	22.5	14.5
Total Split (s)	36.0	87.0	51.0	51.0	51.0	36.0
Total Split (%)	26.1%	63.0%	37.0%	37.0%	37.0%	26.1%
Maximum Green (s)	30.0	81.0	45.0	45.0	45.0	30.0
Yellow Time (s)	5.0	5.0	5.0	5.0	5.0	5.0
All-Red Time (s)	1.0	1.0	1.0	1.0	1.0	1.0
Lost Time Adjust (s)	0.0	0.0	0.0	0.0	0.0	0.0
Total Lost Time (s)	6.0	6.0	6.0	6.0	6.0	6.0
Lead/Lag	Lead		Lag			Lead
Lead-Lag Optimize?	Yes		Yes			Yes
Vehicle Extension (s)	2.0	2.0	2.0	2.0	2.0	2.0
Recall Mode	None	None	None	None	None	None
Act Effct Green (s)	77.9	77.9	41.6	77.4	29.8	66.1
Actuated g/C Ratio	0.65	0.65	0.35	0.65	0.25	0.55
v/c Ratio	0.93	0.39	0.90	0.55	0.83	0.44
Control Delay	55.2	11.8	56.3	11.3	52.6	12.9
Queue Delay	0.0	0.0	0.0	0.0	0.0	0.0
Total Delay	55.2	11.8	56.3	11.3	52.6	12.9
LOS	E	B	E	B	D	B
Approach Delay		34.1	33.7		37.4	
Approach LOS		C	C		D	

Intersection Summary

Area Type:	Other
Cycle Length:	138
Actuated Cycle Length:	119.8
Natural Cycle:	90
Control Type:	Actuated-Uncoordinated
Maximum v/c Ratio:	0.93
Intersection Signal Delay:	35.1
Intersection LOS:	D
Intersection Capacity Utilization:	81.5%
ICU Level of Service:	D
Analysis Period (min):	15

Splits and Phases: 4: Little Britain Road & Union Avenue



Intersection						
Int Delay, s/veh	0.6					
Movement	EBL	EBR	NBL	NBT	SBT	SBR
Lane Configurations	↙	↗		↑↑	↑↑	
Traffic Vol, veh/h	5	47	38	966	974	6
Future Vol, veh/h	5	47	38	966	974	6
Conflicting Peds, #/hr	0	0	0	0	0	0
Sign Control	Stop	Stop	Free	Free	Free	Free
RT Channelized	-	None	-	None	-	None
Storage Length	0	0	-	-	-	-
Veh in Median Storage, #	0	-	-	0	0	-
Grade, %	0	-	-	0	0	-
Peak Hour Factor	81	81	98	98	96	96
Heavy Vehicles, %	8	8	4	4	5	5
Mvmt Flow	6	58	39	986	1015	6

Major/Minor	Minor2	Major1	Major2			
Conflicting Flow All	1589	511	1021	0	-	0
Stage 1	1018	-	-	-	-	-
Stage 2	571	-	-	-	-	-
Critical Hdwy	6.96	7.06	4.18	-	-	-
Critical Hdwy Stg 1	5.96	-	-	-	-	-
Critical Hdwy Stg 2	5.96	-	-	-	-	-
Follow-up Hdwy	3.58	3.38	2.24	-	-	-
Pot Cap-1 Maneuver	93	492	664	-	-	-
Stage 1	296	-	-	-	-	-
Stage 2	512	-	-	-	-	-
Platoon blocked, %				-	-	-
Mov Cap-1 Maneuver	81	492	664	-	-	-
Mov Cap-2 Maneuver	185	-	-	-	-	-
Stage 1	258	-	-	-	-	-
Stage 2	512	-	-	-	-	-

Approach	EB	NB	SB
HCM Control Delay, s	14.4	0.4	0
HCM LOS	B		

Minor Lane/Major Mvmt	NBL	NBT	EBLn1	EBLn2	SBT	SBR
Capacity (veh/h)	664	-	185	492	-	-
HCM Lane V/C Ratio	0.058	-	0.033	0.118	-	-
HCM Control Delay (s)	10.8	-	25.1	13.3	-	-
HCM Lane LOS	B	-	D	B	-	-
HCM 95th %tile Q(veh)	0.2	-	0.1	0.4	-	-

HCM 2010 TWSC  
 3: Union Avenue & Hotel Driveway

11/05/2018

Intersection						
Int Delay, s/veh	1.4					
Movement	EBL	EBR	NBL	NBT	SBT	SBR
Lane Configurations	T			↑↑		↑↑
Traffic Vol, veh/h	39	33	44	965	976	45
Future Vol, veh/h	39	33	44	965	976	45
Conflicting Peds, #/hr	0	0	0	0	0	0
Sign Control	Stop	Stop	Free	Free	Free	Free
RT Channelized	-	None	-	None	-	None
Storage Length	0	-	-	-	-	-
Veh in Median Storage, #	0	-	-	0	0	-
Grade, %	0	-	-	0	0	-
Peak Hour Factor	75	75	97	97	94	94
Heavy Vehicles, %	2	2	4	4	5	5
Mvmt Flow	52	44	45	995	1038	48

Major/Minor	Minor2	Major1	Major2			
Conflicting Flow All	1650	543	1086	0	-	0
Stage 1	1062	-	-	-	-	-
Stage 2	588	-	-	-	-	-
Critical Hdwy	6.84	6.94	4.18	-	-	-
Critical Hdwy Stg 1	5.84	-	-	-	-	-
Critical Hdwy Stg 2	5.84	-	-	-	-	-
Follow-up Hdwy	3.52	3.32	2.24	-	-	-
Pot Cap-1 Maneuver	90	484	627	-	-	-
Stage 1	294	-	-	-	-	-
Stage 2	518	-	-	-	-	-
Platoon blocked, %				-	-	-
Mov Cap-1 Maneuver	76	484	627	-	-	-
Mov Cap-2 Maneuver	179	-	-	-	-	-
Stage 1	247	-	-	-	-	-
Stage 2	518	-	-	-	-	-

Approach	EB	NB	SB
HCM Control Delay, s	27.8	0.5	0
HCM LOS	D		

Minor Lane/Major Mvmt	NBL	NBT	EBLn1	SBT	SBR
Capacity (veh/h)	627	-	252	-	-
HCM Lane V/C Ratio	0.072	-	0.381	-	-
HCM Control Delay (s)	11.2	-	27.8	-	-
HCM Lane LOS	B	-	D	-	-
HCM 95th %tile Q(veh)	0.2	-	1.7	-	-

Intersection						
Int Delay, s/veh	0					
Movement	EBL	EBR	NBL	NBT	SBT	SBR
Lane Configurations	T			T		
Traffic Vol, veh/h	0	0	0	1004	1021	0
Future Vol, veh/h	0	0	0	1004	1021	0
Conflicting Peds, #/hr	0	0	0	0	0	0
Sign Control	Stop	Stop	Free	Free	Free	Free
RT Channelized	-	None	-	None	-	None
Storage Length	0	-	-	-	-	-
Veh in Median Storage, #	0	-	-	0	0	-
Grade, %	0	-	-	0	0	-
Peak Hour Factor	75	75	98	98	96	96
Heavy Vehicles, %	2	2	4	4	5	5
Mvmt Flow	0	0	0	1024	1064	0

Major/Minor	Minor2	Major1	Major2			
Conflicting Flow All	1576	532	-	0	-	0
Stage 1	1064	-	-	-	-	-
Stage 2	512	-	-	-	-	-
Critical Hdwy	6.84	6.94	-	-	-	-
Critical Hdwy Stg 1	5.84	-	-	-	-	-
Critical Hdwy Stg 2	5.84	-	-	-	-	-
Follow-up Hdwy	3.52	3.32	-	-	-	-
Pot Cap-1 Maneuver	100	492	0	-	-	0
Stage 1	293	-	0	-	-	0
Stage 2	567	-	0	-	-	0
Platoon blocked, %				-	-	
Mov Cap-1 Maneuver	100	492	-	-	-	-
Mov Cap-2 Maneuver	216	-	-	-	-	-
Stage 1	293	-	-	-	-	-
Stage 2	567	-	-	-	-	-

Approach	EB	NB	SB
HCM Control Delay, s	0	0	0
HCM LOS	A		

Minor Lane/Major Mvmt	NBT	EBLn1	SBT
Capacity (veh/h)	-	-	-
HCM Lane V/C Ratio	-	-	-
HCM Control Delay (s)	-	0	-
HCM Lane LOS	-	A	-
HCM 95th %tile Q(veh)	-	-	-

Intersection						
Int Delay, s/veh	0					
Movement	EBL	EBR	NBL	NBT	SBT	SBR
Lane Configurations	T			T		
Traffic Vol, veh/h	0	0	0	1004	1021	0
Future Vol, veh/h	0	0	0	1004	1021	0
Conflicting Peds, #/hr	0	0	0	0	0	0
Sign Control	Stop	Stop	Free	Free	Free	Free
RT Channelized	-	None	-	None	-	None
Storage Length	0	-	-	-	-	-
Veh in Median Storage, #	0	-	-	0	0	-
Grade, %	0	-	-	0	0	-
Peak Hour Factor	75	75	97	97	94	94
Heavy Vehicles, %	2	2	4	4	5	5
Mvmt Flow	0	0	0	1035	1086	0

Major/Minor	Minor2	Major1	Major2			
Conflicting Flow All	1604	543	-	0	-	0
Stage 1	1086	-	-	-	-	-
Stage 2	518	-	-	-	-	-
Critical Hdwy	6.84	6.94	-	-	-	-
Critical Hdwy Stg 1	5.84	-	-	-	-	-
Critical Hdwy Stg 2	5.84	-	-	-	-	-
Follow-up Hdwy	3.52	3.32	-	-	-	-
Pot Cap-1 Maneuver	96	484	0	-	-	-
Stage 1	285	-	0	-	-	-
Stage 2	563	-	0	-	-	-
Platoon blocked, %				-	-	-
Mov Cap-1 Maneuver	96	484	-	-	-	-
Mov Cap-2 Maneuver	211	-	-	-	-	-
Stage 1	285	-	-	-	-	-
Stage 2	563	-	-	-	-	-

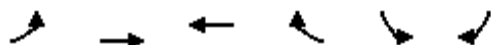
Approach	EB	NB	SB
HCM Control Delay, s	0	0	0
HCM LOS	A		

Minor Lane/Major Mvmt	NBT	EBLn1	SBT	SBR
Capacity (veh/h)	-	-	-	-
HCM Lane V/C Ratio	-	-	-	-
HCM Control Delay (s)	-	0	-	-
HCM Lane LOS	-	A	-	-
HCM 95th %tile Q(veh)	-	-	-	-

# Lanes, Volumes, Timings

## 4: Little Britain Road & Union Avenue

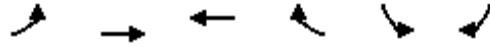
11/05/2018



Lane Group	EBL	EBT	WBT	WBR	SBL	SBR
Lane Configurations						
Traffic Volume (vph)	433	306	288	550	461	344
Future Volume (vph)	433	306	288	550	461	344
Ideal Flow (vphpl)	1900	1900	1900	1900	1900	1900
Lane Width (ft)	11	11	11	11	11	13
Storage Length (ft)	0			0	340	0
Storage Lanes	1			1	1	1
Taper Length (ft)	25				25	
Lane Util. Factor	1.00	1.00	1.00	1.00	0.97	1.00
Fr <sub>t</sub>				0.850		0.850
Fl <sub>t</sub> Protected	0.950				0.950	
Satd. Flow (prot)	1678	1766	1766	1501	3255	1605
Fl <sub>t</sub> Permitted	0.304				0.950	
Satd. Flow (perm)	537	1766	1766	1501	3255	1605
Right Turn on Red				Yes		Yes
Satd. Flow (RTOR)				155		314
Link Speed (mph)		45	45		45	
Link Distance (ft)		727	855		2865	
Travel Time (s)		11.0	13.0		43.4	
Peak Hour Factor	0.87	0.87	0.92	0.92	0.87	0.87
Heavy Vehicles (%)	4%	4%	4%	4%	4%	4%
Adj. Flow (vph)	498	352	313	598	530	395
Shared Lane Traffic (%)						
Lane Group Flow (vph)	498	352	313	598	530	395
Enter Blocked Intersection	No	No	No	No	No	No
Lane Alignment	Left	Left	Left	Right	Left	Right
Median Width(ft)		11	11		22	
Link Offset(ft)		0	0		0	
Crosswalk Width(ft)		16	16		16	
Two way Left Turn Lane					Yes	
Headway Factor	1.04	1.04	1.04	1.04	1.04	0.96
Turning Speed (mph)	15			9	15	9
Number of Detectors	1	2	2	1	1	1
Detector Template	Left	Thru	Thru	Right	Left	Right
Leading Detector (ft)	20	100	100	20	20	20
Trailing Detector (ft)	0	0	0	0	0	0
Detector 1 Position(ft)	0	0	0	0	0	0
Detector 1 Size(ft)	20	6	6	20	20	20
Detector 1 Type	Cl+Ex	Cl+Ex	Cl+Ex	Cl+Ex	Cl+Ex	Cl+Ex
Detector 1 Channel						
Detector 1 Extend (s)	0.0	0.0	0.0	0.0	0.0	0.0
Detector 1 Queue (s)	0.0	0.0	0.0	0.0	0.0	0.0
Detector 1 Delay (s)	0.0	0.0	0.0	0.0	0.0	0.0
Detector 2 Position(ft)		94	94			
Detector 2 Size(ft)		6	6			
Detector 2 Type		Cl+Ex	Cl+Ex			
Detector 2 Channel						
Detector 2 Extend (s)		0.0	0.0			
Turn Type	pm+pt	NA	NA	pm+ov	Prot	pm+ov

Lanes, Volumes, Timings  
4: Little Britain Road & Union Avenue

11/05/2018

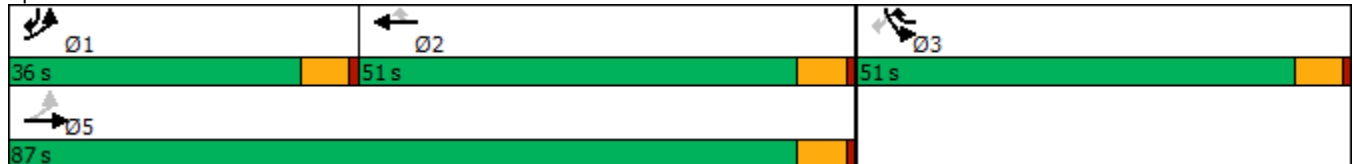


Lane Group	EBL	EBT	WBT	WBR	SBL	SBR
Protected Phases	1	5	2	3	3	1
Permitted Phases	5			2		3
Detector Phase	1	5	2	3	3	1
Switch Phase						
Minimum Initial (s)	3.0	10.0	10.0	10.0	10.0	3.0
Minimum Split (s)	14.5	22.5	22.5	22.5	22.5	14.5
Total Split (s)	36.0	87.0	51.0	51.0	51.0	36.0
Total Split (%)	26.1%	63.0%	37.0%	37.0%	37.0%	26.1%
Maximum Green (s)	30.0	81.0	45.0	45.0	45.0	30.0
Yellow Time (s)	5.0	5.0	5.0	5.0	5.0	5.0
All-Red Time (s)	1.0	1.0	1.0	1.0	1.0	1.0
Lost Time Adjust (s)	0.0	0.0	0.0	0.0	0.0	0.0
Total Lost Time (s)	6.0	6.0	6.0	6.0	6.0	6.0
Lead/Lag	Lead		Lag			Lead
Lead-Lag Optimize?	Yes		Yes			Yes
Vehicle Extension (s)	2.0	2.0	2.0	2.0	2.0	2.0
Recall Mode	None	None	None	None	None	None
Act Effct Green (s)	47.8	47.8	20.2	46.2	19.6	47.1
Actuated g/C Ratio	0.60	0.60	0.25	0.58	0.24	0.59
v/c Ratio	0.80	0.33	0.70	0.64	0.66	0.37
Control Delay	22.0	9.4	38.0	12.0	33.2	3.1
Queue Delay	0.0	0.0	0.0	0.0	0.0	0.0
Total Delay	22.0	9.4	38.0	12.0	33.2	3.1
LOS	C	A	D	B	C	A
Approach Delay		16.8	21.0		20.4	
Approach LOS		B	C		C	

Intersection Summary

Area Type:	Other
Cycle Length:	138
Actuated Cycle Length:	80
Natural Cycle:	70
Control Type:	Actuated-Uncoordinated
Maximum v/c Ratio:	0.80
Intersection Signal Delay:	19.4
Intersection LOS:	B
Intersection Capacity Utilization:	68.0%
ICU Level of Service:	C
Analysis Period (min):	15

Splits and Phases: 4: Little Britain Road & Union Avenue



Intersection						
Int Delay, s/veh	0.7					
Movement	EBL	EBR	NBL	NBT	SBT	SBR
Lane Configurations	↙	↗		↑↑	↑↑	
Traffic Vol, veh/h	1	40	65	1006	820	5
Future Vol, veh/h	1	40	65	1006	820	5
Conflicting Peds, #/hr	0	0	0	0	0	0
Sign Control	Stop	Stop	Free	Free	Free	Free
RT Channelized	-	None	-	None	-	None
Storage Length	0	0	-	-	-	-
Veh in Median Storage, #	0	-	-	0	0	-
Grade, %	0	-	-	0	0	-
Peak Hour Factor	73	73	94	94	93	93
Heavy Vehicles, %	4	4	3	3	4	4
Mvmt Flow	1	55	69	1070	882	5

Major/Minor	Minor2	Major1	Major2			
Conflicting Flow All	1558	444	887	0	-	0
Stage 1	885	-	-	-	-	-
Stage 2	673	-	-	-	-	-
Critical Hdwy	6.88	6.98	4.16	-	-	-
Critical Hdwy Stg 1	5.88	-	-	-	-	-
Critical Hdwy Stg 2	5.88	-	-	-	-	-
Follow-up Hdwy	3.54	3.34	2.23	-	-	-
Pot Cap-1 Maneuver	101	556	753	-	-	-
Stage 1	359	-	-	-	-	-
Stage 2	463	-	-	-	-	-
Platoon blocked, %				-	-	-
Mov Cap-1 Maneuver	78	556	753	-	-	-
Mov Cap-2 Maneuver	183	-	-	-	-	-
Stage 1	278	-	-	-	-	-
Stage 2	463	-	-	-	-	-

Approach	EB	NB	SB
HCM Control Delay, s	12.5	0.6	0
HCM LOS	B		

Minor Lane/Major Mvmt	NBL	NBT	EBLn1	EBLn2	SBT	SBR
Capacity (veh/h)	753	-	183	556	-	-
HCM Lane V/C Ratio	0.092	-	0.007	0.099	-	-
HCM Control Delay (s)	10.3	-	24.8	12.2	-	-
HCM Lane LOS	B	-	C	B	-	-
HCM 95th %tile Q(veh)	0.3	-	0	0.3	-	-



Intersection						
Int Delay, s/veh	2.1					
Movement	EBL	EBR	NBL	NBT	SBT	SBR
Lane Configurations	T			↑↑		↑↑
Traffic Vol, veh/h	32	43	48	1039	812	48
Future Vol, veh/h	32	43	48	1039	812	48
Conflicting Peds, #/hr	0	0	0	0	0	0
Sign Control	Stop	Stop	Free	Free	Free	Free
RT Channelized	-	None	-	None	-	None
Storage Length	0	-	-	-	-	-
Veh in Median Storage, #	0	-	-	0	0	-
Grade, %	0	-	-	0	0	-
Peak Hour Factor	50	50	93	93	93	93
Heavy Vehicles, %	2	2	3	3	4	4
Mvmt Flow	64	86	52	1117	873	52

Major/Minor	Minor2	Major1	Major2			
Conflicting Flow All	1562	463	925	0	-	0
Stage 1	899	-	-	-	-	-
Stage 2	663	-	-	-	-	-
Critical Hdwy	6.84	6.94	4.16	-	-	-
Critical Hdwy Stg 1	5.84	-	-	-	-	-
Critical Hdwy Stg 2	5.84	-	-	-	-	-
Follow-up Hdwy	3.52	3.32	2.23	-	-	-
Pot Cap-1 Maneuver	103	546	728	-	-	-
Stage 1	358	-	-	-	-	-
Stage 2	474	-	-	-	-	-
Platoon blocked, %				-	-	-
Mov Cap-1 Maneuver	84	546	728	-	-	-
Mov Cap-2 Maneuver	194	-	-	-	-	-
Stage 1	291	-	-	-	-	-
Stage 2	474	-	-	-	-	-

Approach	EB	NB	SB
HCM Control Delay, s	27.3	0.5	0
HCM LOS	D		

Minor Lane/Major Mvmt	NBL	NBT	EBLn1	SBT	SBR
Capacity (veh/h)	728	-	308	-	-
HCM Lane V/C Ratio	0.071	-	0.487	-	-
HCM Control Delay (s)	10.3	-	27.3	-	-
HCM Lane LOS	B	-	D	-	-
HCM 95th %tile Q(veh)	0.2	-	2.5	-	-

Intersection						
Int Delay, s/veh	0					
Movement	EBL	EBR	NBL	NBT	SBT	SBR
Lane Configurations	T			T		
Traffic Vol, veh/h	0	0	0	1071	860	0
Future Vol, veh/h	0	0	0	1071	860	0
Conflicting Peds, #/hr	0	0	0	0	0	0
Sign Control	Stop	Stop	Free	Free	Free	Free
RT Channelized	-	None	-	None	-	None
Storage Length	0	-	-	-	-	-
Veh in Median Storage, #	0	-	-	0	0	-
Grade, %	0	-	-	0	0	-
Peak Hour Factor	50	50	94	94	93	93
Heavy Vehicles, %	2	2	3	3	4	4
Mvmt Flow	0	0	0	1139	925	0

Major/Minor	Minor2	Major1	Major2			
Conflicting Flow All	1495	463	-	0	-	0
Stage 1	925	-	-	-	-	-
Stage 2	570	-	-	-	-	-
Critical Hdwy	6.84	6.94	-	-	-	-
Critical Hdwy Stg 1	5.84	-	-	-	-	-
Critical Hdwy Stg 2	5.84	-	-	-	-	-
Follow-up Hdwy	3.52	3.32	-	-	-	-
Pot Cap-1 Maneuver	114	546	0	-	-	0
Stage 1	347	-	0	-	-	0
Stage 2	529	-	0	-	-	0
Platoon blocked, %				-	-	
Mov Cap-1 Maneuver	114	546	-	-	-	-
Mov Cap-2 Maneuver	240	-	-	-	-	-
Stage 1	347	-	-	-	-	-
Stage 2	529	-	-	-	-	-

Approach	EB	NB	SB
HCM Control Delay, s	0	0	0
HCM LOS	A		

Minor Lane/Major Mvmt	NBT	EBLn1	SBT
Capacity (veh/h)	-	-	-
HCM Lane V/C Ratio	-	-	-
HCM Control Delay (s)	-	0	-
HCM Lane LOS	-	A	-
HCM 95th %tile Q(veh)	-	-	-

Intersection						
Int Delay, s/veh	0					
Movement	EBL	EBR	NBL	NBT	SBT	SBR
Lane Configurations	T			T		
Traffic Vol, veh/h	0	0	0	1071	860	0
Future Vol, veh/h	0	0	0	1071	860	0
Conflicting Peds, #/hr	0	0	0	0	0	0
Sign Control	Stop	Stop	Free	Free	Free	Free
RT Channelized	-	None	-	None	-	None
Storage Length	0	-	-	-	-	-
Veh in Median Storage, #	0	-	-	0	0	-
Grade, %	0	-	-	0	0	-
Peak Hour Factor	50	50	93	93	93	93
Heavy Vehicles, %	2	2	3	3	4	4
Mvmt Flow	0	0	0	1152	925	0

Major/Minor	Minor2	Major1	Major2		
Conflicting Flow All	1501	463	-	0	-
Stage 1	925	-	-	-	-
Stage 2	576	-	-	-	-
Critical Hdwy	6.84	6.94	-	-	-
Critical Hdwy Stg 1	5.84	-	-	-	-
Critical Hdwy Stg 2	5.84	-	-	-	-
Follow-up Hdwy	3.52	3.32	-	-	-
Pot Cap-1 Maneuver	113	546	0	-	-
Stage 1	347	-	0	-	-
Stage 2	525	-	0	-	-
Platoon blocked, %				-	-
Mov Cap-1 Maneuver	113	546	-	-	-
Mov Cap-2 Maneuver	239	-	-	-	-
Stage 1	347	-	-	-	-
Stage 2	525	-	-	-	-

Approach	EB	NB	SB
HCM Control Delay, s	0	0	0
HCM LOS	A		

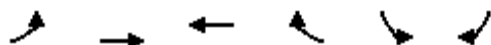
Minor Lane/Major Mvmt	NBT	EBLn1	SBT	SBR
Capacity (veh/h)	-	-	-	-
HCM Lane V/C Ratio	-	-	-	-
HCM Control Delay (s)	-	0	-	-
HCM Lane LOS	-	A	-	-
HCM 95th %tile Q(veh)	-	-	-	-

*2019 BUILD CONDITION  
CAPACITY ANALYSIS WORKSHEETS  
(PM Peak Hour – Revised)*

# Lanes, Volumes, Timings

## 4: Little Britain Road & Union Avenue

11/05/2018



Lane Group	EBL	EBT	WBT	WBR	SBL	SBR
Lane Configurations						
Traffic Volume (vph)	452	423	472	482	597	370
Future Volume (vph)	452	423	472	482	597	370
Ideal Flow (vphpl)	1900	1900	1900	1900	1900	1900
Lane Width (ft)	11	11	11	11	11	13
Storage Length (ft)	0			0	340	0
Storage Lanes	1			1	1	1
Taper Length (ft)	25				25	
Lane Util. Factor	1.00	1.00	1.00	1.00	0.97	1.00
Fr <sub>t</sub>				0.850		0.850
Fl <sub>t</sub> Protected	0.950				0.950	
Satd. Flow (prot)	1728	1818	1766	1501	3224	1589
Fl <sub>t</sub> Permitted	0.128				0.950	
Satd. Flow (perm)	233	1818	1766	1501	3224	1589
Right Turn on Red				Yes		Yes
Satd. Flow (RTOR)				92		117
Link Speed (mph)		45	45		45	
Link Distance (ft)		727	855		2865	
Travel Time (s)		11.0	13.0		43.4	
Peak Hour Factor	0.91	0.91	0.86	0.86	0.89	0.89
Heavy Vehicles (%)	1%	1%	4%	4%	5%	5%
Adj. Flow (vph)	497	465	549	560	671	416
Shared Lane Traffic (%)						
Lane Group Flow (vph)	497	465	549	560	671	416
Enter Blocked Intersection	No	No	No	No	No	No
Lane Alignment	Left	Left	Left	Right	Left	Right
Median Width(ft)		11	11		22	
Link Offset(ft)		0	0		0	
Crosswalk Width(ft)		16	16		16	
Two way Left Turn Lane					Yes	
Headway Factor	1.04	1.04	1.04	1.04	1.04	0.96
Turning Speed (mph)	15			9	15	9
Number of Detectors	1	2	2	1	1	1
Detector Template	Left	Thru	Thru	Right	Left	Right
Leading Detector (ft)	20	100	100	20	20	20
Trailing Detector (ft)	0	0	0	0	0	0
Detector 1 Position(ft)	0	0	0	0	0	0
Detector 1 Size(ft)	20	6	6	20	20	20
Detector 1 Type	Cl+Ex	Cl+Ex	Cl+Ex	Cl+Ex	Cl+Ex	Cl+Ex
Detector 1 Channel						
Detector 1 Extend (s)	0.0	0.0	0.0	0.0	0.0	0.0
Detector 1 Queue (s)	0.0	0.0	0.0	0.0	0.0	0.0
Detector 1 Delay (s)	0.0	0.0	0.0	0.0	0.0	0.0
Detector 2 Position(ft)		94	94			
Detector 2 Size(ft)		6	6			
Detector 2 Type		Cl+Ex	Cl+Ex			
Detector 2 Channel						
Detector 2 Extend (s)		0.0	0.0			
Turn Type	pm+pt	NA	NA	pm+ov	Prot	pm+ov

# Lanes, Volumes, Timings

## 4: Little Britain Road & Union Avenue

11/05/2018



Lane Group	EBL	EBT	WBT	WBR	SBL	SBR
Protected Phases	1	5	2	3	3	1
Permitted Phases	5			2		3
Detector Phase	1	5	2	3	3	1
Switch Phase						
Minimum Initial (s)	3.0	10.0	10.0	10.0	10.0	3.0
Minimum Split (s)	14.5	22.5	22.5	22.5	22.5	14.5
Total Split (s)	36.0	87.0	51.0	51.0	51.0	36.0
Total Split (%)	26.1%	63.0%	37.0%	37.0%	37.0%	26.1%
Maximum Green (s)	30.0	81.0	45.0	45.0	45.0	30.0
Yellow Time (s)	5.0	5.0	5.0	5.0	5.0	5.0
All-Red Time (s)	1.0	1.0	1.0	1.0	1.0	1.0
Lost Time Adjust (s)	0.0	0.0	0.0	0.0	0.0	0.0
Total Lost Time (s)	6.0	6.0	6.0	6.0	6.0	6.0
Lead/Lag	Lead		Lag			Lead
Lead-Lag Optimize?	Yes		Yes			Yes
Vehicle Extension (s)	2.0	2.0	2.0	2.0	2.0	2.0
Recall Mode	None	None	None	None	None	None
Act Effct Green (s)	78.0	78.0	41.7	77.8	30.1	66.4
Actuated g/C Ratio	0.65	0.65	0.35	0.65	0.25	0.55
v/c Ratio	0.94	0.39	0.90	0.56	0.83	0.45
Control Delay	57.9	11.9	56.7	11.5	52.6	13.0
Queue Delay	0.0	0.0	0.0	0.0	0.0	0.0
Total Delay	57.9	11.9	56.7	11.5	52.6	13.0
LOS	E	B	E	B	D	B
Approach Delay		35.7	33.9		37.5	
Approach LOS		D	C		D	

### Intersection Summary

Area Type: Other  
 Cycle Length: 138  
 Actuated Cycle Length: 120.2  
 Natural Cycle: 90  
 Control Type: Actuated-Uncoordinated  
 Maximum v/c Ratio: 0.94  
 Intersection Signal Delay: 35.7  
 Intersection LOS: D  
 Intersection Capacity Utilization 81.9%  
 ICU Level of Service D  
 Analysis Period (min) 15

Splits and Phases: 4: Little Britain Road & Union Avenue



Intersection						
Int Delay, s/veh	0.6					
Movement	EBL	EBR	NBL	NBT	SBT	SBR
Lane Configurations	↙	↗		↑↑	↑↑	
Traffic Vol, veh/h	5	47	38	977	985	6
Future Vol, veh/h	5	47	38	977	985	6
Conflicting Peds, #/hr	0	0	0	0	0	0
Sign Control	Stop	Stop	Free	Free	Free	Free
RT Channelized	-	None	-	None	-	None
Storage Length	0	0	-	-	-	-
Veh in Median Storage, #	0	-	-	0	0	-
Grade, %	0	-	-	0	0	-
Peak Hour Factor	81	81	98	98	96	96
Heavy Vehicles, %	8	8	4	4	5	5
Mvmt Flow	6	58	39	997	1026	6

Major/Minor	Minor2	Major1	Major2			
Conflicting Flow All	1606	516	1032	0	-	0
Stage 1	1029	-	-	-	-	-
Stage 2	577	-	-	-	-	-
Critical Hdwy	6.96	7.06	4.18	-	-	-
Critical Hdwy Stg 1	5.96	-	-	-	-	-
Critical Hdwy Stg 2	5.96	-	-	-	-	-
Follow-up Hdwy	3.58	3.38	2.24	-	-	-
Pot Cap-1 Maneuver	90	489	657	-	-	-
Stage 1	292	-	-	-	-	-
Stage 2	508	-	-	-	-	-
Platoon blocked, %				-	-	-
Mov Cap-1 Maneuver	78	489	657	-	-	-
Mov Cap-2 Maneuver	182	-	-	-	-	-
Stage 1	253	-	-	-	-	-
Stage 2	508	-	-	-	-	-

Approach	EB	NB	SB
HCM Control Delay, s	14.6	0.4	0
HCM LOS	B		

Minor Lane/Major Mvmt	NBL	NBT	EBLn1	EBLn2	SBT	SBR
Capacity (veh/h)	657	-	182	489	-	-
HCM Lane V/C Ratio	0.059	-	0.034	0.119	-	-
HCM Control Delay (s)	10.8	-	25.5	13.4	-	-
HCM Lane LOS	B	-	D	B	-	-
HCM 95th %tile Q(veh)	0.2	-	0.1	0.4	-	-

Intersection						
Int Delay, s/veh	0.3					
Movement	EBL	EBR	NBL	NBT	SBT	SBR
Lane Configurations	T			T		
Traffic Vol, veh/h	11	6	6	1004	1021	11
Future Vol, veh/h	11	6	6	1004	1021	11
Conflicting Peds, #/hr	0	0	0	0	0	0
Sign Control	Stop	Stop	Free	Free	Free	Free
RT Channelized	-	None	-	None	-	None
Storage Length	0	-	-	-	-	-
Veh in Median Storage, #	0	-	-	0	0	-
Grade, %	0	-	-	0	0	-
Peak Hour Factor	75	75	97	97	94	94
Heavy Vehicles, %	2	2	4	4	5	5
Mvmt Flow	15	8	6	1035	1086	12

Major/Minor	Minor2	Major1	Major2			
Conflicting Flow All	1622	549	1098	0	-	0
Stage 1	1092	-	-	-	-	-
Stage 2	530	-	-	-	-	-
Critical Hdwy	6.84	6.94	4.18	-	-	-
Critical Hdwy Stg 1	5.84	-	-	-	-	-
Critical Hdwy Stg 2	5.84	-	-	-	-	-
Follow-up Hdwy	3.52	3.32	2.24	-	-	-
Pot Cap-1 Maneuver	94	480	620	-	-	-
Stage 1	283	-	-	-	-	-
Stage 2	555	-	-	-	-	-
Platoon blocked, %				-	-	-
Mov Cap-1 Maneuver	92	480	620	-	-	-
Mov Cap-2 Maneuver	204	-	-	-	-	-
Stage 1	276	-	-	-	-	-
Stage 2	555	-	-	-	-	-

Approach	EB	NB	SB
HCM Control Delay, s	20.4	0.1	0
HCM LOS	C		

Minor Lane/Major Mvmt	NBL	NBT	EBLn1	SBT	SBR
Capacity (veh/h)	620	-	256	-	-
HCM Lane V/C Ratio	0.01	-	0.089	-	-
HCM Control Delay (s)	10.9	-	20.4	-	-
HCM Lane LOS	B	-	C	-	-
HCM 95th %tile Q(veh)	0	-	0.3	-	-



Intersection						
Int Delay, s/veh	1.6					
Movement	EBL	EBR	NBL	NBT	SBT	SBR
Lane Configurations	T			↑↑		↑↑
Traffic Vol, veh/h	39	38	49	971	982	45
Future Vol, veh/h	39	38	49	971	982	45
Conflicting Peds, #/hr	0	0	0	0	0	0
Sign Control	Stop	Stop	Free	Free	Free	Free
RT Channelized	-	None	-	None	-	None
Storage Length	0	-	-	-	-	-
Veh in Median Storage, #	0	-	-	0	0	-
Grade, %	0	-	-	0	0	-
Peak Hour Factor	75	75	97	97	94	94
Heavy Vehicles, %	2	2	4	4	5	5
Mvmt Flow	52	51	51	1001	1045	48

Major/Minor	Minor2	Major1	Major2			
Conflicting Flow All	1672	547	1093	0	-	0
Stage 1	1069	-	-	-	-	-
Stage 2	603	-	-	-	-	-
Critical Hdwy	6.84	6.94	4.18	-	-	-
Critical Hdwy Stg 1	5.84	-	-	-	-	-
Critical Hdwy Stg 2	5.84	-	-	-	-	-
Follow-up Hdwy	3.52	3.32	2.24	-	-	-
Pot Cap-1 Maneuver	87	481	623	-	-	-
Stage 1	291	-	-	-	-	-
Stage 2	509	-	-	-	-	-
Platoon blocked, %				-	-	-
Mov Cap-1 Maneuver	71	481	623	-	-	-
Mov Cap-2 Maneuver	171	-	-	-	-	-
Stage 1	237	-	-	-	-	-
Stage 2	509	-	-	-	-	-

Approach	EB	NB	SB
HCM Control Delay, s	28.9	0.5	0
HCM LOS	D		

Minor Lane/Major Mvmt	NBL	NBT	EBLn1	SBT	SBR
Capacity (veh/h)	623	-	251	-	-
HCM Lane V/C Ratio	0.081	-	0.409	-	-
HCM Control Delay (s)	11.3	-	28.9	-	-
HCM Lane LOS	B	-	D	-	-
HCM 95th %tile Q(veh)	0.3	-	1.9	-	-



Ecological Solutions Threatened & Endangered  
Species Habitat Suitability Report April 14,  
2018



*Threatened and Endangered Species  
Habitat Suitability Assessment Report*

Limited Service Hotel Site  
935 Union Avenue  
Town of New Windsor, Orange County, New York

April 14, 2018

Prepared by:

**Michael Nowicki**  
Ecological Solutions, LLC  
1248 Southford Road  
Southbury, CT 06488  
(203) 910-4716



<b>1.0 INTRODUCTION</b>	<b>3</b>
TABLE 1 HABITAT COVER TYPES and PROPOSED IMPACTS.....	3
<b>2.0 HABITAT SUITABILITY ASSESSMENT/CONCLUSION</b>	<b>4</b>
<b>2.1 Dwarf wedgemussel</b> .....	<b>4</b>
<b>2.1 Small whorled pogonia</b> .....	<b>4</b>
<b>2.3 Indiana bats</b> .....	<b>4</b>
<b>2.4 Northern long-eared bat</b> .....	<b>5</b>
<b>2.5 Bog turtle</b> .....	<b>5</b>
<b>3.0 PHOTOGRAPHS</b>	<b>7</b>
Figure 1 Location Map .....	10
Attachment 1 USFWS List .....	11
Attachment 2 NYSDEC Map .....	12





## 1.0 INTRODUCTION

The Applicant is proposing the conversion of an existing restaurant to a 4 story hotel use with a small increase to currently undeveloped land that will be converted to parking area amounting to about 0.1 acres of the 2.8 acres site located at 935 Union Avenue in the Town of New Windsor, Orange County, New York (*Figure 1*). The site currently contains a restaurant, parking lot, and associated features.

A Habitat Suitability Assessment was completed for five federally listed species including the Indiana bat (*Myotis sodalis*), Northern long-eared bat (*Myotis septentrionalis*), small whorled pogonia (*Isotria medeoloides*), dwarf wedgemussel (*Alasmidonta heterodon*), and bog turtle (*Glyptemys muhlenbergii*) as described in the US Fish and Wildlife Service (USFWS) list for the area in New Windsor (*Attachment*). The New York State Department of Environmental Conservation (NYSDEC) Environmental Resource Mapper was also reviewed and indicated that bats are potentially located in this area of New Windsor (*Attachment 2*). A field assessment of habitat conditions was conducted on April 13, 2018.

Habitat cover types are described below. There is one distinct natural cover type identified on the site. Approximate physical impacts to each habitat type are shown and listed in *Table 1*.

**TABLE 1**  
**HABITAT COVER TYPES and PROPOSED IMPACTS**

NO.		ACRES IDENTIFIED (APPROXIMATE)	PROPOSED IMPACTS
1	Developed Area	2.50	2.50
2	Mowed Field Area	0.30	0.10
<b>Total</b>		2.80	0.10

### Mowed Field

Most of the site is already developed with a restaurant, parking area, access road, and landscaping. The remaining property is maintained field with patch of wooded area containing trees about 2 inches dbh and about 5 large oak trees about 18 inches dbh located at the boundary of the field area to the east. Species noted in the area of the site included ash, maple, and oak.

## 2.0 HABITAT SUITABILITY ASSESSMENT/CONCLUSION

### 2.1 Dwarf wedgemussel

The dwarf wedge mussel is a small freshwater mussel that rarely exceeds 1.5 inches (38 mm) in length. It is brown or yellowish-brown in color. Adult mussels are filter-feeders, feeding on algae and other small suspended particles. They spend most of their time buried almost completely in the bottom of streams and rivers. Typical habitat for this mussel includes running waters of all sizes, from small brooks to large rivers. Bottom substrates include silt, sand and gravel, which may be distributed in relatively small patches behind larger cobbles and boulders. The river velocity is usually slow to moderate. Dwarf wedge mussels appear to select or are at least tolerant of relatively low levels of calcium in the water.

**Conclusion** - There is no potential habitat for this species on the site since there are no tributaries located on the site.

### 2.1 Small whorled pogonia

The small whorled pogonia is a member of the orchid family. It usually has a single grayish-green stem that grows about 10 inches tall when in flower and about 14 inches when bearing fruit. The plant is named for the whorl of five or six leaves near the top of the stem and beneath the flower. The leaves are grayish-green, somewhat oblong and 1 to 3.5 inches long. The single or paired greenish-yellow flowers are about 0.5 to 1 inch long and appear in May or June. The fruit, an upright ellipsoid capsule, appears later in the year. This orchid grows in older hardwood stands of beech, birch, maple, oak, and hickory that have an open understory. Sometimes it grows in stands of softwoods such as hemlock. It prefers acidic soils with a thick layer of dead leaves, often on slopes near small streams.

**Conclusion** - There is no potential habitat for this species on the site since there is no older forest or wooded area.

### 2.3 Indiana bats

The Indiana bat typically hibernates in caves/mines in the winter and roosts under bark or in tree crevices in the spring, summer, and fall. Suitable potential summer roosting habitat is characterized by trees (dead, dying, or alive) or snags with exfoliating or defoliating bark, or containing cracks or crevices that could potentially be used by Indiana bats as a roost. The minimum diameter of roost trees observed to date is 2.5 inches for males and 4.3 inches for females. However, maternity colonies generally use trees greater than or equal to 9 inches dbh. Overall, roost tree structure appears to be more important to Indiana bats than a particular tree species or habitat type. Females appear to be more habitat specific than males presumably because of the warmer temperature requirements associated with gestation and rearing of young. As a result, they are generally found at lower elevations than males may be found. Roosts are warmed by direct exposure to solar radiation, thus trees exposed to extended periods of direct sunlight are preferred over those in shaded areas. However, shaded roosts may be preferred in very hot conditions. As

larger trees afford a greater thermal mass for heat retention, they appear to be preferred over smaller trees. While Indiana bats appear to forage in a wide variety of habitats, they seem to tend to stay fairly close to tree cover.

**Conclusion** - The site is generally developed except for a maintained field area with a small wooded fringe along the property boundary. The trees are generally young growth with a 2 inch dbh average and not over 25 feet tall. These trees are sporadically located and do not offer any characteristics associated with Indiana bat roosting or maternal colony use. The project is not likely to adversely affect this species and no conservation measures are proposed since no large tree removal is proposed.

## 2.4 Northern long-eared bat

**Winter Habitat:** Same as the Indiana bat northern long-eared bats spend winter hibernating in caves and mines, called hibernacula. They typically use large caves or mines with large passages and entrances; constant temperatures; and high humidity with no air currents. Specific areas where they hibernate have very high humidity, so much so that droplets of water are often seen on their fur. Within hibernacula, surveyors find them in small crevices or cracks, often with only the nose and ears visible.

**Summer Habitat:** During summer, northern long-eared bats roost singly or in colonies underneath bark, in cavities, or in crevices of both live and dead trees. Males and non-reproductive females may also roost in cooler places, like caves and mines. This bat seems opportunistic in selecting roosts, using tree species based on suitability to retain bark or provide cavities or crevices. It has also been found, rarely, roosting in structures like barns and sheds.

**Feeding Habits:** Northern long-eared bats emerge at dusk to fly through the understory of forested hillsides and ridges feeding on moths, flies, leafhoppers, caddisflies, and beetles, which they catch while in flight using echolocation. This bat also feeds by gleaning motionless insects from vegetation and water surfaces.

**Conclusion** - The northern long eared bat requires/occupies practically the same habitat niche as the Indiana bat. The project is not likely to adversely affect this species.

## 2.5 Bog turtle

According to the U.S. Fish and Wildlife Service, in the 2001 Bog Turtle (*Clemmys muhlenbergii*), Northern Population Recovery Plan. Hadley, Massachusetts. 103 pp. last revised on April 13, 2006 bog turtle habitat is recognized by three criteria:

1. **Suitable hydrology.** Bog turtle wetlands are typically spring-fed with shallow surface water or saturated soils present year-round, although in summer the wet area(s) may be restricted to near spring head(s). Typically these wetlands are interspersed with dry and wet pockets. There is often subsurface flow. In addition, shallow rivulets (less than 4 inches deep) or pseudo-rivulets are often present.

**2. Suitable soils.** Usually a bottom substrate of permanently saturated organic or mineral soils. These are often soft, mucky-like soils (this does not refer to a technical soil type); you will usually sink to your ankles (3-5 inches) or deeper in muck, although in degraded wetlands or summers of dry years this may be limited to areas near spring heads or drainage ditches. In some portions of the species' range, the soft substrate consists of scattered pockets of peat instead of muck.

**3. Suitable vegetation.** Dominant vegetation of low grasses and sedges (in emergent wetlands), often with a scrub-shrub wetland component. Common emergent vegetation includes, but is not limited to: tussock sedge (*Carex stricta*), soft rush (*Juncus effusus*), rice cut grass (*Leersia oryzoides*), sensitive fern (*Onoclea sensibilis*), tearthumbs (*Polygonum spp.*), jewelweeds (*Impatiens spp.*), arrowheads (*Sagittaria spp.*), skunk cabbage (*Symplocarpus foetidus*), panic grasses (*Panicum spp.*), other sedges (*Carex spp.*), spike rushes (*Eleocharis spp.*), grass-of-Parnassus (*Parnassia glauca*), shrubby cinquefoil (*Dasiphora fruticosa*), sweet-flag (*Acorus calamus*), and in disturbed sites, reed canary grass (*Phalaris arundinacea*) or purple loosestrife (*Lythrum salicaria*). Common scrub-shrub species include alder (*Alnus spp.*), red maple (*Acer rubrum*), willow (*Salix spp.*), tamarack (*Larix laricina*), and in disturbed sites, multiflora rose (*Rosa multiflora*). Some forested wetland habitats are suitable given hydrology, soils and/or historic land use. These forested wetlands include red maple, tamarack, and cedar swamps.

**Conclusion** – There are no wetlands on the site or adjacent to the site and therefore no potential bog turtle habitat in this location. No conservation measures are proposed.

### 3.0 PHOTOGRAPHS

Trees on eastern part of site to remain





Area of additional parking



Existing site development





Figure 1 Location Map





## Attachment 1 USFWS List





## United States Department of the Interior



FISH AND WILDLIFE SERVICE  
New York Ecological Services Field Office  
3817 Luker Road  
Cortland, NY 13045-9385

Phone: (607) 753-9334 Fax: (607) 753-9699

<http://www.fws.gov/northeast/nyfo/es/section7.htm>

In Reply Refer To:

April 14, 2018

Consultation Code: 05E1NY00-2018-SLI-1763

Event Code: 05E1NY00-2018-E-05380

Project Name: 935 Union Avenue - Hotel

Subject: List of threatened and endangered species that may occur in your proposed project location, and/or may be affected by your proposed project

To Whom It May Concern:

The enclosed species list identifies threatened, endangered, proposed and candidate species, as well as proposed and final designated critical habitat, that may occur within the boundary of your proposed project and/or may be affected by your proposed project. The species list fulfills the requirements of the U.S. Fish and Wildlife Service (Service) under section 7(c) of the Endangered Species Act (ESA) of 1973, as amended (16 U.S.C. 1531 *et seq.*). This list can also be used to determine whether listed species may be present for projects without federal agency involvement. New information based on updated surveys, changes in the abundance and distribution of species, changed habitat conditions, or other factors could change this list.

Please feel free to contact us if you need more current information or assistance regarding the potential impacts to federally proposed, listed, and candidate species and federally designated and proposed critical habitat. Please note that under 50 CFR 402.12(e) of the regulations implementing section 7 of the ESA, the accuracy of this species list should be verified after 90 days. This verification can be completed formally or informally as desired. The Service recommends that verification be completed by visiting the ECOS-IPaC site at regular intervals during project planning and implementation for updates to species lists and information. An updated list may be requested through the ECOS-IPaC system by completing the same process used to receive the enclosed list. If listed, proposed, or candidate species were identified as potentially occurring in the project area, coordination with our office is encouraged. Information on the steps involved with assessing potential impacts from projects can be found at: <http://www.fws.gov/northeast/nyfo/es/section7.htm>

Please be aware that bald and golden eagles are protected under the Bald and Golden Eagle Protection Act (16 U.S.C. 668 *et seq.*), and projects affecting these species may require development of an eagle conservation plan (<http://www.fws.gov/windenergy/>)

[eagle\\_guidance.html](#)). Additionally, wind energy projects should follow the Services wind energy guidelines (<http://www.fws.gov/windenergy/>) for minimizing impacts to migratory birds and bats.

Guidance for minimizing impacts to migratory birds for projects including communications towers (e.g., cellular, digital television, radio, and emergency broadcast) can be found at: <http://www.fws.gov/migratorybirds/CurrentBirdIssues/Hazards/towers/towers.htm>; <http://www.towerkill.com>; and <http://www.fws.gov/migratorybirds/CurrentBirdIssues/Hazards/towers/comtow.html>.

We appreciate your concern for threatened and endangered species. The Service encourages Federal agencies to include conservation of threatened and endangered species into their project planning to further the purposes of the ESA. Please include the Consultation Tracking Number in the header of this letter with any request for consultation or correspondence about your project that you submit to our office.

Attachment(s):

- Official Species List

## Official Species List

This list is provided pursuant to Section 7 of the Endangered Species Act, and fulfills the requirement for Federal agencies to "request of the Secretary of the Interior information whether any species which is listed or proposed to be listed may be present in the area of a proposed action".

This species list is provided by:

**New York Ecological Services Field Office**

3817 Luker Road

Cortland, NY 13045-9385

(607) 753-9334

---

## Project Summary

Consultation Code: 05E1NY00-2018-SLI-1763

Event Code: 05E1NY00-2018-E-05380

Project Name: 935 Union Avenue - Hotel

Project Type: DEVELOPMENT

Project Description: Parking expansion for existing hotel

Project Location:

Approximate location of the project can be viewed in Google Maps: <https://www.google.com/maps/place/41.494250444943404N74.07533953377754W>



Counties: Orange, NY

---

## Endangered Species Act Species

There is a total of 5 threatened, endangered, or candidate species on this species list.

Species on this list should be considered in an effects analysis for your project and could include species that exist in another geographic area. For example, certain fish may appear on the species list because a project could affect downstream species.

IPaC does not display listed species or critical habitats under the sole jurisdiction of NOAA Fisheries<sup>1</sup>, as USFWS does not have the authority to speak on behalf of NOAA and the Department of Commerce.

See the "Critical habitats" section below for those critical habitats that lie wholly or partially within your project area under this office's jurisdiction. Please contact the designated FWS office if you have questions.

- 
1. [NOAA Fisheries](#), also known as the National Marine Fisheries Service (NMFS), is an office of the National Oceanic and Atmospheric Administration within the Department of Commerce.

## Mammals

NAME	STATUS
Indiana Bat <i>Myotis sodalis</i> There is <b>final</b> critical habitat for this species. Your location is outside the critical habitat. Species profile: <a href="https://ecos.fws.gov/ecp/species/5949">https://ecos.fws.gov/ecp/species/5949</a>	Endangered
Northern Long-eared Bat <i>Myotis septentrionalis</i> No critical habitat has been designated for this species. Species profile: <a href="https://ecos.fws.gov/ecp/species/9045">https://ecos.fws.gov/ecp/species/9045</a>	Threatened

## Reptiles

NAME	STATUS
Bog Turtle <i>Clemmys muhlenbergii</i> Population: Wherever found, except GA, NC, SC, TN, VA No critical habitat has been designated for this species. Species profile: <a href="https://ecos.fws.gov/ecp/species/6962">https://ecos.fws.gov/ecp/species/6962</a> Species survey guidelines: <a href="https://ecos.fws.gov/ipac/guideline/survey/population/182/office/52410.pdf">https://ecos.fws.gov/ipac/guideline/survey/population/182/office/52410.pdf</a> Habitat assessment guidelines: <a href="https://ecos.fws.gov/ipac/guideline/assessment/population/182/office/52410.pdf">https://ecos.fws.gov/ipac/guideline/assessment/population/182/office/52410.pdf</a>	Threatened

---

## Clams

NAME	STATUS
Dwarf Wedgemussel <i>Alasmidonta heterodon</i> No critical habitat has been designated for this species. Species profile: <a href="https://ecos.fws.gov/ecp/species/784">https://ecos.fws.gov/ecp/species/784</a> Species survey guidelines: <a href="https://ecos.fws.gov/ipac/guideline/survey/population/363/office/52410.pdf">https://ecos.fws.gov/ipac/guideline/survey/population/363/office/52410.pdf</a>	Endangered

## Flowering Plants

NAME	STATUS
Small Whorled Pogonia <i>Isotria medeoloides</i> No critical habitat has been designated for this species. Species profile: <a href="https://ecos.fws.gov/ecp/species/1890">https://ecos.fws.gov/ecp/species/1890</a> Species survey guidelines: <a href="https://ecos.fws.gov/ipac/guideline/survey/population/742/office/52410.pdf">https://ecos.fws.gov/ipac/guideline/survey/population/742/office/52410.pdf</a>	Threatened

## Critical habitats

THERE ARE NO CRITICAL HABITATS WITHIN YOUR PROJECT AREA UNDER THIS OFFICE'S JURISDICTION.

---



## Attachment 2 NYSDEC Map



# NEW YORK STATE DEPARTMENT OF ENVIRONMENTAL CONSERVATION

Division of Fish and Wildlife, New York Natural Heritage Program  
625 Broadway, Fifth Floor, Albany, NY 12233-4757  
P: (518) 402-8935 | F: (518) 402-8925  
www.dec.ny.gov

May 3, 2018

Michael Nowicki  
Ecological Solutions, LLC  
1248 Southford Road  
Southbury, CT 06488

Re: 935 Union Avenue - Hotel  
County: Orange Town/City: New Windsor

Dear Mr. Nowicki:

In response to your recent request, we have reviewed the New York Natural Heritage Program database with respect to the above project.

Enclosed is a report of rare or state-listed animals and plants, and significant natural communities that our database indicates occur in the vicinity of the project site. Given the location and nature of the proposed work, significant impacts on these species may not be expected. However, an official determination regarding any permit considerations for the project should be obtained from the Permits staff at the NYSDEC Region 3 Office; please contact them at [dep.r3@dec.ny.gov](mailto:dep.r3@dec.ny.gov), (845) 256-3054.

For most sites, comprehensive field surveys have not been conducted; the enclosed report only includes records from our database. We cannot provide a definitive statement as to the presence or absence of all rare or state-listed species or significant natural communities. Depending on the nature of the project and the conditions at the project site, further information from on-site surveys or other sources may be required to fully assess impacts on biological resources.

The presence of the plants and animals identified in the enclosed report may result in this project requiring additional review or permit conditions. For further guidance, and for information regarding other permits that may be required under state law for regulated areas or activities (e.g., regulated wetlands), please contact the NYS DEC Region 3 Office, Division of Environmental Permits, as described above.

Sincerely,



Nicholas Conrad  
Information Resources Coordinator  
New York Natural Heritage Program



**The following state-listed animals have been documented in the vicinity of the project site.**

The following list includes animals that are listed by NYS as Endangered, Threatened, or Special Concern; and/or that are federally listed or are candidates for federal listing.

**For information about any permit considerations for the project, please contact the Permits staff at the NYSDEC Region 3 Office at [dep.r3@dec.ny.gov](mailto:dep.r3@dec.ny.gov), (845) 256-3054. For information about potential impacts of the project on these species, and how to avoid, minimize, or mitigate any impacts, contact the Region 3 Wildlife staff at [Wildlife.R3@dec.ny.gov](mailto:Wildlife.R3@dec.ny.gov), (845) 256-3098.**

**The following species have been documented about .5 mile from the project site.**

<i>COMMON NAME</i>	<i>SCIENTIFIC NAME</i>	<i>NY STATE LISTING</i>	<i>FEDERAL LISTING</i>
<b>Upland Sandpiper</b> <i>Breeding</i>	<i>Bartramia longicauda</i>	Threatened	7655

**The following species have been documented about two miles from the project site. Individual animals may travel 2.5 miles from documented locations. The main concern for bats is the removal or cutting of potential roost trees.**

<i>COMMON NAME</i>	<i>SCIENTIFIC NAME</i>	<i>NY STATE LISTING</i>	<i>FEDERAL LISTING</i>
<b>Indiana Bat</b> <i>Non-winter location</i>	<i>Myotis sodalis</i>	Endangered	Endangered 13890

This report only includes records from the NY Natural Heritage database.

If any rare plants or animals are documented during site visits, we request that information on the observations be provided to the New York Natural Heritage Program so that we may update our database.

Information about many of the listed animals in New York, including habitat, biology, identification, conservation, and management, are available online in Natural Heritage’s Conservation Guides at [www.guides.nynhp.org](http://www.guides.nynhp.org), and from NYSDEC at [www.dec.ny.gov/animals/7494.html](http://www.dec.ny.gov/animals/7494.html).

## **C. Exhibits**

- Exhibit 1 - Existing Conditions Survey
- Exhibit 2 - Building Elevations
- Exhibit 3 - Site Plan
- Exhibit 4 - Landscaping Plan
- Exhibit 5 - Lighting Plan
- Exhibit 6 - Orange County Soils Survey – Sheet 31
- Exhibit 7 - Grading, Soil & Erosion Control Plan
- Exhibit 8 - Section thru Property & Buildings



# Exhibit 1 - Existing Site Conditions Survey





**LEGEND**

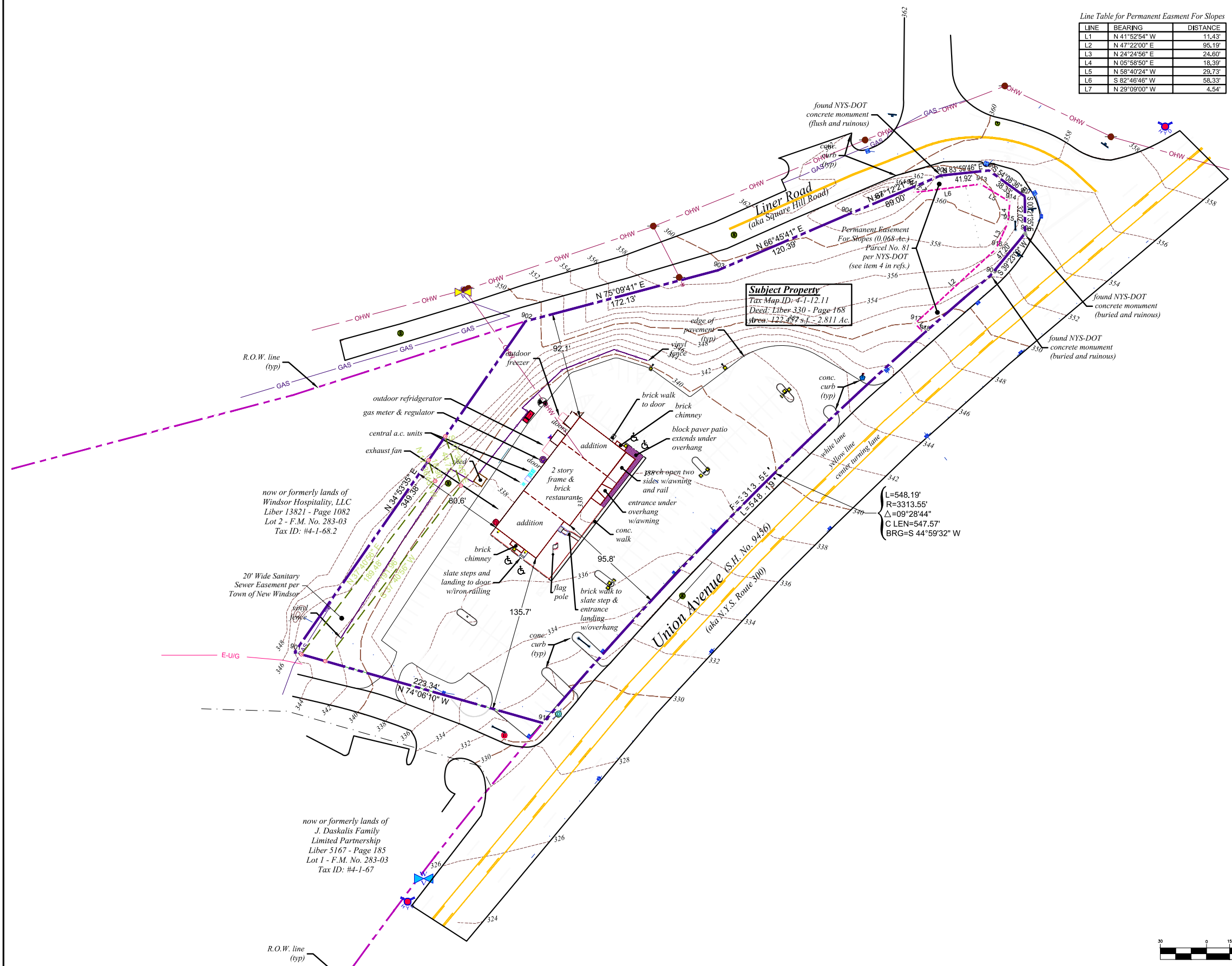
- EXISTING PROPERTY LINE
- EXISTING 10 FT CONTOUR LINE
- EXISTING 2 FT CONTOUR LINE
- EXISTING TREE LINE
- EXISTING TREES
- EXISTING SIGN
- EXISTING CATCH BASIN
- EXISTING SANITARY MANHOLE
- EXISTING WATER VALVE
- EXISTING UTILITY POLE
- EXISTING FENCELINE
- EXISTING OVERHEAD WIRE
- EXISTING SANITARY SEWER LINE
- EXISTING WATER MAIN

**SITE NOTES**

1. PROPERTY BOUNDARY, TOPOGRAPHY AND EXISTING UTILITY SHOWN HEREON ARE BASED ON A SURVEY ENTITLED "BOUNDARY & TOPOGRAPHIC SURVEY OF THE LANDS OF BANTA REALTY" PREPARED BY JONATHAN N. MILLEN, L.L.S., DATED MARCH 24, 2017.

Line Table for Permanent Easement For Slopes

LINE	BEARING	DISTANCE
L1	N 41°52'54" W	11.43'
L2	N 47°22'00" E	95.19'
L3	N 24°24'56" E	24.60'
L4	N 05°58'50" E	18.39'
L5	N 58°40'24" W	29.73'
L6	S 82°46'46" W	58.33'
L7	N 29°09'00" W	4.54'




**Town of New Windsor  
Planning Board Approval**

NWPB Project No. 17-04

Tax Map Parcel No. 4-1-12.11 (2.81 Ac)

IT IS A VIOLATION OF NEW YORK STATE EDUCATION LAW FOR ANY PERSONS TO ALTER THESE PLANS, SPECIFICATIONS, OR REPORTS IN ANY WAY, UNLESS ACTING UNDER THE DIRECTION OF A LICENSED PROFESSIONAL ENGINEER OR LAND SURVEYOR.

	Mark A. Day, PE
	
January 15, 2019	
May 5, 2017	
2016:003	License No. 069646

**M.A. DAY Engineering, PC**  
Consulting Engineers

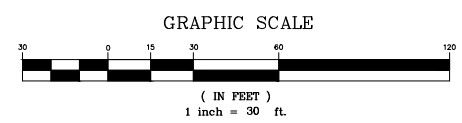
3 Van Wyck Lane Suite 2  
Wappingers Falls, New York  
(845)-223-3202

**935 Union Ave**

Town of New Windsor      Orange County, NY

**Existing Conditions**

SCALE 1" = 30'	DRAWN BY CJV	DRAWING NO. <b>VE101</b>
DATE 04-07-17	CHECKED BY DJL	2 of 16





# Exhibit 2 - Building Elevations



**B**  
**BLAKE ENGINEERING, PLLC**  
 1000 WEST 17TH AVENUE, SUITE 1000  
 DENVER, COLORADO 80202  
 303.733.1100  
 www.blake-engineering.com

**M.A. DAY Engineering, PC**  
 1100 West 14th Avenue  
 Suite 200  
 Englewood, Colorado 80110  
 303.733.1100  
 www.maday.com

**IA WHALEN ARCHITECTURE, P.C.**  
 1100 West 14th Avenue  
 Suite 200  
 Englewood, Colorado 80110  
 303.733.1100  
 www.iawhalen.com

© 2014 InterContinental Hotels Group. All rights reserved. No part of this document may be reproduced, stored in a retrieval system, or transmitted in any form or by any means, electronic, mechanical, photocopying, recording, or by any information storage and retrieval system, without the express written permission of InterContinental Hotels Group.

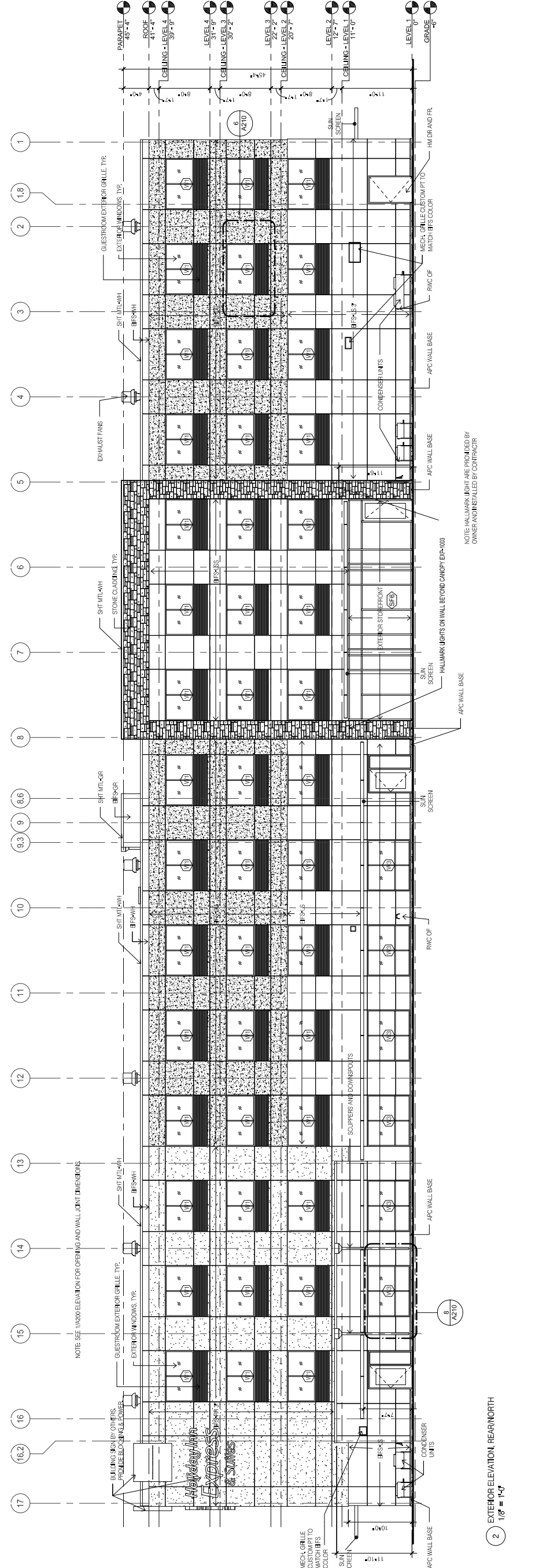
THIS DOCUMENT IS A PRELIMINARY DESIGN AND SHOULD NOT BE USED FOR CONSTRUCTION. THE CONTRACTOR SHALL VERIFY ALL DIMENSIONS AND CONDITIONS ON SITE OR CERTAIN LOCAL CONDITIONS. THE CONTRACTOR SHALL BE RESPONSIBLE FOR OBTAINING ALL NECESSARY PERMITS AND APPROVALS. THE CONTRACTOR SHALL BE RESPONSIBLE FOR OBTAINING ALL NECESSARY PERMITS AND APPROVALS. THE CONTRACTOR SHALL BE RESPONSIBLE FOR OBTAINING ALL NECESSARY PERMITS AND APPROVALS.

Project Title  
 2014 Holiday Inn Express  
 Prototype, Straight Pavilion.  
 Client  
 InterContinental Hotels Group

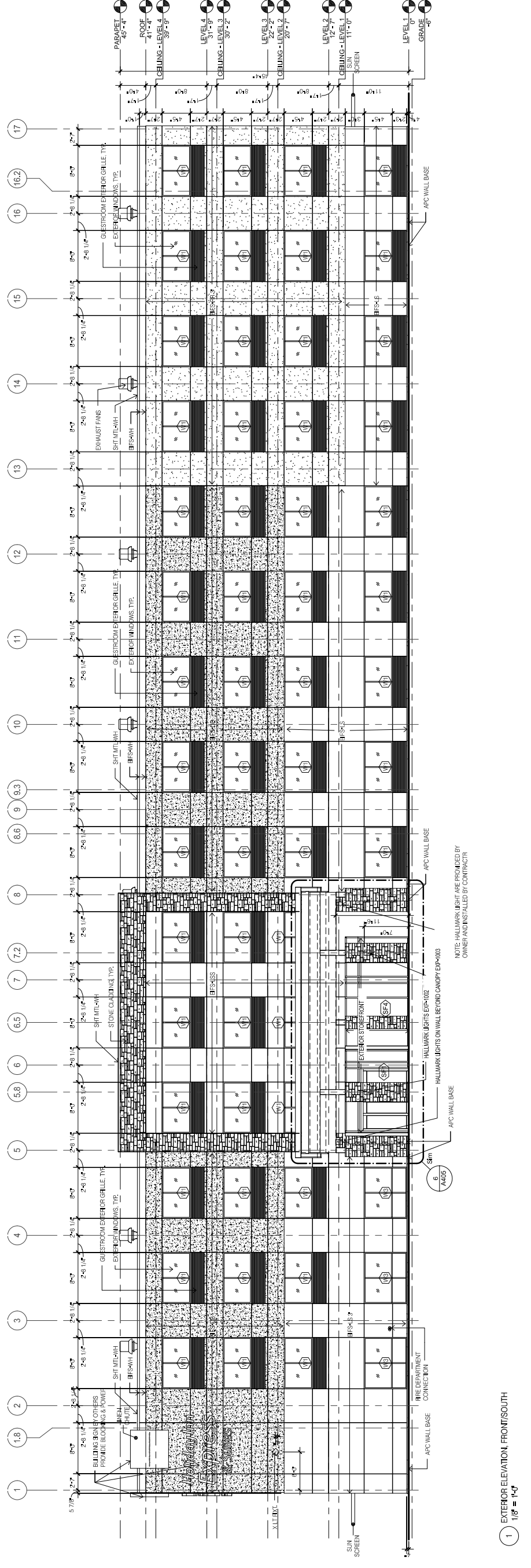
Printed Name	
Signature	
Date Issued	
Rev. No.	
Description	
Date	8/21/17
FOR REVIEW	
Product number	6935.09
Date	08/08/14
Drawn by	EBJUB
Checked by	JRCK

**EXTERIOR ELEVATIONS**

**A200**



2 EXTERIOR ELEVATION FRONT/NORTH  
 1/8" = 1'-0"



1 EXTERIOR ELEVATION FRONT/SOUTH  
 1/8" = 1'-0"

FOR REVIEW ONLY  
 NOT FOR CONSTRUCTION 8/21/17





BLAKE ENGINEERING, PLLC  
 1000 WEST 10TH AVENUE, SUITE 1000  
 DENVER, COLORADO 80202  
 TEL: 303.733.1100  
 FAX: 303.733.1101  
 WWW.BLAKEENGINEERING.COM

**M.A. DAY Engineering, PC**  
 1100 17th Lane  
 Suite 200  
 Englewood, CO 80110  
 303.733.1100



**WAHLEN ARCHITECTURE, PC**  
 1700 W. ALAMO AVENUE, SUITE 1000  
 DENVER, COLORADO 80202  
 TEL: 303.733.1100  
 FAX: 303.733.1101  
 WWW.WAHLENARCHITECTURE.COM

©2014 InterContinental Hotels Group. ALL RIGHTS RESERVED. NO PART OF THIS DOCUMENT IS TO BE REPRODUCED, COPIED, REPRODUCED, DISCLOSED OR TRANSFERRED IN ANY MANNER WITHOUT THE EXPRESS WRITTEN PERMISSION OF INTERCONTINENTAL HOTELS GROUP.

THIS DOCUMENT IS THE PROPERTY OF INTERCONTINENTAL HOTELS GROUP. IT IS TO BE USED ONLY FOR THE PROJECT AND SITE SPECIFICALLY IDENTIFIED HEREIN. IT IS NOT TO BE REPRODUCED, COPIED, REPRODUCED, DISCLOSED OR TRANSFERRED IN ANY MANNER WITHOUT THE EXPRESS WRITTEN PERMISSION OF INTERCONTINENTAL HOTELS GROUP.

**Project Title**  
 2014 Holiday Inn Express  
 Prototype, Straight Pavilion.  
**Client**  
 InterContinental Hotels Group

**Printed Name**  
**Signature**  
**Date Issued**  
**Rev. No.**  
**No.**

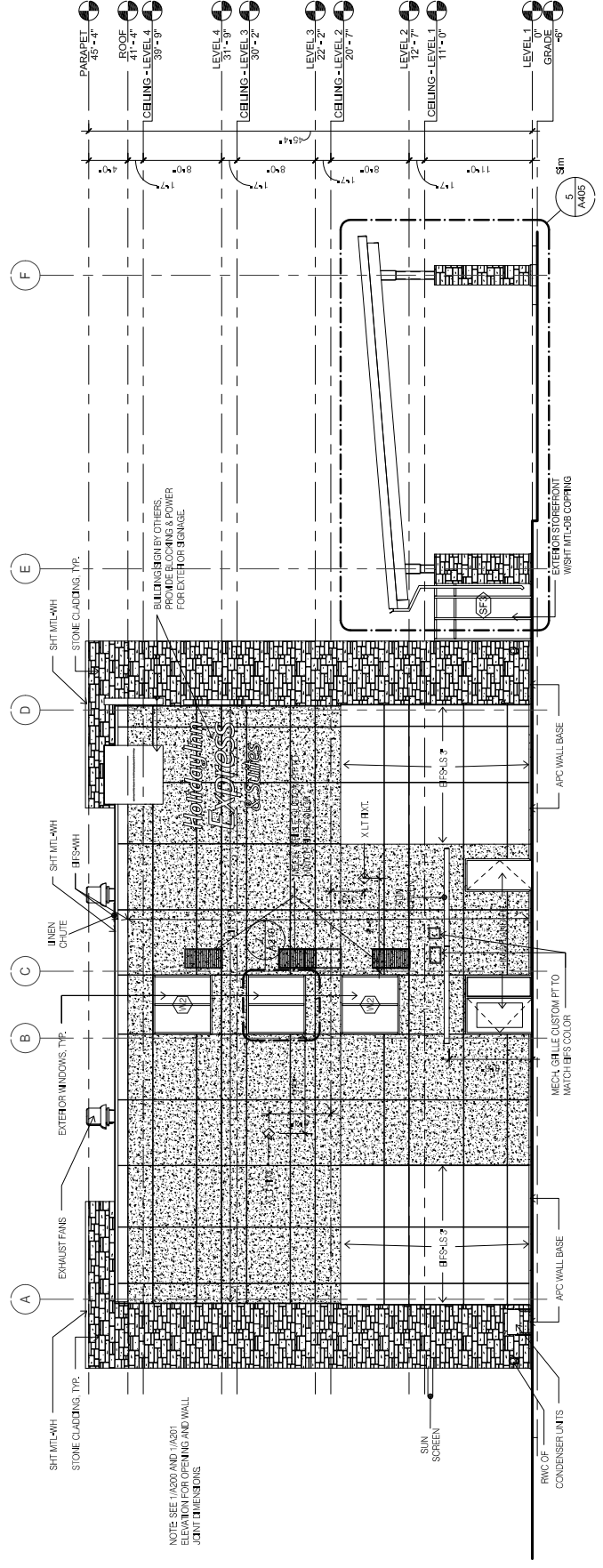
**Description**  
 FOR REVIEW

**Date**  
 8/21/17

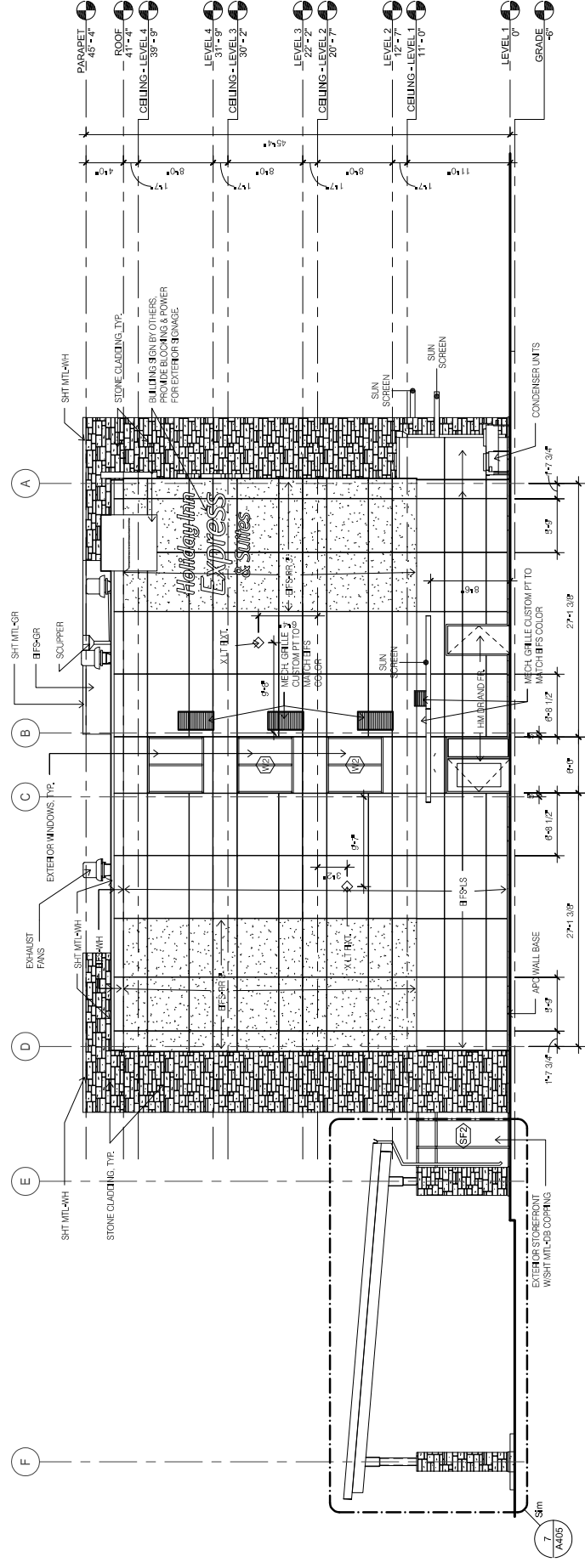
**Product number**  
 6935.09  
**Drawn by**  
 EB/JB  
**Date**  
 08/08/14  
**Checked by**  
 JR/CK

**EXTERIOR ELEVATIONS**

**A201**



2 EXTERIOR ELEVATION, WEST  
 1/8" = 1'-0"



1 EXTERIOR ELEVATION, EAST  
 1/8" = 1'-0"

FOR REVIEW ONLY  
 NOT FOR CONSTRUCTION 8/21/17

# Exhibit 3 - Site Plan



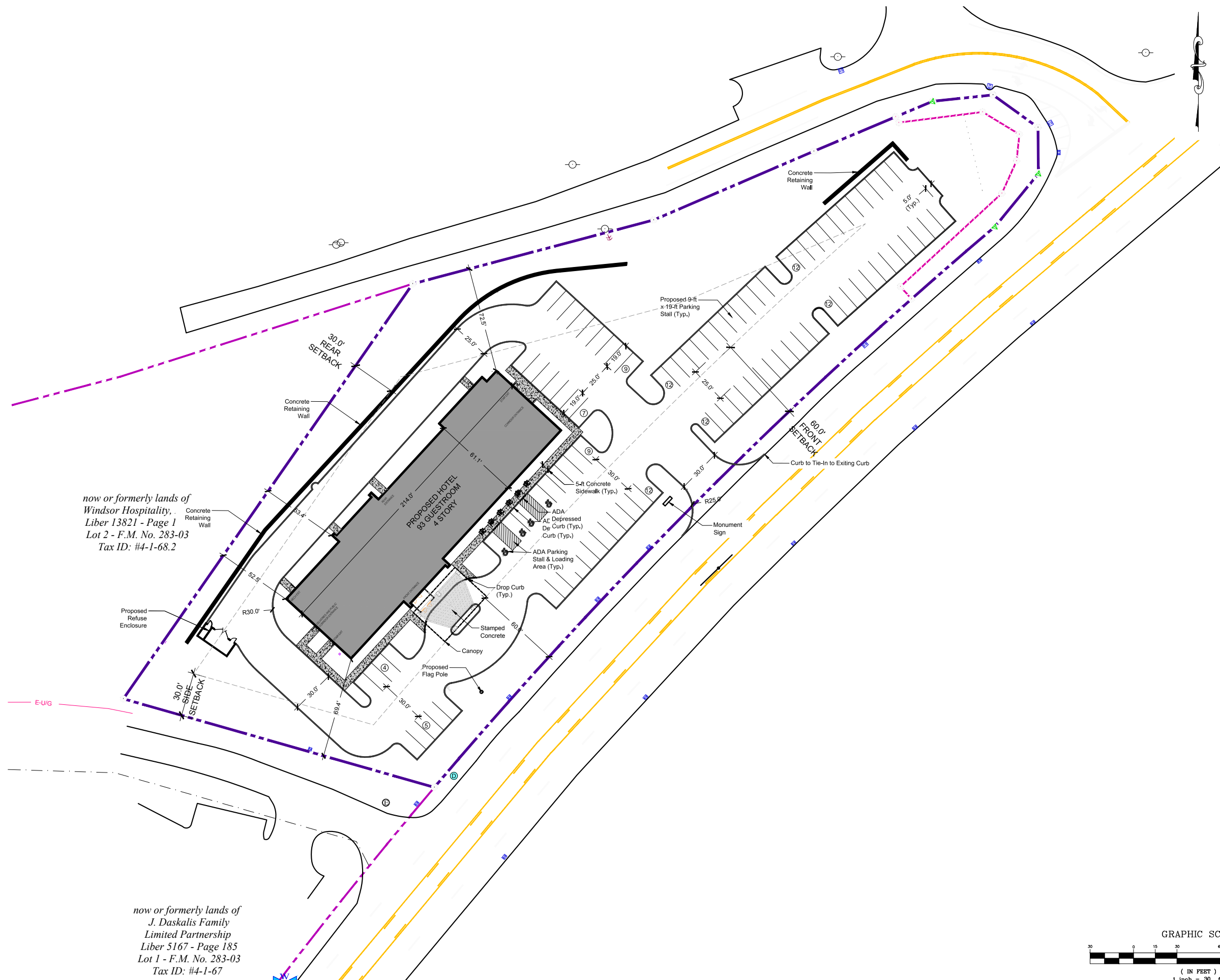


**LEGEND**

- EXISTING PROPERTY LINE
- - - - - EXISTING 10 FT CONTOUR LINE
- - - - - EXISTING 2 FT CONTOUR LINE
- \* \* \* \* \* EXISTING TREE LINE
- ⊗ EXISTING TREES
- ⊕ EXISTING SIGN
- ⊞ EXISTING CATCH BASIN
- ⊙ EXISTING SANITARY MANHOLE
- ⊙ EXISTING WATER VALVE
- ⊙ EXISTING UTILITY POLE
- EXISTING FENCELINE
- EXISTING OVERHEAD WIRE
- EXISTING SANITARY SEWER LINE
- EXISTING WATER MAIN
- - - - - PROPOSED CONTOUR LINE
- ▬▬▬ PROPOSED CONCRETE CURB
- ▬▬▬ PROPOSED CONCRETE SIDEWALK
- ▬▬▬ PROPOSED SIGN
- ▬▬▬ PROPOSED RETAINING WALL

**SITE NOTES**

1. PROPERTY BOUNDARY, TOPOGRAPHY AND EXISTING UTILITY SHOWN HEREON ARE BASED ON A SURVEY ENTITLED "BOUNDARY & TOPOGRAPHIC SURVEY OF THE LANDS OF BANTA REALTY" PREPARED BY AUTOMATED CONSTRUCTION ENHANCED SOLUTIONS, INC., DATED MARCH 24, 2017.



now or formerly lands of  
Windsor Hospitality,  
Liber 13821 - Page 1  
Lot 2 - F.M. No. 283-03  
Tax ID: #4-1-68.2

now or formerly lands of  
J. Daskalis Family  
Limited Partnership  
Liber 5167 - Page 185  
Lot 1 - F.M. No. 283-03  
Tax ID: #4-1-67

**Town of New Windsor  
Planning Board Approval**

Tax Map Parcel No. 4-1-12.11 (2.81 Ac)

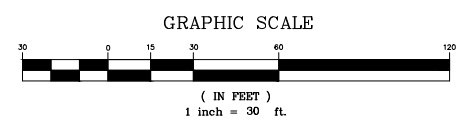
IT IS A VIOLATION OF NEW YORK STATE EDUCATION LAW FOR ANY PERSONS TO ALTER THESE PLANS, SPECIFICATIONS, OR REPORTS IN ANY WAY, UNLESS ACTING UNDER THE DIRECTION OF A LICENSED PROFESSIONAL ENGINEER OR LAND SURVEYOR.

Mark A. Day, PE	
Issue Date:	January 15, 2019
Project No.:	2016:003
License No.:	069646

**M.A. DAY Engineering, PC**  
Consulting Engineers  
3 Van Wyck  
Lane Suite 2  
Wappingers Falls, New York  
(845)-223-3202

**935 Union Ave**  
Town of New Windsor Orange County, NY

**Site Plan**



DATE:	04-07-17	DRAWN BY:	CJV	PROJECT NO.:	CS101
DATE:	04-07-17	DRAWN BY:	DJL	PROJECT NO.:	3 of 16



# Exhibit 4 - Landscaping Plan



L6 S 82°46'46" W  
L7 N 29°09'00" W

**LEGEND**

- EXISTING PROPERTY LINE
- - - - ADJACENT PROPERTY LINE (APPROX.)
- - - - EXISTING 10 FT CONTOUR LINE
- - - - EXISTING 2 FT CONTOUR LINE
- EXISTING TREE LINE
- EXISTING TREES
- EXISTING STONE WALL
- EXISTING FENCE
- EXISTING WATER
- EXISTING UNIMPROVED ROAD
- EXISTING UTILITY POLE
  
- PROPOSED LIMITS OF PROJECT
- PROPOSED CONCRETE CURB
- PROPOSED CONCRETE SIDEWALK
  
- PROPOSED BUILDING
- PROPOSED PARKING (PAVED)
- PROPOSED PARKING (LANDBANKED)
  
- PROPOSED SHRUBS
- PROPOSED TREES

now or formerly lands of  
Windsor Hospitality, LLC  
Liber 13821 - Page 1082  
Lot 2 - F.M. No. 283-03  
Tax ID: #4-1-68.2



**Tree Legend**

Symbol	Latin Name	Common Name	Plant Size	Condition	Quantity
ARO	Acer rubrum 'October Glory'	October Glory Maple	2 1/2" - 3" cal.	B&B	2
CFR	Cornus florida 'rubra'	Red Flowering Dogwood	6" - 8"	B&B	4
RS	Picea Rubens	Red Spruce	6'-8"	B&B	12

**Shrub Legend**

Symbol	Latin Name	Common Name	Plant Size	Condition	Quantity
MP	Myrica pensylvanica	Northern Bayberry	2 1/2'-3"	5 gal.	43
IGS	ilex gkabra 'shamrock'	Shamrock Inkberry	24"-30"	5 gal.	13
CSB	Cornus sericea 'Bailey'	Bailey's Red Twiggled Dogwood	2'-3"	5 gal.	31
CSF	Cornus sericea 'Flavirimea'	Goldflame Spirea	2'-3"	5 gal.	6

Town of New Windsor  
Planning Board Approval  
NWPB Project No. 17-04  
Tax Map Parcel No. 4-1-12.11 (2.81 Ac)

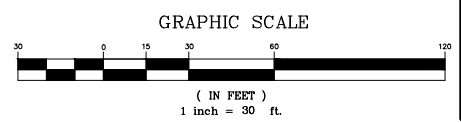
IT IS A VIOLATION OF NEW YORK STATE EDUCATION LAW FOR ANY PERSONS TO ALTER THESE PLANS, SPECIFICATIONS, OR REPORTS IN ANY WAY, UNLESS ACTING UNDER THE DIRECTION OF A LICENSED PROFESSIONAL ENGINEER OR LAND SURVEYOR.

Mark A. Day, PE  
  
 January 15, 2019  
 May 5, 2017  
 2016:003 License No. 069646

**M.A. DAY Engineering, PC**  
 Consulting Engineers  
 3 Van Wyck Lane Suite 2  
 Wappingers Falls, New York  
 (845)-223-3202

PROJECT: 935 Union Ave  
 Town of New Windsor Orange County, NY

**Landscaping Plan**  
 SCALE: 1" = 30'  
 DATE: 04-07-17  
 DRAWN BY: CJV  
 CHECKED BY: DJL  
**LP101**  
 11 of 16





# Exhibit 5 - Lighting Plan



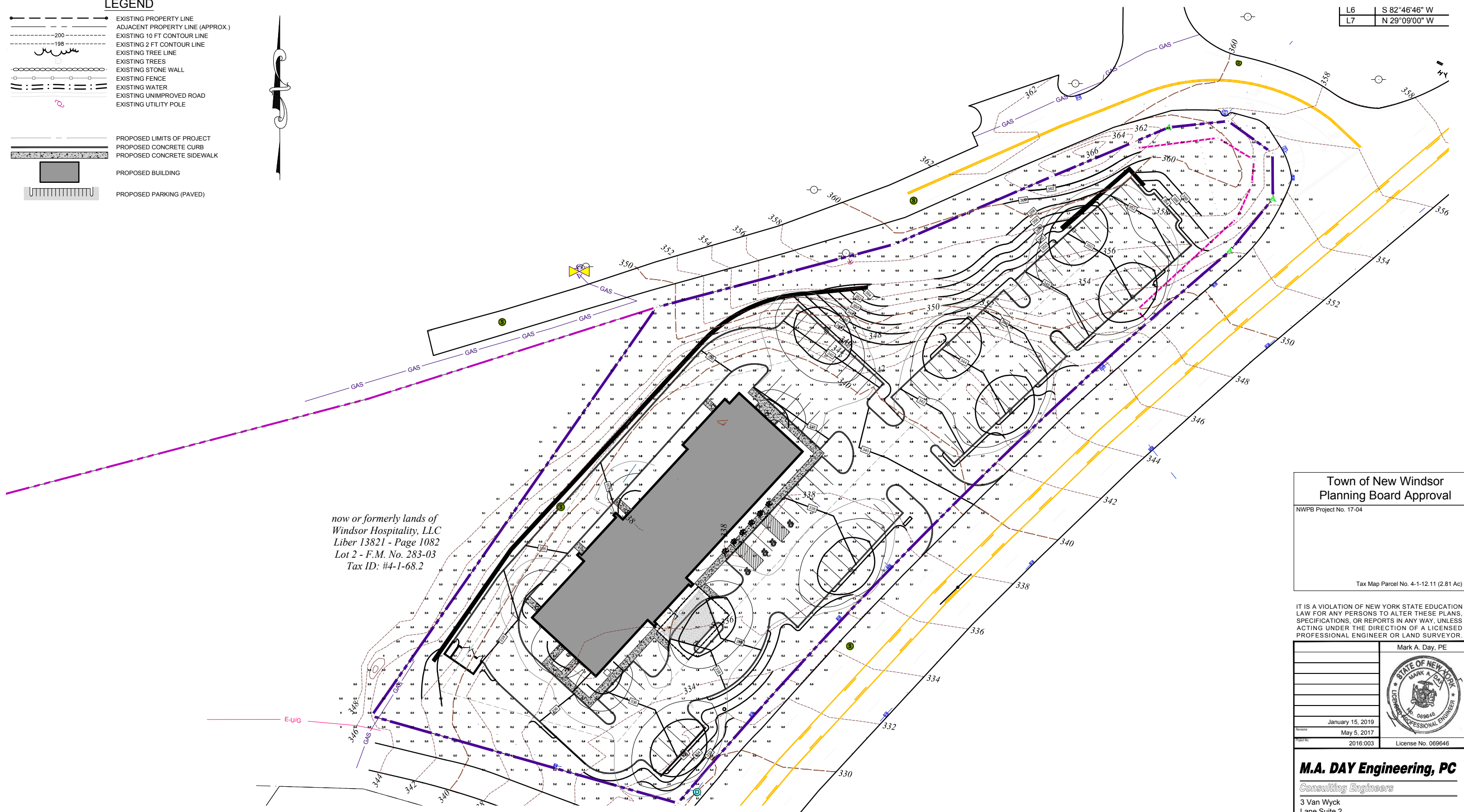


L6 S 82°46'46" W  
L7 N 29°09'00" W

**LEGEND**

- EXISTING PROPERTY LINE
- - - ADJACENT PROPERTY LINE (APPROX.)
- - - 100 EXISTING 10 FT CONTOUR LINE
- - - 200 EXISTING 2 FT CONTOUR LINE
- EXISTING TREE LINE
- EXISTING TREES
- EXISTING STONE WALL
- EXISTING FENCE
- EXISTING WATER
- EXISTING UNIMPROVED ROAD
- EXISTING UTILITY POLE
  
- PROPOSED LIMITS OF PROJECT
- PROPOSED CONCRETE CURB
- PROPOSED CONCRETE SIDEWALK
  
- PROPOSED BUILDING
- ▭ PROPOSED PARKING (PAVED)

now or formerly lands of  
Windsor Hospitality, LLC  
Liber 13821 - Page 1082  
Lot 2 - F.M. No. 283-03  
Tax ID: #4-1-68.2



**Town of New Windsor  
Planning Board Approval**  
NWPB Project No. 17-04  
  
Tax Map Parcel No. 4-1-12.11 (2.81 Ac)

IT IS A VIOLATION OF NEW YORK STATE EDUCATION LAW FOR ANY PERSONS TO ALTER THESE PLANS, SPECIFICATIONS, OR REPORTS IN ANY WAY, UNLESS ACTING UNDER THE DIRECTION OF A LICENSED PROFESSIONAL ENGINEER OR LAND SURVEYOR.

Mark A. Day, PE	
DATE	January 15, 2019
DATE	May 5, 2017
PROJECT NO.	2016.003
LICENSE NO.	License No. 069646

**M.A. DAY Engineering, PC**  
Consulting Engineers  
3 Van Wyck  
Lane Suite 2  
Wappingers Falls, New York  
(845)-223-3202

PROJECT  
**935 Union Ave**  
Town of New Windsor Orange County, NY  
DRAWING  
**Lighting Plan**  
SCALE  
1" = 30'  
DATE  
04-07-17  
DRAWN BY  
D.J.L.  
CHECKED BY  
D.J.L.  
**LL101**  
13 of 16

LUMINAIRE SCHEDULE											
CALLOUT	SYMBOL	LAMP	DESCRIPTION	BALLAST	MOUNTING	MODEL	VOLTS	NOTE 1	NOTE 2	NOTE 3	QUANTITY
A	○ □	(1)	XAL5220	ELECTRONIC	POLE - 18 FT	HOWARD LIGHTING PRODUCTS,	120V 1P 2W				7
B	□	(1) 250W NAVE OSRAM	"HID WALLPACK"	ELECTRONIC	WALL - 12FT	"OSSI/LUM650/9602 + 899", "WP200HPS250"	120V 1P 2W				7

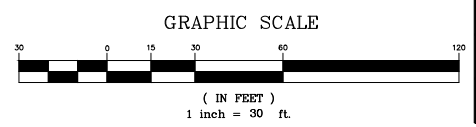




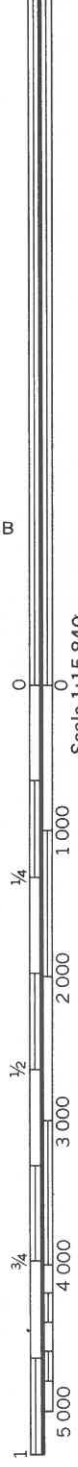
Exhibit 6 - Orange County Soil Survey – Sheet  
31







1 Mile  
5 000 Feet



560 000 FEET

545 000 FEET

(Joins sheet 30)

Wd Tg

MdB

(Joins sheet 42)

575 000 FEET

535 000 FEET

(Joins sheet 32)





# Exhibit 7 - Grading, Soil & Erosion Plan



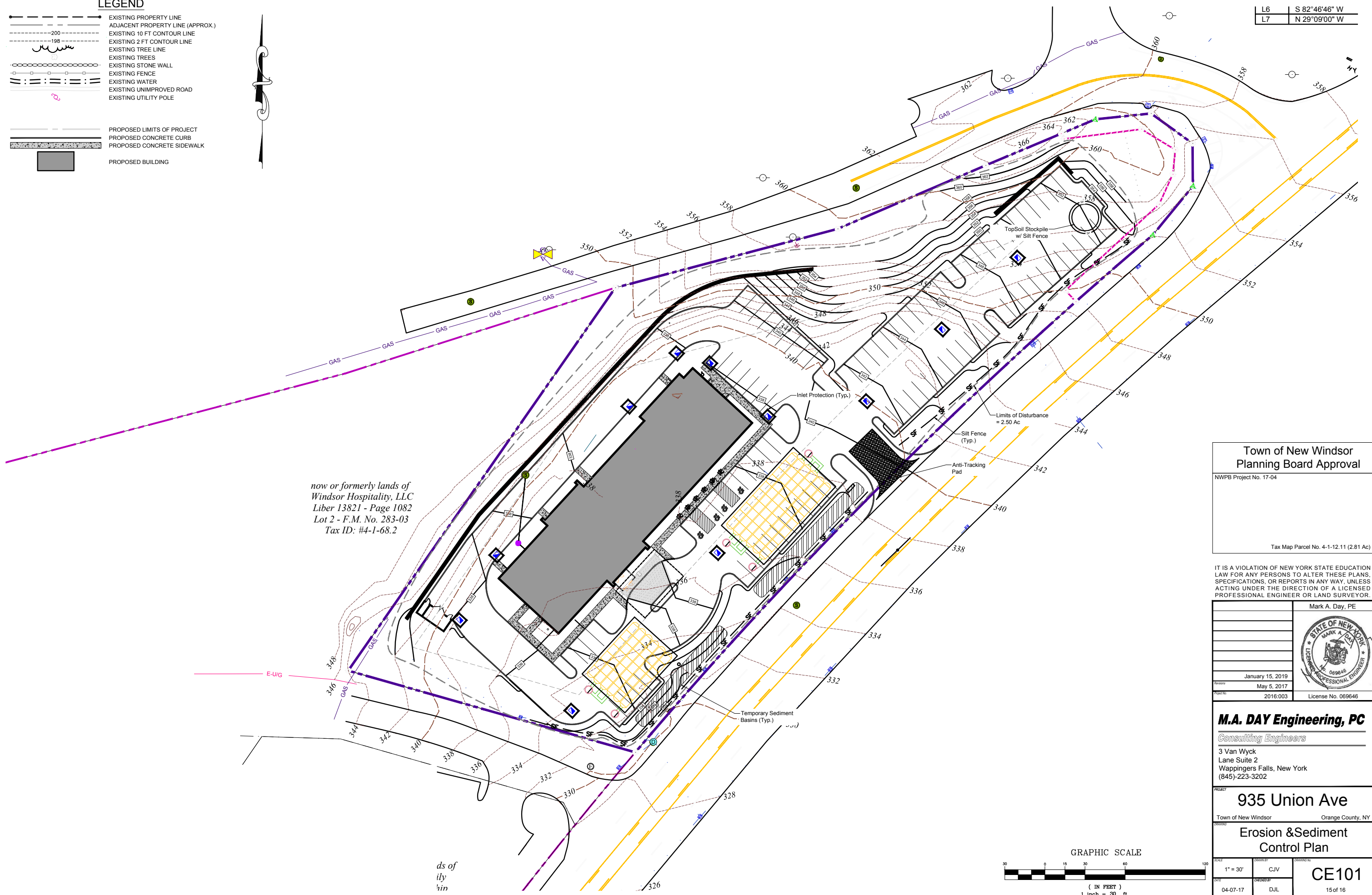


L6 S 82°46'46" W  
L7 N 29°09'00" W

**LEGEND**

- EXISTING PROPERTY LINE
- - - ADJACENT PROPERTY LINE (APPROX.)
- - - EXISTING 10 FT CONTOUR LINE
- - - EXISTING 2 FT CONTOUR LINE
- EXISTING TREE LINE
- EXISTING TREES
- EXISTING STONE WALL
- EXISTING FENCE
- EXISTING WATER
- EXISTING UNIMPROVED ROAD
- EXISTING UTILITY POLE
  
- PROPOSED LIMITS OF PROJECT
- PROPOSED CONCRETE CURB
- PROPOSED CONCRETE SIDEWALK
  
- PROPOSED BUILDING

now or formerly lands of  
Windsor Hospitality, LLC  
Liber 13821 - Page 1082  
Lot 2 - F.M. No. 283-03  
Tax ID: #4-1-68.2




**Town of New Windsor  
Planning Board Approval**

NWPB Project No. 17-04

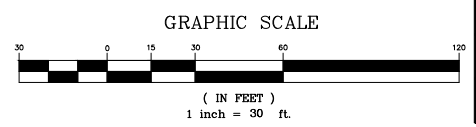
Tax Map Parcel No. 4-1-12.11 (2.81 Ac)

IT IS A VIOLATION OF NEW YORK STATE EDUCATION LAW FOR ANY PERSONS TO ALTER THESE PLANS, SPECIFICATIONS, OR REPORTS IN ANY WAY, UNLESS ACTING UNDER THE DIRECTION OF A LICENSED PROFESSIONAL ENGINEER OR LAND SURVEYOR.

	Mark A. Day, PE
	
January 15, 2019	
May 5, 2017	
2016.003	License No. 069646

**M.A. DAY Engineering, PC**  
Consulting Engineers  
3 Van Wyck Lane Suite 2  
Wappingers Falls, New York  
(845)-223-3202

<b>935 Union Ave</b>	
Town of New Windsor Orange County, NY	
<b>Erosion &amp; Sediment Control Plan</b>	
SCALE 1" = 30'	DRAWN BY CJV
DATE 04-07-17	CHECKED BY DJL
<b>CE101</b>	
15 of 16	





**SPDES GENERAL PERMIT GP-0-15-002 COMPLIANCE NOTES:**  
THE CONTRACTOR SHALL BE RESPONSIBLE FOR COMPLYING WITH THE FOLLOWING:

- THE CONTRACTOR AND HIS/HER SUBCONTRACTORS SHALL READ AND UNDERSTAND THE CONDITIONS OF THE "NYSDEC SPDES GENERAL PERMIT FOR STORM WATER DISCHARGES FROM CONSTRUCTION ACTIVITIES", GP-0-15-002 FOR THIS PROJECT.
- THE CONTRACTOR AND HIS/HER SUBCONTRACTORS SHALL SIGN A COPY OF THE GENERAL PERMIT, GP-0-15-002, CERTIFICATION STATEMENT AS IDENTIFIED IN THE APPENDICES OF THE STORMWATER POLLUTION PREVENTION PLAN (SWPPP).
- THE CONTRACTOR SHALL OBTAIN ALL REQUIRED PERMITS NECESSARY FOR THE WORK OUTLINED HEREIN.
- THE CONTRACTOR SHALL BE RESPONSIBLE FOR IMPLEMENTATION OF ALL STORMWATER POLLUTION PREVENTION MEASURES OUTLINED IN THE SWPPP AND PROJECT PLANS.
- THE CONTRACTOR SHALL HOLD A PRECONSTRUCTION CONFERENCE WITH THE OWNER'S REPRESENTATIVES AT LEAST ONE WEEK PRIOR TO COMMENCEMENT OF CONSTRUCTION.
- THE CONTRACTOR/OWNER SHALL HAVE A QUALIFIED PROFESSIONAL, AS DEFINED WITHIN THE NYSDEC SPDES GENERAL PERMIT GP-0-15-002, CONDUCT AN INITIAL SITE ASSESSMENT PRIOR TO CONSTRUCTION FOLLOWING THE COMMENCEMENT OF CONSTRUCTION AT LEAST EVERY 7 CALENDAR DAYS. REFER TO SWPPP FOR INSPECTION GUIDELINES.
- PRIOR TO COMMENCEMENT OF CONSTRUCTION, A QUALIFIED PROFESSIONAL (HIRED BY CONTRACTOR OR OWNER) SHALL CONDUCT AN ASSESSMENT OF THE SITE AND CERTIFY THAT THE APPROPRIATE EROSION AND SEDIMENT CONTROL STRUCTURES AS DEPICTED ON THE PLANS HAVE BEEN ADEQUATELY INSTALLED AND IMPLEMENTED. CONTRACTOR SHALL CONTACT THE PROJECT ENGINEER ONCE THE EROSION AND SEDIMENT CONTROL STRUCTURES HAVE BEEN INSTALLED. REFER TO SWPPP FOR INSPECTION GUIDELINES.
- THE OWNER/OPERATOR SHALL MAINTAIN A RECORD OF ALL EROSION AND SEDIMENT CONTROL INSPECTION REPORTS AT THE SITE IN A LOG BOOK. THE SITE LOG BOOK SHALL BE MAINTAINED ON-SITE AND BE MADE AVAILABLE TO THE PERMITTING AUTHORITY. THE OWNER/OPERATOR SHALL POST AT THE SITE, IN A PUBLICLY ACCESSIBLE LOCATION, A SUMMARY OF THE SITE INSPECTION ACTIVITIES ON A MONTHLY BASIS.
- THE OWNER/OPERATOR SHALL FILE A NOTICE OF INTENT (NOI) WITH THE NYSDEC AND LOCAL GOVERNING AUTHORITY PRIOR TO COMMENCING CONSTRUCTION ACTIVITIES AND A NOTICE OF TERMINATION (NOT) WITH NYSDEC FOLLOWING CONSTRUCTION ACTIVITIES.

**1 SPDES GENERAL PERMIT COMPLIANCE NOTES**  
NOT TO SCALE

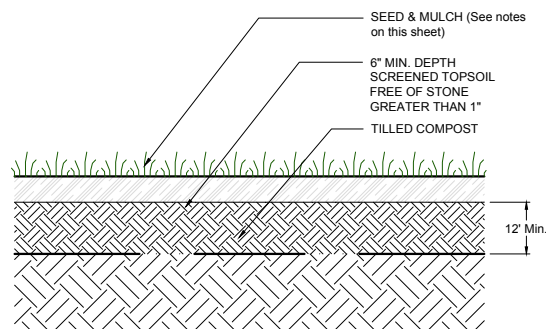
**EROSION AND SEDIMENT CONTROL MEASURES:**

- ALL EROSION AND SEDIMENT CONTROL MEASURES ARE TO BE IN STRICT COMPLIANCE WITH "NEW YORK STATE STANDARDS AND SPECIFICATIONS FOR EROSION AND SEDIMENT CONTROL", AUGUST 2005.
- DAMAGE TO SURFACE WATERS RESULTING FROM EROSION AND SEDIMENTATION SHALL BE MINIMIZED BY STABILIZING DISTURBED AREAS AND BY REMOVING SEDIMENT FROM CONSTRUCTION SITE DISCHARGES.
- AS MUCH AS IS PRACTICAL, EXISTING VEGETATION SHALL BE PRESERVED. FOLLOWING THE COMPLETION OF CONSTRUCTION ACTIVITIES IN ANY PORTION OF THE SITE, PERMANENT VEGETATION SHALL BE ESTABLISHED ON ALL EXPOSED SOILS.
- SITE PREPARATION ACTIVITIES SHALL BE PLANNED TO MINIMIZE THE SCOPE AND DURATION OF SOIL DISRUPTION.
- PERMANENT TRAFFIC CORRIDORS SHALL BE ESTABLISHED AND "ROUTES OF CONVENIENCE" SHALL BE AVOIDED. STABILIZED CONSTRUCTION ENTRANCES SHALL BE INSTALLED AT ALL POINTS OF ENTRY ONTO THE PROJECT SITE.
- SEEDED AREAS TO BE MULCHED WITH STRAW OR HAY MULCH IN ACCORDANCE WITH VEGETATIVE COVER SPECIFICATIONS.
- THE CONTRACTOR IS RESPONSIBLE FOR THE INSTALLATION AND MAINTENANCE OF ALL EROSION AND SEDIMENT CONTROL MEASURES THROUGHOUT THE COURSE OF CONSTRUCTION.
- THE CONTRACTOR IS RESPONSIBLE FOR CONTROLLING DUST BY SPRINKLING EXPOSED SOIL AREAS PERIODICALLY WITH WATER AS REQUIRED. THE CONTRACTOR IS TO SUPPLY ALL EQUIPMENT AND WATER.
- WHEN ALL DISTURBED AREAS ARE STABLE, ALL TEMPORARY EROSION AND SEDIMENT CONTROL MEASURES SHALL BE REMOVED.

**MAINTENANCE OF EROSION AND SEDIMENT CONTROL MEASURES:**

- PERMANENT AND TEMPORARY VEGETATION:**  
INSPECT ALL AREAS THAT HAVE RECEIVED VEGETATION EVERY SEVEN DAYS. ALL AREAS DAMAGED BY EROSION OR WHERE SEED HAS NOT ESTABLISHED SHALL BE REPAIRED AND REESTABLISHED IMMEDIATELY.
- STABILIZED CONSTRUCTION ENTRANCE:**  
INSPECT THE ENTRANCE PAD EVERY SEVEN DAYS. CHECK FOR MUD, SEDIMENT BUILD-UP AND PAD INTEGRITY. MAKE DAILY INSPECTIONS DURING WET WEATHER. RESHAPE PAD AS NEEDED FOR DRAINAGE AND RUNOFF CONTROL. WASH AND REPLACE STONE AS NEEDED. THE STONE IN THE ENTRANCE SHOULD BE WASHED OR REPLACED WHENEVER THE ENTRANCE FAILS TO REDUCE MUD BEING CARRIED OFF-SITE BY VEHICLES. IMMEDIATELY REMOVE MUD AND SEDIMENT TRACKED OR WASHED ONTO PUBLIC ROADS BY BRUSHING OR SWEEPING. REMOVE TEMPORARY CONSTRUCTION ENTRANCE AS SOON AS THEY ARE NO LONGER NEEDED TO PROVIDE ACCESS TO THE SITE.
- SILT FENCE:**  
INSPECT FOR DAMAGE EVERY SEVEN DAYS. MAKE ALL REPAIRS IMMEDIATELY. REMOVE SEDIMENT FROM THE UP-SLOPE FACE OF THE FENCE BEFORE IT ACCUMULATES TO A HEIGHT EQUAL TO 1/3 THE HEIGHT OF THE FENCE. IF FENCE FABRIC TEARS, BEGINS TO DECOMPOSE, OR IN ANY WAY BECOMES INEFFECTIVE, REPLACE THE AFFECTED SECTION OF FENCE IMMEDIATELY.
- SOIL STOCKPILE:**  
INSPECT SEDIMENT CONTROL BARRIERS (SILT FENCE OR HAY BALE) AND VEGETATION FOR DAMAGE EVERY SEVEN DAYS. MAKE ALL REPAIRS IMMEDIATELY. REMOVE SEDIMENT FROM THE UP-SLOPE FACE OF THE SEDIMENT CONTROL BARRIER BEFORE IT ACCUMULATES TO A HEIGHT EQUAL TO 1/3 THE HEIGHT OF THE SEDIMENT CONTROL BARRIER. IF SEDIMENT CONTROL BARRIER TEARS, BEGINS TO DECOMPOSE, OR IN ANYWAY BECOMES INEFFECTIVE, REPLACE THE AFFECTED SECTION OF SEDIMENT CONTROL BARRIER IMMEDIATELY. REVEGETATE DISTURBED AREA TO STABILIZE SOIL STOCK PILE. REMOVE THE SEDIMENT CONTROL BARRIER WHEN THE SOIL STOCKPILE HAS BEEN REMOVED.
- INLET PROTECTION:**  
INSPECT INLET PROTECTION FOR DAMAGE EVERY SEVEN DAYS. MAKE ALL REPAIRS IMMEDIATELY. REMOVE SEDIMENT AS NECESSARY TO PROVIDE FOR ADEQUATE STORAGE VOLUME FOR SUBSEQUENT RAINS.
- DUST CONTROL:**  
SCHEDULE CONSTRUCTION OPERATIONS TO MINIMIZE THE AMOUNT OF DISTURBED AREAS AT ANY ONE TIME DURING THE COURSE OF WORK. APPLY TEMPORARY SOIL STABILIZATION PRACTICES SUCH AS MULCHING, SEEDING, AND SPRAYING (WATER). STRUCTURAL MEASURES (MULCH, SEEDING) SHALL BE INSTALLED IN DISTURBED AREAS BEFORE SIGNIFICANT BLOWING PROBLEMS DEVELOP. WATER SHALL BE SPRAYED AS NEEDED, REPEAT AS NEEDED, BUT AVOID EXCESSIVE SPRAYING, WHICH COULD CREATE RUNOFF AND EROSION PROBLEMS.

**5 EROSION & SEDIMENT CONTROL NOTES**  
NOT TO SCALE



- DURING PERIODS OF RELATIVELY LOW MODERATE SUBSOIL MOISTURE, THE DISTURBED SUBSOILS ARE RETURNED TO ROUGH GRADE AND THE FOLLOWING SOIL RESTORATION STEPS APPLIED:
- APPLY 3 INCHES OF COMPOST OVER SUBSOIL
  - TILL COMPOST INTO SUBSOIL TO A DEPTH OF AT LEAST 12 INCHES USING A CAT-MOUNTED RIPPER, TRACTOR-MOUNTED DISC, OR TILLER, MIXING, AND CIRCULATING AIR AND COMPOST INTO SUBSOILS.
  - ROCK-PICK UNTIL UPLIFTED STONE/ROCK MATERIALS OF FOUR INCHES AND LARGER SIZE ARE CLEANED OF THE SITE.
  - APPLY TOPSOIL TO A DEPTH OF 6 INCHES.
  - VEGETATE AS REQUIRED BY APPROVED PLANS.

**9 SOIL RESTORATION DETAIL**  
NOT TO SCALE

**Construction Waste Management Plan**

Construction waste management practices are designed to maintain a clean and orderly work environment. This will reduce the potential for significant materials to come into contact with stormwater. A maintenance schedule shall be developed for these areas. The general contractor shall implement the following practices:

- Material resulting from the clearing and grubbing operation will be stockpiled up slope from adequate sedimentation controls.
- Equipment cleaning, maintenance, and repair areas shall be designated and protected by a temporary perimeter berm.
- The use of detergents for large scale washing is prohibited (i.e., vehicles, buildings, pavement surfaces, etc.).
- Spill Prevention and Response**  
A Spill Prevention and Response Plan shall be developed for the site by the general contractor. The plan shall detail the steps needed to be followed in the event of an accidental spill and shall identify contact names and phone numbers of people and agencies that must be notified.  
The plan shall include Material Safety Data Sheets (MSDS) for all materials to be stored on-site. All workers on-site will be required to be trained on safe handling and spill prevention procedures for all materials used during construction. Regular tailgate safety meetings shall be held and all workers that are expected on the site during the week shall be required to attend.
- Material Storage**  
Construction materials shall be stored in a dedicated staging area. The staging area shall be located in an area that minimizes the impacts of the construction materials effecting stormwater quality.  
Chemicals, paints, solvents, fertilizers, and other toxic material must be stored in waterproof containers. Except during application, the contents must be kept in trucks or within storage facilities. Runoff containing such material must be collected, removed from the site, treated and disposed at an approved solid waste or chemical disposal facility.
- Temporary Concrete Washout Facility**  
Temporary concrete washout facilities should be located a minimum of 50 ft from storm drain inlets, open drainage facilities, and watercourses. Each facility should be located away from construction traffic or access areas to prevent disturbance or tracking. A sign should be installed adjacent to each washout facility to inform concrete equipment operators to utilize the proper facilities.  
When temporary concrete washout facilities are no longer required for the work, the hardened concrete shall be removed and disposed of. Materials used to construct the temporary concrete washout facilities shall be removed from the site and disposed of. Holes, depressions or other ground disturbance caused by the removal of the temporary concrete washout facilities shall be backfilled and/or repaired and seeded and mulched for final stabilization.
- Soil Waste Disposal**  
No solid materials, including building materials, are allowed to be discharged from the site with stormwater. All solid waste, including disposable materials incidental to the major construction activities, must be collected and placed in containers. The containers will be emptied periodically by a contract trash disposal service and hauled away from the site.  
Substances that have the potential for polluting surface and/or groundwater must be controlled by whatever means necessary in order to ensure that they do not discharge from the site. As an example, special care must be exercised during equipment fueling and servicing operations. If a spill occurs, it must be contained and disposed so that it will not flow from the site or enter groundwater, even if this requires removal, treatment, and disposal of soil. In this regard, potentially polluting substances should be handled in a manner consistent with the impact they represent.
- Water Source**  
Non-stormwater components of site discharge must be clean water. Water used for construction, which discharges from the site, must originate from a public water supply or private well approved by the Health Department. Water used for construction that does not originate from an approved public supply must not discharge from the site. It can be retained in the ponds until it infiltrates and evaporates.

**2 CONSTRUCTION WASTE MANAGEMENT PLAN**  
NOT TO SCALE

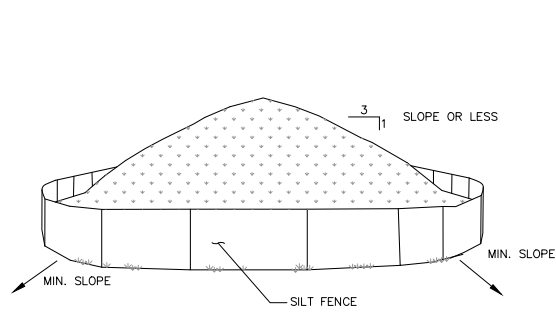
**PRE-CONSTRUCTION SEQUENCE:**

- Non-disturbance areas shall be marked with 4-ft orange snow fencing to Town Engineer's satisfaction prior to site disturbance, and shall be maintained until issuance of a c.o.
- Hold a pre-construction meeting with the owner/operator, site engineer, Town Engineer, trained contractor, qualified erosion control inspector and building inspector. Place a copy of the SWPPP report on site along with a copy of the inspector's log book containing copies of the weekly inspections. (applicant's erosion & sediment control inspection agent shall conduct an inspection on a weekly basis)

**3 CONSTRUCTION SEQUENCE:**

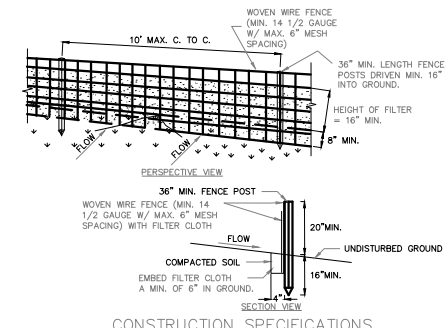
- Install and stabilize temporary erosion & sediment control measures as shown on the Erosion & Sediment Control plan.
- Install temporary diversion swales as necessary to divert runoff away from construction.
- Commence initial demolition of existing building.
- Begin remaining site grading, driveway grade construction and foundation excavation.
- Rough out driveway and parking area to sub-grade.
- Pour concrete footings and foundations for proposed buildings.
- Install remaining site utilities and/or infrastructure.
- Pave driveway and install curbing once all major work on site is complete, as required.
- Previous pavement practices should be installed toward the end of the construction period. Upstream construction shall be completed and stabilized before connection to porous pavement system. A dense and vigorous vegetative cover shall be established over any contributing pervious drainage areas before runoff can be accepted into the facility.
- Install on-pavement temporary inlet protection.
- Topsoil, seed and mulch all disturbed areas that have obtained finished grade elevations as per the soil restoration detail.
- Seed and mulch all disturbed areas that will not be re-disturbed for at least 14 days.
- Finalize building construction.
- Pave parking areas and drives with final top-coat of asphalt.
- Once all major site disturbance activities have ceased and the site has achieved final stabilization, file an N.O.T. (notice of termination) with NYSDEC.
- Terminate erosion control inspections.

**6 CONSTRUCTION SEQUENCE**  
NOT TO SCALE



- NOTES:**
- AREA CHOSEN FOR STOCKPILING OPERATIONS SHALL BE DRY AND STABLE.
  - MAXIMUM SLOPE OF STOCKPILE SHALL BE 1V:2H.
  - UPON COMPLETION OF SOIL STOCKPILING, EACH PILE SHALL BE SURROUNDED WITH SILT FENCING, THEN STABILIZED WITH VEGETATION OR COVERED.
  - SEE SPECIFICATIONS FOR INSTALLATION OF SILT FENCE.
  - HAYBALES TO BE USED WHERE STOCKPILES ARE LOCATED ON PAVED AREAS.

**10 TEMPORARY SOIL STOCKPILE DETAIL**  
NOT TO SCALE



- CONSTRUCTION SPECIFICATIONS**
- WOVEN WIRE FENCE TO BE FASTENED SECURELY TO FENCE POSTS WITH WIRE TIES OR STAPLES. POSTS SHALL BE STEEL EITHER "T" OR "U" TYPE OR HARDWOOD.
  - FILTER CLOTH TO BE FASTENED SECURELY TO WOVEN WIRE FENCE WITH TIES SPACED EVERY 24" AT TOP AND MID SECTION. FENCE SHALL BE WOVEN WIRE, 1/2 GAUGE, 6" MAXIMUM MESH OPENING.
  - WHEN TWO SECTIONS OF FILTER CLOTH ADJOIN EACH OTHER THEY SHALL BE OVERLAPPED BY SIX INCHES AND FOLDED. FILTER CLOTH SHALL BE EITHER FILTER X, MARY HOOK, STABILINK T-100, OR APPROVED EQUIVALENT.
  - PREFABRICATED UNITS SHALL BE GEOTAB, ENVIROFENCE, OR APPROVED EQUIVALENT.
  - MAINTENANCE SHALL BE PERFORMED AS NEEDED AND MATERIAL REMOVED WHEN "BULGES" DEVELOP IN THE SILT FENCE.

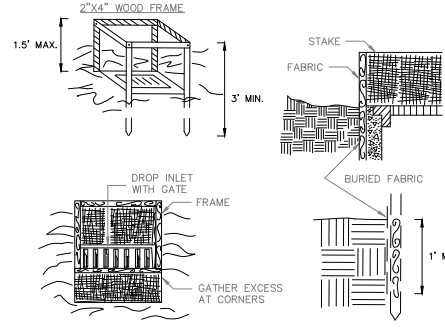
**3 SILT FENCE DETAIL**  
NOT TO SCALE

- ALL SEDIMENT & EROSION CONTROL MEASURES SHALL BE INSTALLED IN ACCORDANCE WITH THESE PLANS & DETAILS. CHANGES, OMISSIONS AND/OR OTHER ALTERATIONS CAN NOT BE MADE TO THESE PLANS WITHOUT THE CONSENT OF THE DESIGN ENGINEER.
- SILT FENCE SHALL BE INSTALLED AS SHOWN ON THIS DRAWING PRIOR TO BEGINNING ANY CLEARING, GRUBBING AND EARTHWORK.
- EXPOSED SLOPES AND ALL GRADED AREAS SHALL BE SEEDED WITH THE FOLLOWING GRASS SEED MIX IMMEDIATELY UPON COMPLETION OF ITS CONSTRUCTION, OR IF PLANNED TO BE LEFT UNDISTURBED FOR MORE THAN 21 DAYS. GRASS SEED MIX TO BE APPLIED AT A RATE OF 50 POUNDS PER ACRE IN THE FOLLOWING PROPORTIONS:

KENTUCKY BLUEGRASS	40%
CREeping RED FESCUE	40%
RYE GRASS	20%

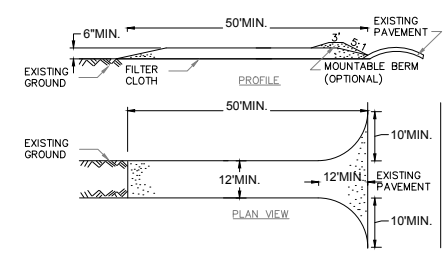
- GRASS SEED MIX MAY BE APPLIED BY EITHER MECHANICAL OR HYDROSEEDING METHODS. HYDROSEEDING SHALL BE PERFORMED IN ACCORDANCE WITH THE CURRENT EDITION OF THE NYSDOT STANDARD SPECIFICATIONS, CONSTRUCTION AND MATERIALS, SECTION 610-3.02, METHOD No. 1.
- SEEDING AREAS SHALL BE MULCHED WITH STRAW AT A RATE OF 2 TONS PER ACRE OR 90 LBS. PER 1,000 SQUARE FEET, SUCH THAT IT FORMS A CONTINUOUS BLANKET.
- SEDIMENTATION AND EROSION CONTROL MEASURES SHALL BE INSPECTED AND MAINTAINED ON A DAILY BASIS BY THE OWNER'S FIELD REPRESENTATIVE.
- DUST SHALL BE CONTROLLED BY SPRINKLING OF WATER OR OTHER APPROVED METHODS AS NECESSARY AS DIRECTED BY THE OWNER'S FIELD REPRESENTATIVE.
- CUTS AND FILLS SHALL NOT ENDANGER ADJOINING PROPERTY, NOR DIVERT SURFACE WATER ONTO ADJOINING PROPERTIES.
- ALL FILLS SHALL BE COMPACTED TO PROVIDE STABILITY OF MATERIALS AND TO PREVENT SETTLEMENT.
- EXCAVATIONS AND FILLS TO BE ROLLED, SEALED AND STABILIZED AT COMPLETION OF EACH DAY'S WORK.
- THE OWNER'S FIELD REPRESENTATIVE SHALL INSPECT THE DOWNSTREAM CONDITIONS FOR EVIDENCE OF SEDIMENTATION ON A WEEKLY BASIS AND AFTER RAINSTORMS.
- AS WARRANTED BY FIELD CONDITIONS, SPECIAL ADDITIONAL SEDIMENTATION AND EROSION CONTROL MEASURES MAY BE ADDED TO THIS PLAN BY THE SITE ENGINEER, TOWN ENGINEER AND HIGHWAY SUPERINTENDENT. ANY REVISIONS TO THIS PLAN MUST BE SUBMITTED TO THE SITE ENGINEER. ANY CHANGES DEEMED NECESSARY TO THIS PLAN SHALL BE DICTATED BY THE SITE ENGINEER AS NECESSARY TO CARRY-OUT THE INTENT OF THIS PLAN.

**7 SEEDING & MULCHING NOTES**  
NOT TO SCALE



- CONSTRUCTION SPECIFICATIONS**
- FILTER FABRIC SHALL HAVE AN EOS OF 40-85. BURLAP MAY BE USED FOR SHORT TERM APPLICATIONS.
  - CUT FABRIC FROM A CONTINUOUS ROLL TO ELIMINATE JOINTS. IF JOINTS ARE NEEDED THEY WILL BE OVERLAPPED TO THE NEXT STAKE.
  - STAKE MATERIALS WILL BE STANDARD 2" x 4" WOOD OR EQUIVALENT. METAL WITH A MINIMUM LENGTH OF 3 FEET.
  - SPACE STAKES EVENLY AROUND INLET 3 FEET APART AND DRIVE A MINIMUM 18 INCHES DEEP. SPACES GREATER THAN 3 FEET MUST BE BRIDGED WITH THE USE OF WIRE MESH BEHIND THE FILTER FABRIC FOR SUPPORT.
  - FABRIC SHALL BE EMBEDDED 1 FOOT MINIMUM BELOW GROUND AND BACKFILLED. IT SHALL BE SECURELY FASTENED TO THE STAKES AND FRAME.
  - 2" x 4" WOOD FRAME SHALL BE COMPLETED AROUND THE CREST OF THE FABRIC FOR OVER FLOW STABILITY. MAXIMUM DRAINAGE AREA 1 ACRE

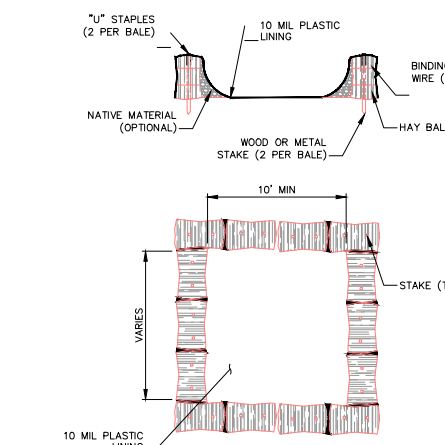
**11 FILTER FABRIC DROP INLET PROTECTION**  
NOT TO SCALE



**CONSTRUCTION SPECIFICATIONS**

- STONE SIZE - USE 1-4 INCH STONE, OR RECLAIMED OR RECYCLED CONCRETE EQUIVALENT.
- LENGTH - NOT LESS THAN 50 FEET (EXCEPT ON A SINGLE RESIDENCE LOT WHERE A 30 FOOT MINIMUM LENGTH WOULD APPLY).
- THICKNESS - NOT LESS THAN SIX (6) INCHES.
- WIDTH - TWELVE (12) FOOT MINIMUM, BUT NOT LESS THAN THE FULL WIDTH AT POINTS WHERE INGRESS OR EGRESS OCCURS. TWENTY-FOUR (24) FOOT IF SINGLE ENTRANCE TO SITE.
- GEOTEXTILE - WILL BE PLACED OVER THE ENTIRE AREA PRIOR TO PLACING OF STONE.
- SURFACE WATER - ALL SURFACE WATER FLOWING OR DIVERTED TOWARD CONSTRUCTION ACCESS SHALL BE PIPED BENEATH THE ENTRANCE. IF PIPING IS IMPRACTICAL, A MOUNTABLE BERM WITH 5:1 SLOPES WILL BE PERMITTED.
- MAINTENANCE - THE ENTRANCE SHALL BE MAINTAINED IN A CONDITION WHICH WILL PREVENT TRACKING OR FLOWING OF SEDIMENT ONTO PUBLIC RIGHTS-OF-WAY, ALL SEDIMENT SPILLED, DROPPED, WASHED OR TRACKED ONTO PUBLIC RIGHTS-OF-WAY MUST BE REMOVED IMMEDIATELY.
- WHEN WASHING IS REQUIRED, IT SHALL BE DONE ON A AREA STABILIZED WITH STONE AND WHICH DRAINS INTO AN APPROVED SEDIMENT TRAPPING DEVICE.
- PERIODIC INSPECTION AND NEEDED MAINTENANCE SHALL BE PROVIDED AFTER EACH RAIN.

**4 ANTI-TRACKING PAD DETAIL**  
NOT TO SCALE



- NOTES:**
- CONCRETE WASHOUT SIGN TO BE INSTALLED WITHIN 30 FEET OF THE TEMPORARY CONCRETE WASHOUT FACILITY.
  - REMOVE HARDEN CONCRETE WHEN WITHIN 4" FROM TOP OF STRUCTURE.
  - CONSTRUCT NEW FACILITIES ONCE CURRENT FACILITIES ARE TWO-THIRDS FULL.
  - LINERS, HAYBALES, ETC SHALL BE INSPECTED FOR DAMAGE. ANY DAMAGE SHALL BE REPAIR PROMPTLY.

**8 TEMPORARY CONCRETE WASHOUT DETAIL**  
NOT TO SCALE

**Town of New Windsor  
Planning Board Approval**

NWPB Project No. 17-04

Tax Map Parcel No. 4-1-12.11 (2.81 Ac)

IT IS A VIOLATION OF NEW YORK STATE EDUCATION LAW FOR ANY PERSONS TO ALTER THESE PLANS, SPECIFICATIONS, OR REPORTS IN ANY WAY, UNLESS ACTING UNDER THE DIRECTION OF A LICENSED PROFESSIONAL ENGINEER OR LAND SURVEYOR.

Mark A. Day, PE	
January 15, 2019	
May 5, 2017	
Project No. 2016.003	License No. 069646

**M.A. DAY Engineering, PC**  
*Consulting Engineers*

3 Van Wyck  
Lane Suite 2  
Wappingers Falls, New York  
(845)-223-3202

**935 Union Ave**

Town of New Windsor      Orange County, NY

**Erosion & Sediment  
Control Details**

SCALE	DATE	DESIGNED BY	CE501
As Noted	04-07-17	D.J.L.	16 of 16

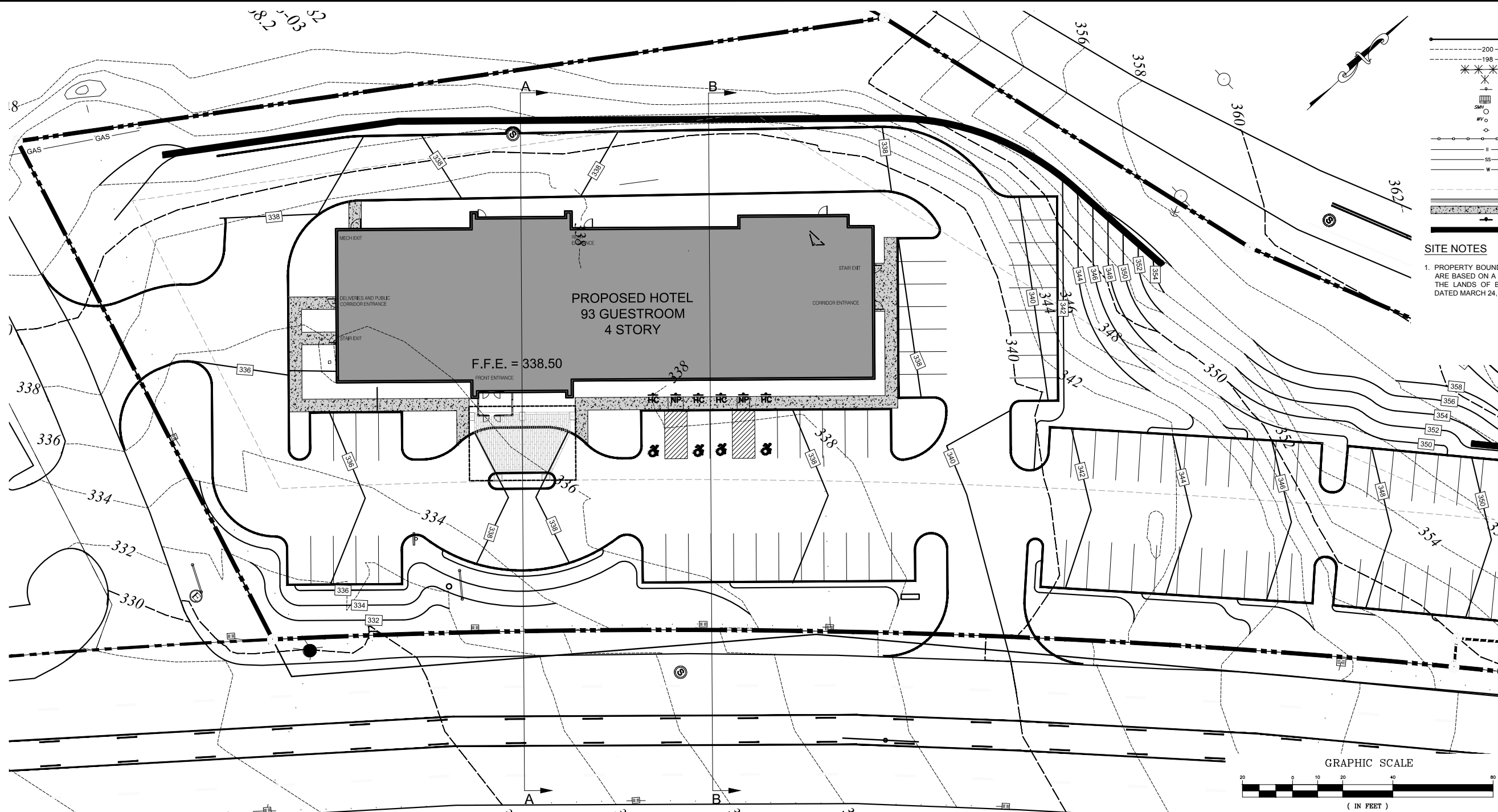


# Exhibit 8 - Section thru Property and Building





18.5.03.15



- LEGEND**
- EXISTING PROPERTY LINE
  - - - - - EXISTING 10 FT CONTOUR LINE
  - - - - - EXISTING 2 FT CONTOUR LINE
  - \* \* \* \* \* EXISTING TREE LINE
  - ⊗ EXISTING TREES
  - ⊕ EXISTING SIGN
  - ⊕ EXISTING CATCH BASIN
  - ⊕ EXISTING SANITARY MANHOLE
  - ⊕ EXISTING WATER VALVE
  - ⊕ EXISTING UTILITY POLE
  - EXISTING FENCELINE
  - EXISTING OVERHEAD WIRE
  - EXISTING SANITARY SEWER LINE
  - EXISTING WATER MAIN
  - - - - - PROPOSED CONTOUR LINE
  - ▬ PROPOSED CONCRETE CURB
  - ▬ PROPOSED CONCRETE SIDEWALK
  - ▬ PROPOSED SIGN
  - ▬ PROPOSED RETAINING WALL

**SITE NOTES**

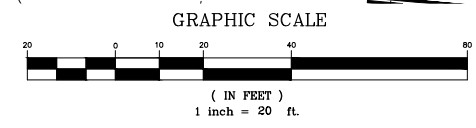
1. PROPERTY BOUNDARY, TOPOGRAPHY AND EXISTING UTILITY SHOWN HEREON ARE BASED ON A SURVEY ENTITLED "BOUNDARY & TOPOGRAPHIC SURVEY OF THE LANDS OF BANTA REALTY" PREPARED BY JONATHAN N MILLEN, L.L.S., DATED MARCH 24, 2017.

**Town of New Windsor  
Planning Board Approval**

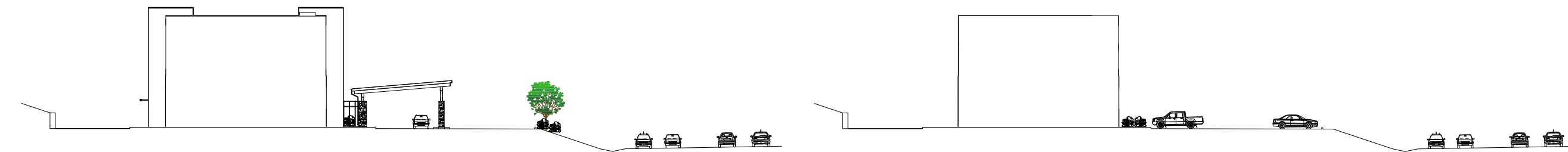
NWPB Project No. 17-04

Tax Map Parcel No. 4-1-12.11 (2.81 Ac)

IT IS A VIOLATION OF NEW YORK STATE EDUCATION LAW FOR ANY PERSONS TO ALTER THESE PLANS, SPECIFICATIONS, OR REPORTS IN ANY WAY, UNLESS ACTING UNDER THE DIRECTION OF A LICENSED PROFESSIONAL ENGINEER OR LAND SURVEYOR.



**SITE GRADING PLAN**  
Scale: 1" = 20'



**SECTION A-A**  
Scale: 1" = 20'

**SECTION B-B**  
Scale: 1" = 20'

Mark A. Day, PE	
Project: 2016:003 License No. 069646	
<b>M.A. DAY Engineering, PC</b>	
<i>Consulting Engineers</i>	
3 Van Wyck Lane Suite 2 Wappingers Falls, New York (845)-223-3202	
<b>935 Union Ave</b>	
Town of New Windsor Orange County, NY	
<b>Sections Thru Building &amp; Property</b>	
SCALE: 1" = 20'	DRAWN BY: D.J.L.
DATE: 06/25/18	CHECKED BY: MAD
<b>FG101</b>	
1 of 1	





## **D. Correspondence**

- U.S. Department of the Interior U.S. Fish & Wildlife Service – April 14, 2018
- N.Y.S. Department of Environmental Conservation – May 3, 2018
- Mr. Todd Wiley – Email from June 21, 2018
- Emergency Response Calls – January, 2000 – June, 2018



U.S. Department of the Interior U.S. Fish &  
Wildlife Service - April 14, 2018





## United States Department of the Interior



FISH AND WILDLIFE SERVICE  
New York Ecological Services Field Office  
3817 Luker Road  
Cortland, NY 13045-9385

Phone: (607) 753-9334 Fax: (607) 753-9699

<http://www.fws.gov/northeast/nyfo/es/section7.htm>

In Reply Refer To:

April 14, 2018

Consultation Code: 05E1NY00-2018-SLI-1763

Event Code: 05E1NY00-2018-E-05380

Project Name: 935 Union Avenue - Hotel

Subject: List of threatened and endangered species that may occur in your proposed project location, and/or may be affected by your proposed project

To Whom It May Concern:

The enclosed species list identifies threatened, endangered, proposed and candidate species, as well as proposed and final designated critical habitat, that may occur within the boundary of your proposed project and/or may be affected by your proposed project. The species list fulfills the requirements of the U.S. Fish and Wildlife Service (Service) under section 7(c) of the Endangered Species Act (ESA) of 1973, as amended (16 U.S.C. 1531 *et seq.*). This list can also be used to determine whether listed species may be present for projects without federal agency involvement. New information based on updated surveys, changes in the abundance and distribution of species, changed habitat conditions, or other factors could change this list.

Please feel free to contact us if you need more current information or assistance regarding the potential impacts to federally proposed, listed, and candidate species and federally designated and proposed critical habitat. Please note that under 50 CFR 402.12(e) of the regulations implementing section 7 of the ESA, the accuracy of this species list should be verified after 90 days. This verification can be completed formally or informally as desired. The Service recommends that verification be completed by visiting the ECOS-IPaC site at regular intervals during project planning and implementation for updates to species lists and information. An updated list may be requested through the ECOS-IPaC system by completing the same process used to receive the enclosed list. If listed, proposed, or candidate species were identified as potentially occurring in the project area, coordination with our office is encouraged. Information on the steps involved with assessing potential impacts from projects can be found at: <http://www.fws.gov/northeast/nyfo/es/section7.htm>

Please be aware that bald and golden eagles are protected under the Bald and Golden Eagle Protection Act (16 U.S.C. 668 *et seq.*), and projects affecting these species may require development of an eagle conservation plan (<http://www.fws.gov/windenergy/>)

[eagle\\_guidance.html](#)). Additionally, wind energy projects should follow the Services wind energy guidelines (<http://www.fws.gov/windenergy/>) for minimizing impacts to migratory birds and bats.

Guidance for minimizing impacts to migratory birds for projects including communications towers (e.g., cellular, digital television, radio, and emergency broadcast) can be found at: <http://www.fws.gov/migratorybirds/CurrentBirdIssues/Hazards/towers/towers.htm>; <http://www.towerkill.com>; and <http://www.fws.gov/migratorybirds/CurrentBirdIssues/Hazards/towers/comtow.html>.

We appreciate your concern for threatened and endangered species. The Service encourages Federal agencies to include conservation of threatened and endangered species into their project planning to further the purposes of the ESA. Please include the Consultation Tracking Number in the header of this letter with any request for consultation or correspondence about your project that you submit to our office.

Attachment(s):

- Official Species List

## Official Species List

This list is provided pursuant to Section 7 of the Endangered Species Act, and fulfills the requirement for Federal agencies to "request of the Secretary of the Interior information whether any species which is listed or proposed to be listed may be present in the area of a proposed action".

This species list is provided by:

**New York Ecological Services Field Office**

3817 Luker Road

Cortland, NY 13045-9385

(607) 753-9334

---

## Project Summary

Consultation Code: 05E1NY00-2018-SLI-1763

Event Code: 05E1NY00-2018-E-05380

Project Name: 935 Union Avenue - Hotel

Project Type: DEVELOPMENT

Project Description: Parking expansion for existing hotel

Project Location:

Approximate location of the project can be viewed in Google Maps: <https://www.google.com/maps/place/41.494250444943404N74.07533953377754W>



Counties: Orange, NY

---



## Endangered Species Act Species

There is a total of 5 threatened, endangered, or candidate species on this species list.

Species on this list should be considered in an effects analysis for your project and could include species that exist in another geographic area. For example, certain fish may appear on the species list because a project could affect downstream species.

IPaC does not display listed species or critical habitats under the sole jurisdiction of NOAA Fisheries<sup>1</sup>, as USFWS does not have the authority to speak on behalf of NOAA and the Department of Commerce.

See the "Critical habitats" section below for those critical habitats that lie wholly or partially within your project area under this office's jurisdiction. Please contact the designated FWS office if you have questions.

- 
1. [NOAA Fisheries](#), also known as the National Marine Fisheries Service (NMFS), is an office of the National Oceanic and Atmospheric Administration within the Department of Commerce.

## Mammals

NAME	STATUS
Indiana Bat <i>Myotis sodalis</i> There is <b>final</b> critical habitat for this species. Your location is outside the critical habitat. Species profile: <a href="https://ecos.fws.gov/ecp/species/5949">https://ecos.fws.gov/ecp/species/5949</a>	Endangered
Northern Long-eared Bat <i>Myotis septentrionalis</i> No critical habitat has been designated for this species. Species profile: <a href="https://ecos.fws.gov/ecp/species/9045">https://ecos.fws.gov/ecp/species/9045</a>	Threatened

## Reptiles

NAME	STATUS
Bog Turtle <i>Clemmys muhlenbergii</i> Population: Wherever found, except GA, NC, SC, TN, VA No critical habitat has been designated for this species. Species profile: <a href="https://ecos.fws.gov/ecp/species/6962">https://ecos.fws.gov/ecp/species/6962</a> Species survey guidelines: <a href="https://ecos.fws.gov/ipac/guideline/survey/population/182/office/52410.pdf">https://ecos.fws.gov/ipac/guideline/survey/population/182/office/52410.pdf</a> Habitat assessment guidelines: <a href="https://ecos.fws.gov/ipac/guideline/assessment/population/182/office/52410.pdf">https://ecos.fws.gov/ipac/guideline/assessment/population/182/office/52410.pdf</a>	Threatened

---

## Clams

NAME	STATUS
Dwarf Wedgemussel <i>Alasmidonta heterodon</i> No critical habitat has been designated for this species. Species profile: <a href="https://ecos.fws.gov/ecp/species/784">https://ecos.fws.gov/ecp/species/784</a> Species survey guidelines: <a href="https://ecos.fws.gov/ipac/guideline/survey/population/363/office/52410.pdf">https://ecos.fws.gov/ipac/guideline/survey/population/363/office/52410.pdf</a>	Endangered

## Flowering Plants

NAME	STATUS
Small Whorled Pogonia <i>Isotria medeoloides</i> No critical habitat has been designated for this species. Species profile: <a href="https://ecos.fws.gov/ecp/species/1890">https://ecos.fws.gov/ecp/species/1890</a> Species survey guidelines: <a href="https://ecos.fws.gov/ipac/guideline/survey/population/742/office/52410.pdf">https://ecos.fws.gov/ipac/guideline/survey/population/742/office/52410.pdf</a>	Threatened

## Critical habitats

THERE ARE NO CRITICAL HABITATS WITHIN YOUR PROJECT AREA UNDER THIS OFFICE'S JURISDICTION.

---

NYSDEC – May 3, 2018



# NEW YORK STATE DEPARTMENT OF ENVIRONMENTAL CONSERVATION

Division of Fish and Wildlife, New York Natural Heritage Program  
625 Broadway, Fifth Floor, Albany, NY 12233-4757  
P: (518) 402-8935 | F: (518) 402-8925  
www.dec.ny.gov

May 3, 2018

Michael Nowicki  
Ecological Solutions, LLC  
1248 Southford Road  
Southbury, CT 06488

Re: 935 Union Avenue - Hotel  
County: Orange Town/City: New Windsor

Dear Mr. Nowicki:

In response to your recent request, we have reviewed the New York Natural Heritage Program database with respect to the above project.

Enclosed is a report of rare or state-listed animals and plants, and significant natural communities that our database indicates occur in the vicinity of the project site. Given the location and nature of the proposed work, significant impacts on these species may not be expected. However, an official determination regarding any permit considerations for the project should be obtained from the Permits staff at the NYSDEC Region 3 Office; please contact them at [dep.r3@dec.ny.gov](mailto:dep.r3@dec.ny.gov), (845) 256-3054.

For most sites, comprehensive field surveys have not been conducted; the enclosed report only includes records from our database. We cannot provide a definitive statement as to the presence or absence of all rare or state-listed species or significant natural communities. Depending on the nature of the project and the conditions at the project site, further information from on-site surveys or other sources may be required to fully assess impacts on biological resources.

The presence of the plants and animals identified in the enclosed report may result in this project requiring additional review or permit conditions. For further guidance, and for information regarding other permits that may be required under state law for regulated areas or activities (e.g., regulated wetlands), please contact the NYS DEC Region 3 Office, Division of Environmental Permits, as described above.

Sincerely,



Nicholas Conrad  
Information Resources Coordinator  
New York Natural Heritage Program





**The following state-listed animals have been documented in the vicinity of the project site.**

The following list includes animals that are listed by NYS as Endangered, Threatened, or Special Concern; and/or that are federally listed or are candidates for federal listing.

**For information about any permit considerations for the project, please contact the Permits staff at the NYSDEC Region 3 Office at [dep.r3@dec.ny.gov](mailto:dep.r3@dec.ny.gov), (845) 256-3054. For information about potential impacts of the project on these species, and how to avoid, minimize, or mitigate any impacts, contact the Region 3 Wildlife staff at [Wildlife.R3@dec.ny.gov](mailto:Wildlife.R3@dec.ny.gov), (845) 256-3098.**

**The following species have been documented about .5 mile from the project site.**

<i>COMMON NAME</i>	<i>SCIENTIFIC NAME</i>	<i>NY STATE LISTING</i>	<i>FEDERAL LISTING</i>
<b>Upland Sandpiper</b> <i>Breeding</i>	<i>Bartramia longicauda</i>	Threatened	7655

**The following species have been documented about two miles from the project site. Individual animals may travel 2.5 miles from documented locations.**

**The main concern for bats is the removal or cutting of potential roost trees.**

<i>COMMON NAME</i>	<i>SCIENTIFIC NAME</i>	<i>NY STATE LISTING</i>	<i>FEDERAL LISTING</i>
<b>Indiana Bat</b> <i>Non-winter location</i>	<i>Myotis sodalis</i>	Endangered	Endangered 13890

This report only includes records from the NY Natural Heritage database.

If any rare plants or animals are documented during site visits, we request that information on the observations be provided to the New York Natural Heritage Program so that we may update our database.

Information about many of the listed animals in New York, including habitat, biology, identification, conservation, and management, are available online in Natural Heritage’s Conservation Guides at [www.guides.nynhp.org](http://www.guides.nynhp.org), and from NYSDEC at [www.dec.ny.gov/animals/7494.html](http://www.dec.ny.gov/animals/7494.html).





Mr. Todd Wiley Email – June 21, 2018



**From:** Todd Wiley  
**To:** [Mark Day](#)  
**Subject:** RE: Holiday Inn Express - Fiscal Impact Analysis  
**Date:** Thursday, June 21, 2018 1:29:59 PM  
**Attachments:** [image001.png](#)  
[Assessment Data.pdf](#)

---

Mr. Day,

In response to your request for information on the property known as 935 Union Avenue, and further identified as S-B-L 4-1-12.11 the following information is provided:

1. Based on a 93 unit limited service hotel, a Holiday Inn Express, and based on the current equalization rate of 16.75% and the current tax rates, if this hotel was completed and fully taxable today, with no exemptions, it would have a total assessed value of \$1,635,637 which equates to a market value of \$9,765,000. The total annual taxes would be \$339,848 and includes the town, county and school taxes. This figure is an estimate only. This project appears eligible for a 485-b Business partial exemption. As we discussed, this would exempt the increase in taxes by 50% for the first year, and the exemption declines 5% a year, over 10 years.
2. The total number of parcels in the Town is currently 9,952 parcels. See attached file. I do not have a breakdown of the residential and the commercial/industrial mix, nor would it be appropriate for me to take the time to calculate these amounts. We are not required to create data, only to provide what is already available.  
However, the attached file on Page 3 is a Town wide listing of all property types and the affiliated number of parcels per property type, as well as taxable assessed values for each property type. You can compile the data as you need to.  
The Property Type on this report is a 3 digit code that is known as the Property Class Code. For example- A code of 100 is an agricultural property type. 105 is vacant farm land, etc.  
You can look at a detailed listing of the Property Class Codes and the definition of each property type on the State's website at [www.tax.ny.gov](http://www.tax.ny.gov)  
I suggest that you use the site's internal search engine for "Property class codes" to quickly locate this info.  
The attached file also includes the taxable assessed value of each property type within the town. The amounts are shown as taxable assessed values and to convert any of these numbers to market value you would divide it by the current equalization rate of 16.75%.
3. Regarding item 3 of your request, as per Page 1 of the attachment, the current total assessed value of the Town is \$499,369,352 which equates to a total market value of \$2,981,308,042. These figures are for all properties, taxable and tax exempt.  
The total **taxable** assessed value of the properties in the town, for Town tax purposes, is \$393,100,868 which equates to a market value of \$2,346,870.854

Regards,  
Todd Wiley

---

**From:** Mark Day [mailto:MDay@madayengineering.com]  
**Sent:** Wednesday, June 20, 2018 1:34 PM  
**To:** jtwiley@town.new-windsor.ny.us

**Cc:** 'Rich Fisher' <rfisher@bantamanagement.com>; 'George Banta' <gbanta@hotmail.com>

**Subject:** Holiday Inn Express - Fiscal Impact Analysis

Mr. Wiley,

It was a pleasure to meet with you the other day. I hope your trip upstate was a good one.

In furtherance of our discussion the other day, I offer the following:

1. I need to know what the assessment would be for the project with construction costs of \$9.2 million. This includes the building, site work, etc. but not furniture or equipment.
2. I need the total number of land parcels in the Town of New Windsor and the total number of non-residential land parcels. As discussed apartment complexes should be seen as commercial properties. The following definitions I hope are helpful.

*Definitions are extremely important in this step. Total local equalized real property value is the aggregate community market value of all local tax-paying properties—residential, farm, vacant, commercial, industrial, etc.—on which taxes are assessed.*

*Nonresidential real property value is the market value solely of commercial and industrial tax-paying properties. Total number of land parcels is the sum of all local properties on which taxes are assessed.*

*Total nonresidential land parcels is the sum of commercial and industrial tax-paying properties.*

3. I also need to know the assessed real property values for all of the parcels in town along with assessed real property values for the non-residential parcels in town as described above.

All of this information is necessary for the “Proportional Valuation Fiscal Impact” method that the Planning Board wants me to use in the Draft Environmental Impact Analysis for the project.

I very much appreciate your help on this. I am trying to wrap the document up and this is the last bit of information I need.

Thank you again,

Mark Day  
M.A. Day Engineering  
845-223-3202

## **E. Consultant's** **Qualifications**

- M.A. Day Engineering Firm Resume
- Marissa Tarallo, PE, PTOE Resume
- Michael Nowicki, B.S. Resume
- Stephen Whalen, R.A. Resume



# M.A. Day Engineering Firm Resume





# M. A. Day Engineering, PC

---

3 Van Wyck Lane  
Suite 2  
Wappingers Falls, New York 12590  
Phone: 845-223-3202  
Fax: 845-223-3206

## Firm Resume

The firm of M.A. Day Engineering, PC, was formed in November of 2001. It was started by its principal, Mark A. Day, PE, after leaving the firm of Day, Oswald and Gillespie to seek his own practice after 10 years of practicing with that firm.

Much of the work done at the firm is related to Structural, Civil and Site Engineering work in the Hudson Valley Area.

The Civil/Site workload consists of residential developments, commercial developments, senior housing projects and affordable housing projects. This work ranges from roadway design, site grading, stormsewer design, sanitary sewer design, water supply design, etc. Much of this work requires interaction with many of the approval agencies such as the Town Planning Boards, NYS and local Board of Health, NYSDOT, NYSDEC and other agencies to obtain the necessary approvals.

The Structural Engineering workload consists of the design of foundation and framing systems for low-rise and mid-rise residential and commercial buildings. The firm conducts numerous structural designs and analyses of new or existing buildings, bridges and other structures. The firm has performed a large amount of work on various projects in the Hudson Valley and in New York City. These projects include:

**Montage at East Fishkill** – 122 lot subdivision in the Town of East Fishkill. This office prepared all of the site and civil drawings and documents and the DEIS for the project.

**Summit Woods subdivision** – 175 lot subdivision in the Town of East Fishkill. This office prepared all of the site and civil drawings and documents and the DEIS for the project.

**Stoneridge Subdivision** – 39 lot residential and commercial subdivision in the Town of East Fishkill. This office prepared all of the site and civil drawings and documents for this subdivision as well as the DEIS.

**LaQuinta Hotel Site Plan** –Hotel and retail building in the Town of Wallkill, New York. This office provided site/civil engineering services for the development of a 4-Story, 87 unit hotel located on a 6.1 acre parcel. The development also included the construction of a 6,000 square foot standalone commercial/retail building. Our services included site plan preparation, grading, stormsewer design, sanitary sewer design, and water supply design.

**Old Hopewell Commons** – Mixed used development located in the Town of Wappinger, New York. This office provided the Site/Civil Engineering for the development of a mixed used development consisting of 45 residential apartment units and 2,000 square feet of commercial

space. Our services included commercial site plan preparation, subdivision layout, site grading, stormsewer design, sanitary sewer design, and water supply design. This project also involved the realignment of an existing town road.

The Engineering Department includes:

**Mark A. Day, PE**, - Graduated from Rochester Institute of Technology in 1986. He is licensed as a Professional Engineer in NY, PA, NJ, MA, and CT. He has worked in the Hudson Valley area since 1982 in the Site/Civil/Structural Engineering field. Mark also has extensive experience in construction and construction management with the NY & NJ Port Authority where he worked as the Resident Engineer on the PATH evacuation shaft projects on Morton Street in New York City and Caisson #1 in Hoboken, New Jersey. These projects had a combined value of approximately \$120 million and lasted approximately 4 years.

**Dennis Lynch, PE** – Dennis graduated of Rochester Institute of Technology’s Civil Engineering program in 2004. Dennis has worked for the firm since 2006. He has extensive experience in material testing and on-site testing. Prior to working for the firm, Dennis worked with Atlantic Testing, a material testing laboratory, in Poughkeepsie, New York. He is proficient at Site Engineering including commercial site plan preparation, subdivision layout, hydrology, stormwater management and stormsewer design.

**Brian Watts** – Brian started with Day Engineering in July of 2014. Brian graduated from Rensselaer Polytechnic Institute with a degree in Civil Engineering in 2011. He is proficient in site engineering including commercial site plan preparation, subdivision layout, hydrology, stormwater management and stormsewer design.

**Anita Odell** – Anita has worked with the firm since its inception and has experience in all facets of the office. She works as a designer/draftsperson between all departments of the firm. Anita’s experience ranges from drafting, minor structural design, and site planning and site layout as well as building planning and layout. She also handles the scheduling of projects with the local Planning Boards. She acted as the liaison between the office and the clients for many of the projects in the office.

**Matt Day** – Matt started working at Day Engineering full time in May of 2016 after graduating from SUNY Polytechnic Institute. He is learning all aspects of site plan preparation, subdivision layouts and stormwater / stormsewer design.

**Kristin Rosborough** – Kristin has been working for the firm since 2007. She works with everyone in the office with drafting and minor structural design tasks. She works with the clients to determine their specific needs for residential and commercial projects.

**Jennifer Maraday** – Jennifer has been working for the firm since 2005. She is the Office Administrator and handles all bookkeeping and human resources for the firm. She is the liaison between clients and the office staff. She handles scheduling and serves as general support for the office.

# Marissa Tarallo, PE, PTOE Resume



# **MARISSA TARALLO, P.E., PTOE**

## **TECHNICAL DIRECTOR**

Marissa Tarallo is a Technical Director at AKRF and is a certified Professional Engineer (P.E.) and Professional Traffic Operations Engineer (PTOE). She has served as project manager for various development projects for both public agencies and private developers including traffic data collection and reduction, capacity analyses, and recommending mitigation measures to improve circulation and traffic flow. She also performs fieldwork, including surveys for on-street and off-street parking utilization, geometric measurements, signal timing and phasing, and traffic flow observations. In addition to her planning experience, Ms. Tarallo specializes in traffic signal design, including preemption, signal interconnect and adaptive signal control systems. Ms. Tarallo has developed numerous microsimulation models for a variety of projects including traffic signal phasing improvements and optimization and is skilled in the use of Highway Capacity Software, Synchro/SimTraffic, VISSIM and AutoCAD.

## **BACKGROUND**

### **Education**

B.S., Civil Engineering, L.C. Smith College of Engineering and Computer Science, Syracuse University, 2011

### **Licenses/Certifications**

Professional Engineer – State of New York

University of California - Berkeley, Institute of Transportation Studies, Technology Transfer Program

Traffic Signal Diagnostics and Maintenance

Traffic Signal Design

Traffic Signal Design: Complete Streets Application

Adaptive Traffic Control Systems

Florida Atlantic University

Adaptive Traffic Control Systems

Professional Traffic Operations Engineer (PTOE)

### **Professional Registrations**

Member, Institute of Transportation Engineers (ITE)

Member, Intelligent Transportation Society of NY (ITS-NY)

Member, American Society of Civil Engineers (ASCE)

## **RELEVANT EXPERIENCE**

### **Route 17 Complete Streets, Sloatsburg, NY**

AKRF was retained by the New York State Department of Transportation, Hudson Valley (NYSDOT) to provide traffic modeling services associated with the complete streets design proposed along a 0.5-mile segment of Route 17 in Sloatsburg. In order to improve traffic operating conditions with reduced roadway capacity, NYSDOT seeks to employ an Adaptive Traffic Control System (ATCS) for the corridor. Ms. Tarallo, serving as project manager, is overseeing the calibration of the existing Synchro/SimTraffic model of the corridor and developing an optimized signal timing plan to be compared with ATCS to determine the benefits of an Adaptive Signal System for the corridor. She is also coordinating with Trafficware to use their virtual traffic controller platform to develop a microsimulation model of the ATCS system. In addition, Ms. Tarallo is working closely with NYSDOT to incorporate the design alternatives and capacity analysis findings into the Design Approval Documents (DAD).



## **MARISSA TARALLO, P.E.**

TECHNICAL DIRECTOR

| p. 2

### **Cortlandt Crossing Traffic Signal Improvements, Town of Cortlandt, NY**

AKRF is providing design and permitting services for traffic signal improvements needed for the construction of the 36-acre Cortlandt Crossing retail development. The retail facility required two new traffic signals along the Route 6 corridor in coordination with the roadway improvements necessary to provide for sufficient traffic flow. In addition, the project included the design and installation of fire preemption devices and an adaptive signal control system for seven traffic signals along approximately 1.6 miles of U.S. Route 6. Ms. Tarallo, serving as project manager, provided preliminary design documents for the proposed traffic signals and preemption devices based on NYSDOT specifications, met and coordinated with NYSDOT, provided response to comments, and prepared the final design documents for construction. In addition, Ms. Tarallo guided key stakeholders through the selection process for an adaptive system which maintained the use of NYSDOT's central management software and provided unique solutions to detection, communication, and pedestrian management constraints. Ms. Tarallo is currently providing construction support services for the traffic signal system including approving shop drawings and coordinating with the contractors.

### **Adelaar Resort (Formerly known as Concord Resort), Thompson, NY**

AKRF prepared an Environmental Impact Statement (EIS) to assess possible impacts from the proposed Adelaar Resort in Thompsonville, NY. The resort would include an 18-hole golf course, a casino and harness racing track, hotels, a residential village with a mix of unit types including condos, apartments, townhouses and detached single family homes, a civic center, a medical home, an active adult residential community, an entertainment district with cinema and supporting retail, an RV park, and a multi-use trail system with abundant open space. Ms. Tarallo performed traffic volume network setup and balancing for existing, future no build, and future build traffic conditions, prepared traffic volume figures, and performed capacity analysis utilizing Synchro and SimTraffic software to determine significant adverse traffic impacts. In addition, Ms. Tarallo served as project manager for the design and construction support of the traffic signals for the project's main entrance and at the interchange leading to the project site. Ms. Tarallo coordinated with town, county and NYSDOT officials to assure the signal design met the operational and construction requirements of the various stakeholders.

### **Mercy College Traffic Signal Design, Dobbs Ferry, NY**

AKRF was retained to develop the traffic signal improvements needed to complete the Mercy College Dormitory and to gain necessary approvals from NYSDOT with coordination from both the Village of Dobbs Ferry and Irvington. Ms. Tarallo served as project manager for the design of the new traffic signal including removal of the existing infrastructure, updating of the system for improved safety and operations, and quantifying new equipment for installation compliant with NYSDOT standards and specifications. Ms. Tarallo prepared the final design plans, encompassing both civil engineering and traffic engineering principles, to be issued for construction.

### **Putnam County Commercial Corridors Feasibility Study, Putnam County, NY**

AKRF was retained by the Putnam County to prepare a Commercial Corridors Feasibility Study with a Recommended Plan of Action including a market study and an evaluation of various commercial revitalization strategies, as well as a needs assessment of roadways and transportation conditions for nine commercial corridors throughout the County. AKRF is preparing the needs assessment of roadways and transportation elements for the nine commercial corridors in the county. Ms. Tarallo, serving as deputy project manager, is responsible for project schedule, budget and documentation. She is currently leading the data collection effort and transportation assessment of the nine corridors and will be leading the development of mobility and parking management strategies for each of the corridors.

### **Town of Cortlandt, Clarkstown, and Hyde Park Traffic Consultant, NY**

As the Town Traffic Consultant, AKRF's responsibilities include reviewing site plans and environmental assessments from a traffic standpoint to ensure that capacity analyses, parking, site access and egress, and internal site circulation issues are adequately and correctly addressed in reports that are submitted to the Town. Ms. Tarallo,



## **MARISSA TARALLO, P.E.**

**TECHNICAL DIRECTOR**

| p. 3

-serving as project manager, has led the review of a wide variety of Traffic Impact Studies, ranging from due diligence studies to large-scale EIS reviews involving vehicular, pedestrian, bicycle and safety concerns. In addition, Ms. Tarallo has led several standalone projects including parking, warrant, and complete streets studies. Her responsibilities include managing the scope, budget, and documentation for each individual project, regardless of size, and close coordination with the Town. Ms. Tarallo has also presented findings to the Town Planning Boards.

### **Cortlandt Medical Oriented District (MOD), Town of Cortlandt, NY**

AKRF was retained by the Town of Cortlandt to prepare a Due Diligence Traffic Study associated with the proposed Cortlandt Medical Oriented District (MOD) along the Route 202/35 corridor. AKRF performed trip generation surveys and estimated the levels of traffic associated with the proposed development plan which were added to existing traffic levels to determine anticipated impacts. The AKRF team then developed improvement measures for the corridor including geometric improvements. Ms. Tarallo, serving as deputy project manager, oversaw the trip generation and traffic analysis development. She developed recommendations for improvements to the corridor including geometric improvements, such as roadway restriping and widening, and signal improvements, including preparation of signal warrants for the installation of new traffic signals, and provided an engineering cost estimate for the proposed improvements. In addition, Ms. Tarallo met and coordinated with potential developers, Town and NYSDOT officials in order to build consensus for the proposed improvements.

### **New Rochelle Microsimulation, New Rochelle, NY**

AKRF was retained by the City of New Rochelle to identify and test opportunities and recommendations to improve circulation in various locations throughout the City. This included improving vehicular and pedestrian circulation near the New Rochelle Train, the conversion of street directions (one-way streets to two-way streets and vice versa), implementing turn restriction, creating pedestrian plazas, widening sidewalks, and providing a pedestrian crossing over I-95 via a pedestrian bridge. Ms. Tarallo prepared microsimulation models of corridors in the study area utilizing Synchro and SimTraffic software. She developed and calibrated/validated the existing models based on field observations and data collection and developed future volumes for proposed circulation changes. Ms. Tarallo also assisted in the preparation of technical memorandums outlining results of various stages of the project, and assessing the feasibility of the proposed circulation changes.

### **French American School of New York, White Plains, NY**

AKRF prepared an Environmental Impact Statement (EIS) to assess possible impacts from the proposed campus of the French American School of New York. Ms. Tarallo performed traffic volume network setup and balancing for existing, future no build, and future build traffic conditions, prepare traffic volume figures, develop trip generation estimates for the proposed project, and perform capacity analysis utilizing Synchro software to determine significant adverse traffic impacts. In addition, Ms. Tarallo assisted in analyzing the site access and on-site circulation using the VISSIM simulation software to determine the most viable option for school drop-of and pick up locations.

### **Governors Island EIS, Manhattan and Brooklyn, NY**

AKRF prepared an Environmental Impact Statement (EIS) to assess possible impacts from the proposed improvements to Governors Island. Ms. Tarallo performed the level 2 pedestrian trip generation analysis, existing, no build, and future with project conditions, and performed pedestrian capacity analysis. She also assisted with traffic volume network setup and performing traffic capacity analysis utilizing HCS2000 software to determine significant adverse traffic impacts. In addition, Ms. Tarallo assisted in developing conceptual mitigation measures and determining the feasibility of such measures based on existing site conditions utilizing AutoCAD software.

### **Kingsbridge Armory EIS, Bronx, NY**

AKRF prepared an EIS for redevelopment of the Kingsbridge Armory, an historic landmark, with approximately 605,370 square feet of new uses and approximately 400 parking spaces. The proposed project would redevelop the



## **MARISSA TARALLO, P.E.**

**TECHNICAL DIRECTOR**

| p. 4

Kingsbridge Armory with entertainment uses, community facilities, a fitness club, and retail and restaurant space. Ms. Tarallo assisted in coordinating the transportation related analysis efforts for the Draft and Final EIS including preparing the traffic capacity analysis utilizing HCS2000 software to determine significant adverse traffic impacted and transportation related chapters. She also assisted in developing traffic mitigation measures utilizing Synchro and AutoCAD software. In addition, Ms. Tarallo actively participated in agency review meetings and prepared responses to comments.

### **New York City Department of Environmental Protection – Delaware Aqueduct Rondout, Thompson, NY**

AKRF prepared an Environmental Impact Statement (EIS) for the proposed development of a bypass tunnel to address the known leaks in the Rondout-West Branch Tunnel. Ms. Tarallo performed traffic volume network setup and balancing for existing, future no build, and future build traffic conditions, prepared traffic volume figures, and performed capacity analysis utilizing Synchro software for two large study areas in Dutchess and Orange Counties.



# Michael Nowicki, B.S. Resume



### ECOLOGICAL SOLUTIONS

*Ecological Solutions* was started to provide a wide range of natural resource management services to private clients, non-profit organizations, and municipalities. The professional staff of *Ecological Solutions* has over 30 years of experience in wetland and natural resource investigations, permitting, monitoring, and environmental site assessments and planning. We are dedicated to helping our clients achieve their development goals while conserving and enhancing the existing on-site natural resources. Services include guiding our clients through the changing Federal, State, and Local permitting processes.

### EDUCATION

*State University of New York-College of Environmental Science and Forestry:*  
B.S. Environmental and Forest Biology, May 1988.

*Rutgers University:* Hydric Soils 1993, Endangered and Threatened Species 1999.

### PROFESSIONAL EXPERIENCE

**WETLANDS/NATURAL RESOURCES:** Mr. Nowicki has over 30 years of experience in natural resources management and providing the following services. Wetland Services: wetland delineations, functional evaluations, Federal, State, and Local Permitting, mitigation, and mitigation monitoring.

Natural Resource Management Services: floral, faunal, and threatened/endangered species surveys including: New York State endangered and threatened plants, Blanding's Turtle, Bog Turtle, Karner Blue Butterfly, Timber Rattlesnake, Indiana Bat, Northern Cricket Frog, and Eastern Tiger Salamander; vegetative cover type description and mapping; pre-development site review; pond and habitat restoration and creation.

Forest and Woodland Management Services: forest tree survey and inventory; forest management plans for economic returns, aesthetic, and safety considerations, and habitat for specific wildlife species;

**WILDLIFE ECOLOGY:** Mr. Nowicki has 30 years of experience with wildlife ecology field research. He has worked on large projects that include wolf, grizzly bear, and white-tailed deer studies, and raptor surveys.

**PLANNING:** Mr. Nowicki serves as a project manager and drafts Environmental Impact Statements; implements SEQRA; drafts zoning ordinances, including aquifer and ridgeline protection; makes presentations to Village and Town planning and zoning boards, and reviews projects on behalf of private clients and municipalities.

**ENVIRONMENTAL SITE ASSESSMENT:** Complete Phase 1 environmental site assessments in accordance with ASTM E 1527-13 and the Final Rule in conformance with 40 CFR Part 312.



# Stephen Whalen, R.A. Resume



# STEPHEN A. WHALEN, R.A., LEED A.P.

3 Van Wyck Lane, Suite 1  
Wappingers Falls, NY 12590

Phone (845) 227-9190  
email: sw@whalenarchitecture.com

## EDUCATION:

New York Institute of Technology  
Date of Graduation: May 21, 1994  
Degree: **Bachelor of Architecture**

## EXPERIENCE:

**WHALEN ARCHITECTURE, PLLC** – Wappingers Falls, NY – *President*

*April 2012 – May 2014*

- New York State Registered Architect since August 2004
- Currently establishing residential and commercial client base
- Meets with potential clients to discuss new project's design, program, and requirements
- Provides schematic and design development drawings on architectural projects
- Performs field measurements at client's building to determine existing layout and conditions
- Researches products for architectural applications and specifications
- Researches LEED/ green building products for residential and commercial projects
- Drafts finished working drawings of residential, commercial, healthcare, and municipal projects
- Prepares project specifications for commercial projects
- Coordinates operations with consulting engineers
- Reviews shop drawings on commercial projects
- Provides field construction administration on projects
- Provides structural analysis on residential projects
- Whalen Architecture's staff includes two project managers and an office manager.

*May 2016 - Present*

**HIGHLANDS ARCHITECTURE, PLLC** – Cold Spring, NY – *Partner*

*May 2014 – May 2016*

**THE SWARTZ ARCHITECTURAL GROUP** – Poughkeepsie, NY – *Project Manager*  
(formerly CERNIGLIA & SWARTZ ARCHITECTS) – *Partner*

*June 2002 to Aug 2005*

*Aug 2005 to April 2012*

**THE HELMES GROUP**, Katonah, NY – *Project Manager*

*June 2000 to June 2002*

**DENNIS NOSKIN ARCHITECTS**, Valhalla, NY – *Project Manager*

*June 1999 to June 2000*

**TAYLOR ASSOCIATES**, White Plains, NY – *Project Manager*

*June 1997 to July 1999*

**INTERIOR CONCEPTS BY DESIGN**, Valley Stream, N.Y. – *Project Manager*

*May 1996 to June 1997*

**STANLEY C. GRANT**, New York, N.Y. - *Draftsperson*

*Nov 1994- May 1996*

**DESIGN CLASSICS ARCHITECTS**, Dix Hills, N.Y. – *Draftsperson*

*Nov 1993- Nov. 1994*

## SOFTWARE SKILLS

- AutoCAD 2017, Revit Architecture 2017, SketchUp, Adobe Photoshop
- REScheck, COMcheck
- Windows 10, Microsoft Office

## PERSONAL

- Non-credit Instructor for Revit at Dutchess Community College
- LEED AP as of June 2009
- Member of Dutchess County Regional Chamber of Commerce
- Member of Professional Networking Powerhouse
- Certified ICC Residential Energy Plans Examiner
- Member of New Hackensack Reformed Church
- Currently residing in Wappingers Falls since August 2000
- References available upon request

